

Injection Septum Pre-CDR

Dr. Petr Shatunov

Budker Institute of Nuclear Physics, Novosibirsk, Russia

**Novosibirsk
28, November, 2019**



Beams Injection

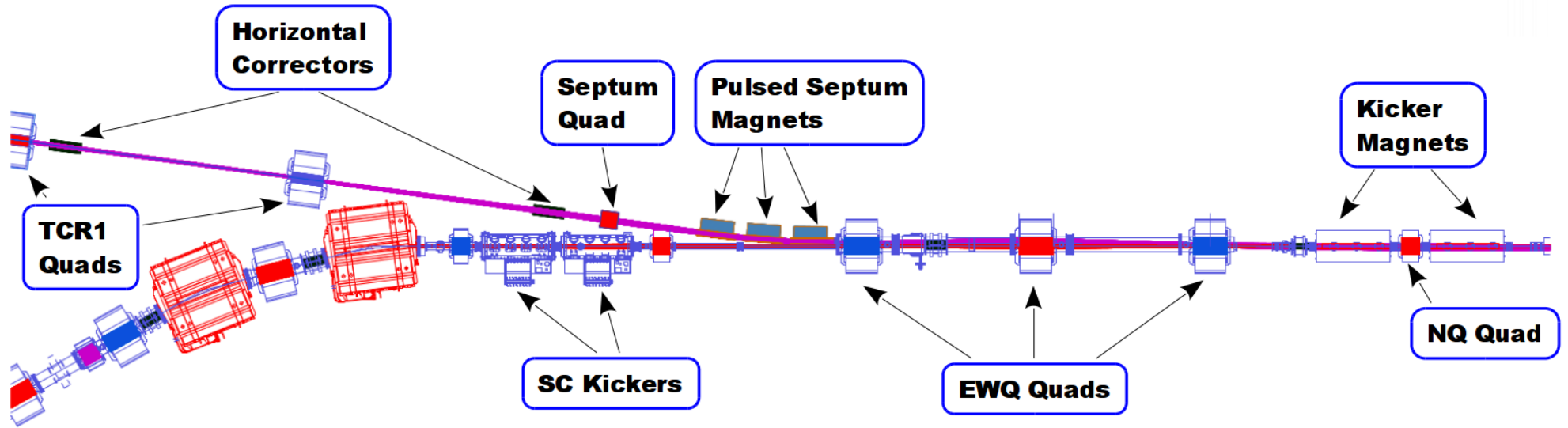

Aperture limitations for injected beam

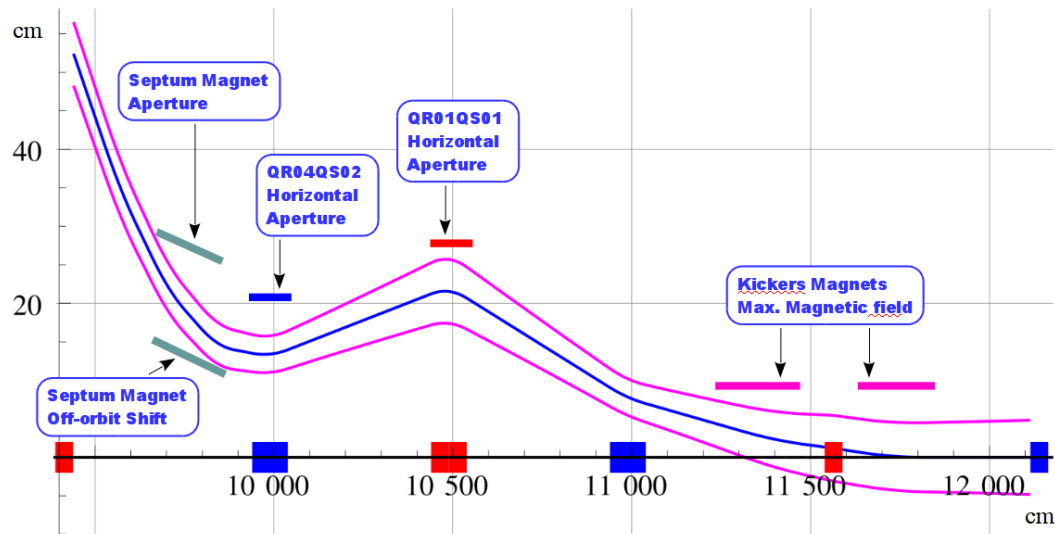

Beam cross-sections @ septa

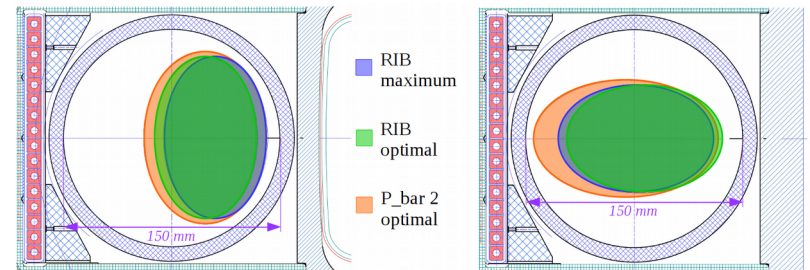

Injection Septum Magnet

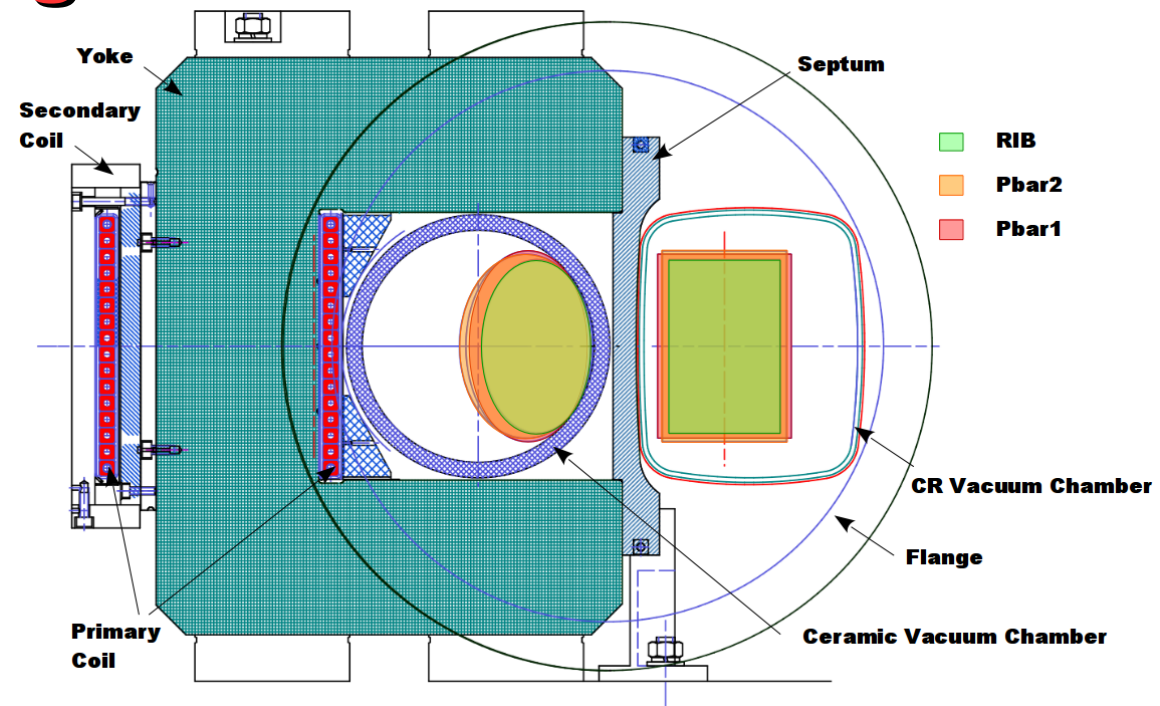

Maximum magnetic field in the aperture	0.6 T
Minimum magnetic field in the aperture	0.3 T
Pole gap height	173 mm
Air gap width	180 ÷ 200 mm
Flux density in yoke	1.2 ÷ 1.5 T
Relative integral magnetic field quality in the vacuum chamber	10^{-3}
Effective magnetic length	0.952 m
Yoke length	≤ 0.952 m
Yoke width	≤ 0.420 m
Yoke height	≤ 0.420 m
Assembled magnet mass	≤ 1.0 t
Orbit radius	21.666 m
Maximum deflection angle	0.04233 rad
Field rise time (0 to max)	0.75ms
Lamination thickness	1.0 mm
Packing factor	0.98

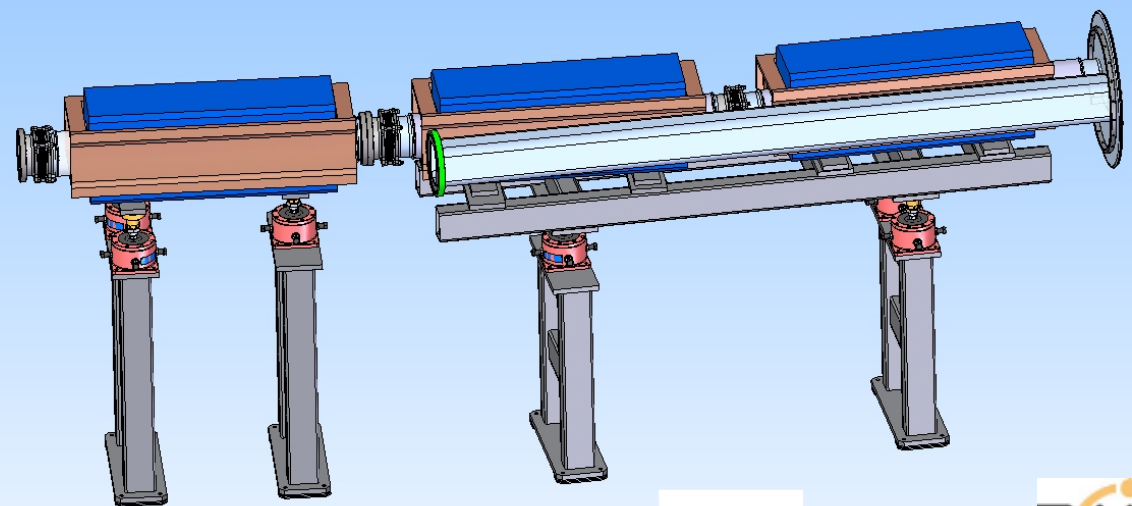

2018



Injection Septum Magnet Simulations

8/Nov/2018 00:07:26

Map contours: BY
-7.003086E-03

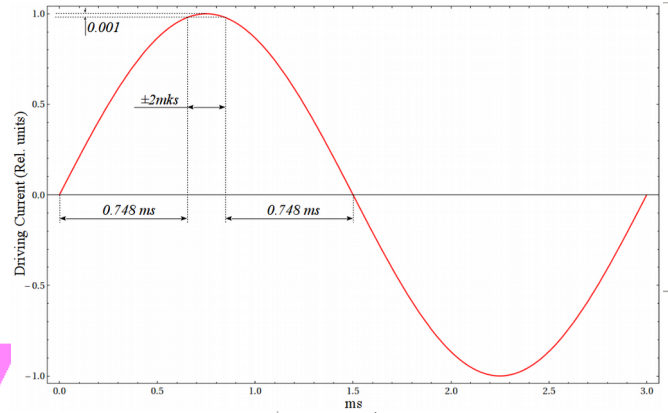
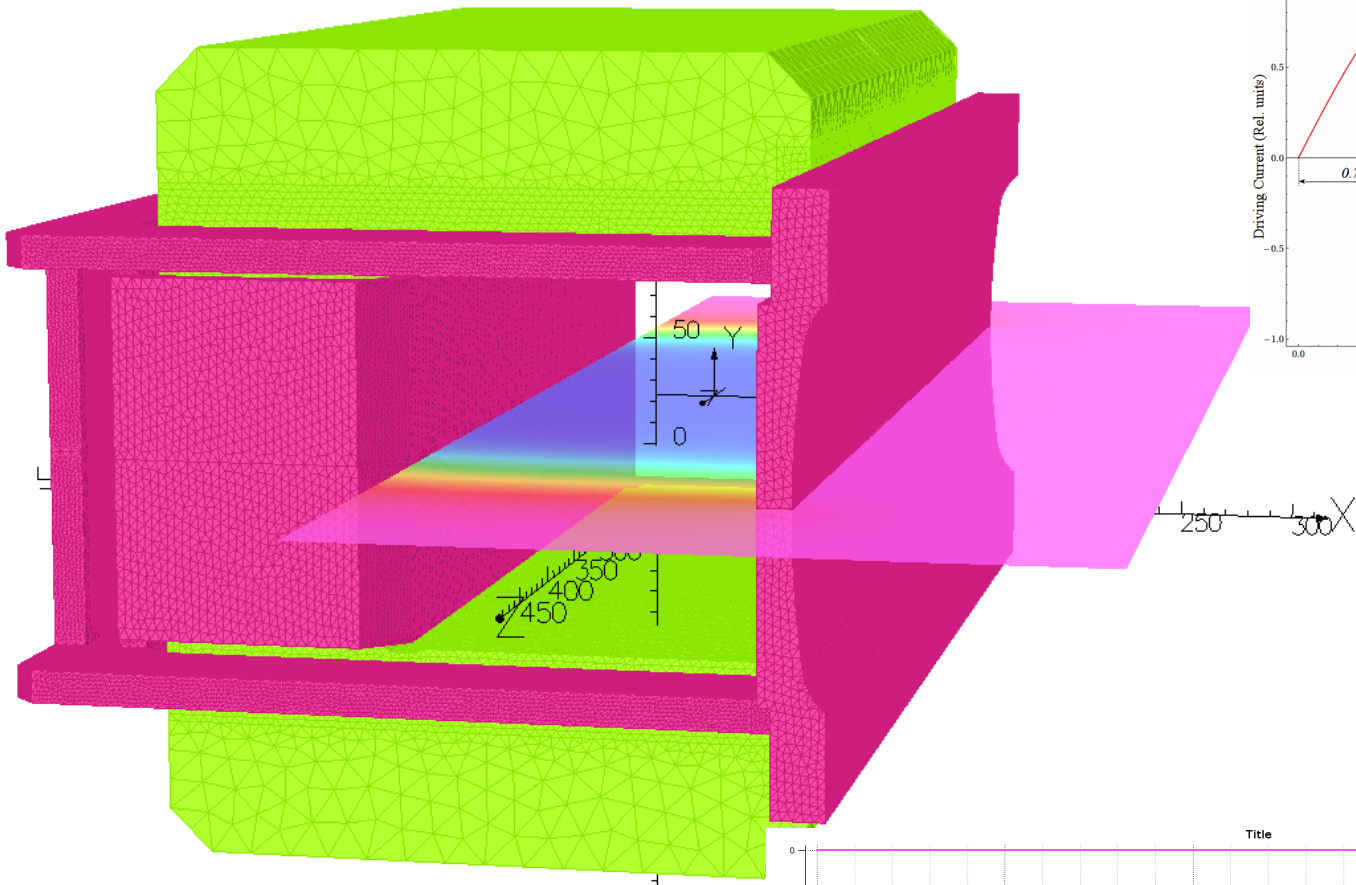
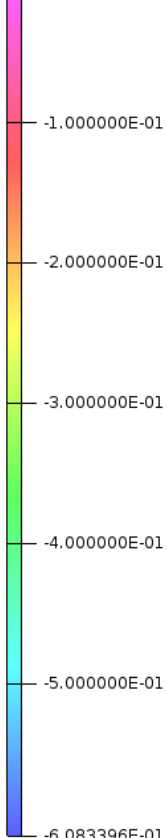

3731068 elements
4614351 edges
Nodally interpolated fields
Activated in global coordinates
Reflection in XY plane (Z field=0)
Reflection in ZX plane (Z+X fields=0)

Field Point Local Coordinates
Local = Global

FIELD EVALUATIONS

Line	LINE (nodal)	151	Cartesian
	x=-80.0 to	y=0.0	z=0.0
		70.0	
Cartesian	CARTESIAN	100x100	Cartesian
	(nodal)		
	x=-90.0 to	y=0.0	z=-470.0 to
	250.0		470.0

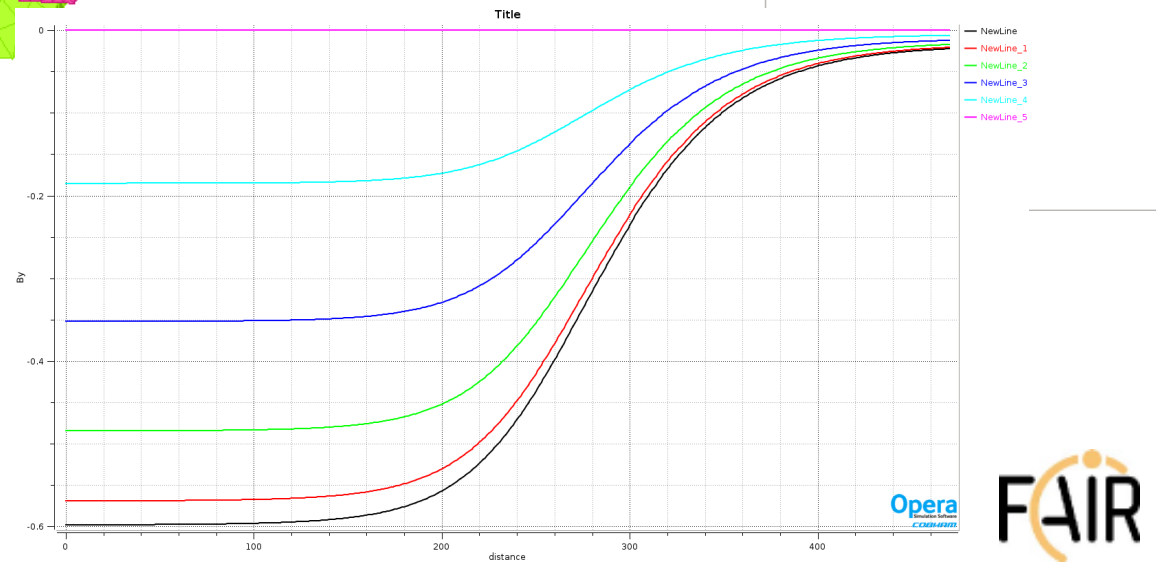
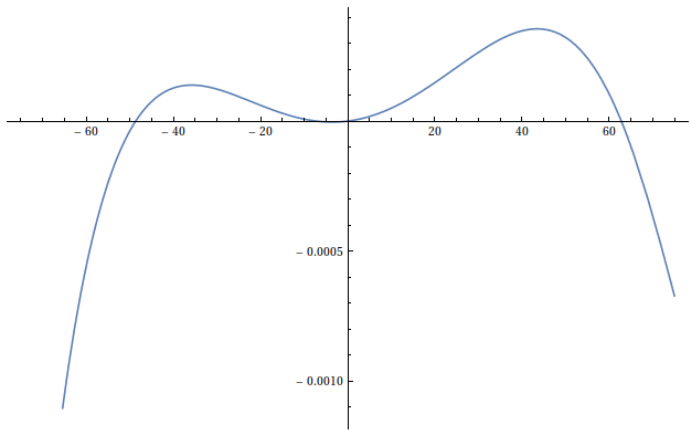

Injection Septum Full 3D Model

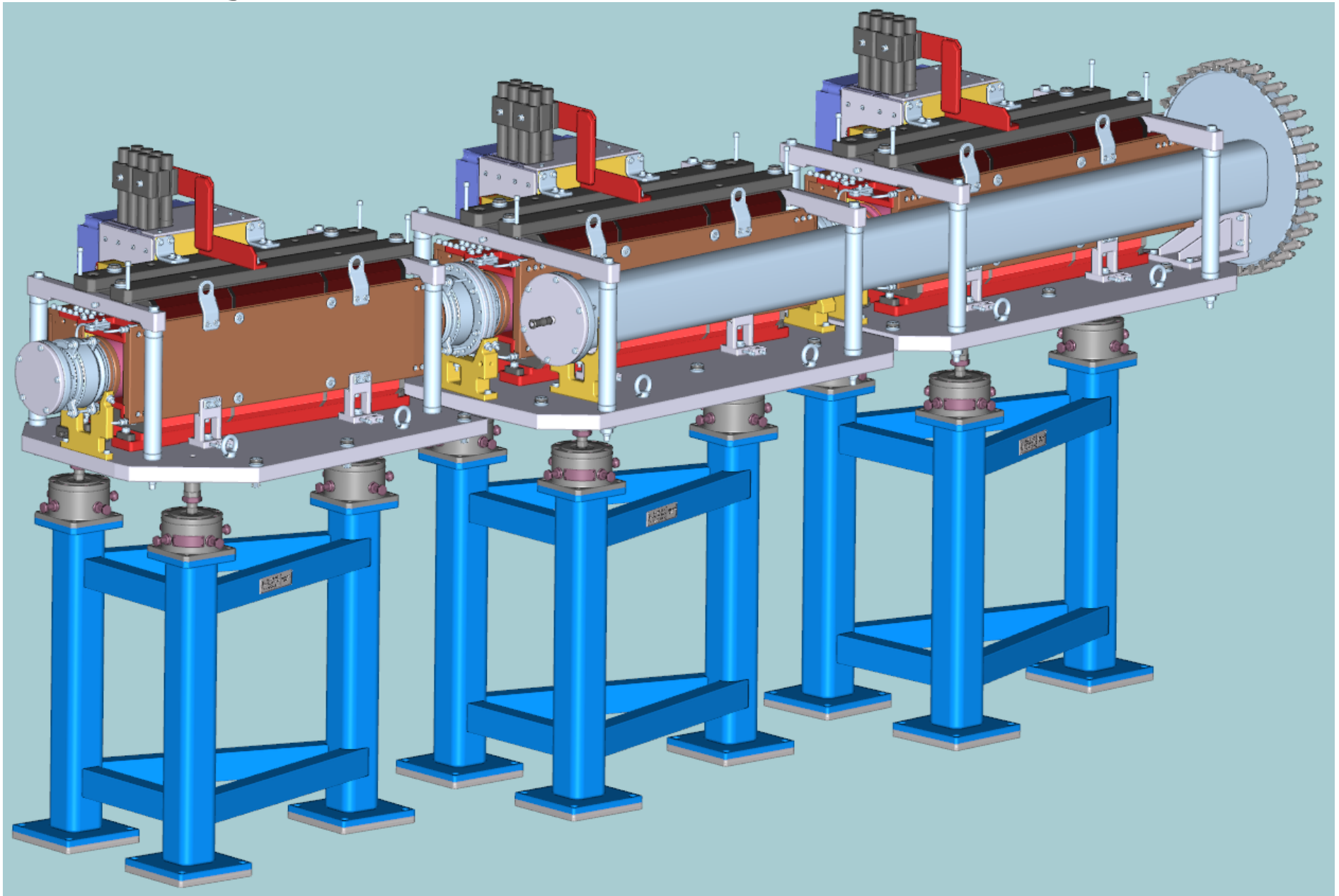

View from inside of CR

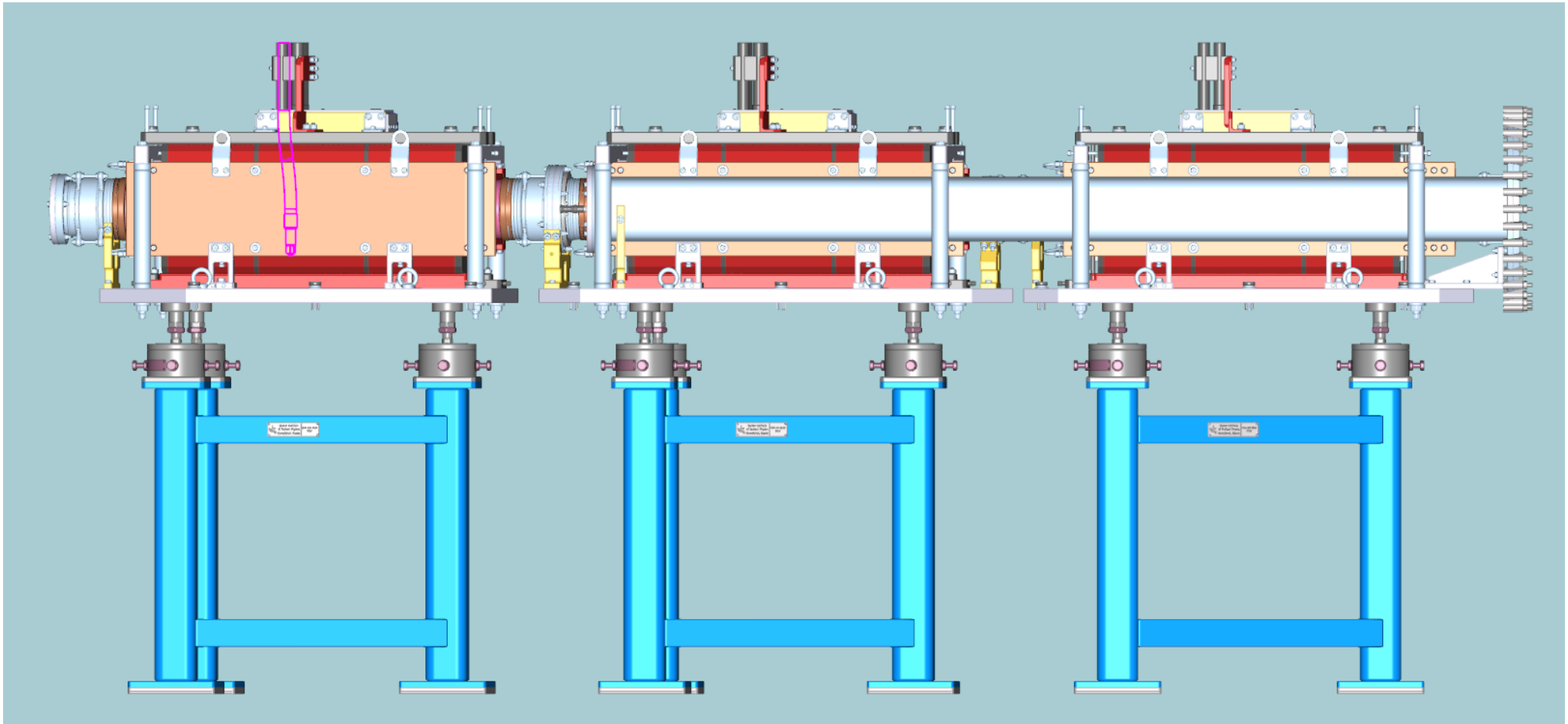

View from outside of CR

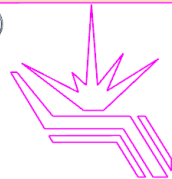
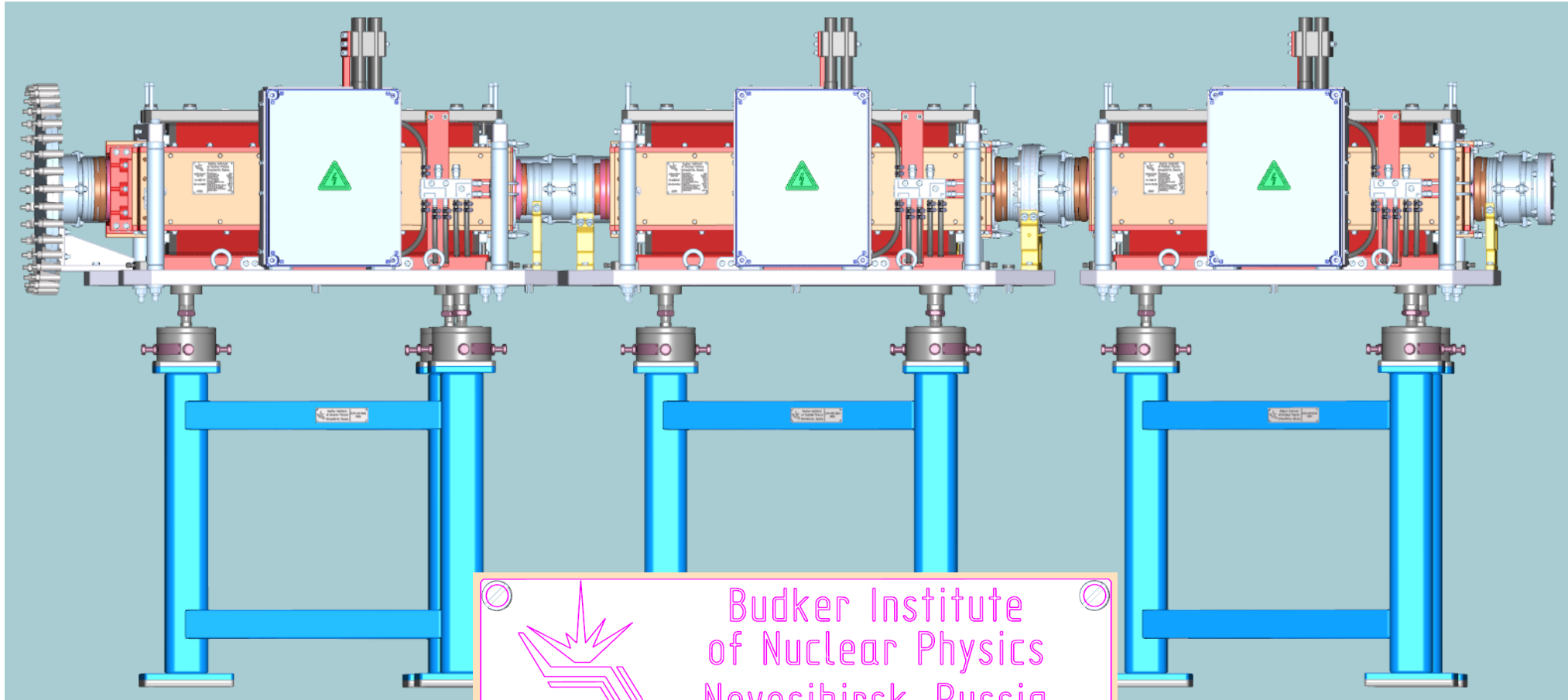

Budker Institute
of Nuclear Physics
Novosibirsk, Russia

SEPTUM MAGNET
CR04MP11

XX-0000-XX

FCRM ISM 050000

2020

FLUX DENSITY	0.6 T
DEFLECTION ANGLE	2.465619°
BENDING RADIUS	21.666 m
NOMINAL CURRENT	5.16 kA
NOMINAL VOLTAGE	3.5 kV
ENERGY LOSSES PER CYCLE	631 J
INDUCTANCE	0.32 mH
COOLING WATER REQUIREMENT	1 l/min
DIFFERENCE OF PRESSURE	1 bar
DIFFERENCE OF TEMPERATURE	2 °C
TOTAL WEIGHT	997 kg



Assembling: Supports

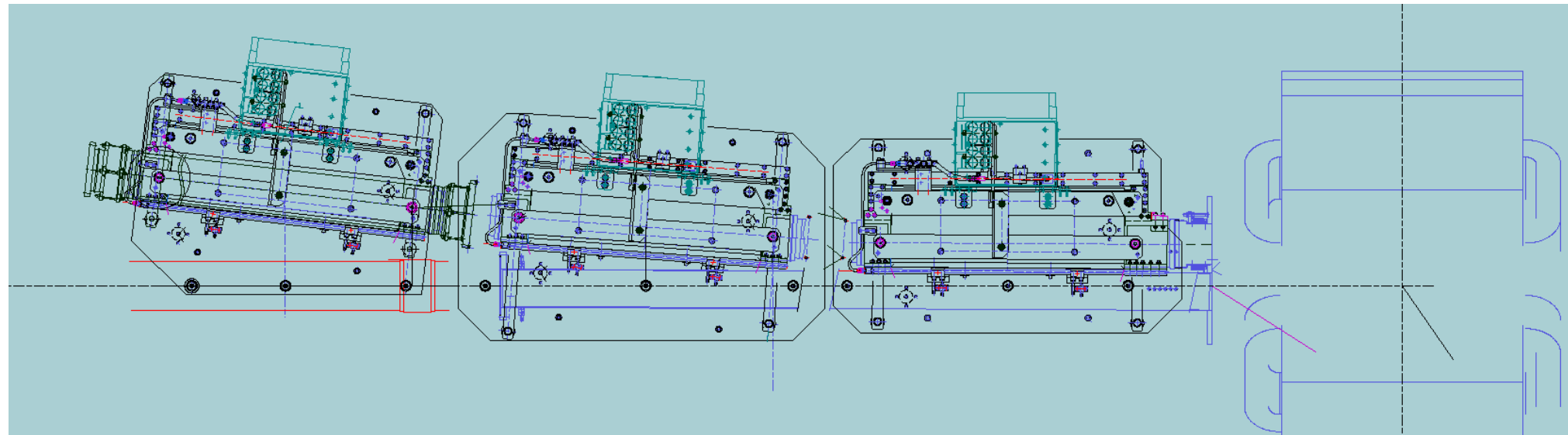
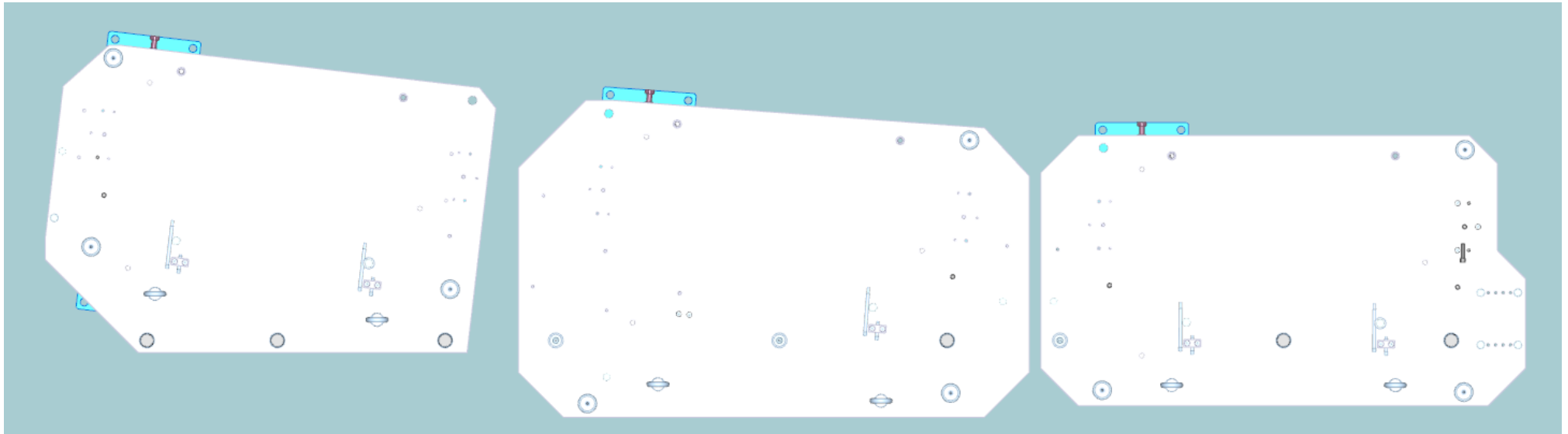

Assembling: Bottom yoke part

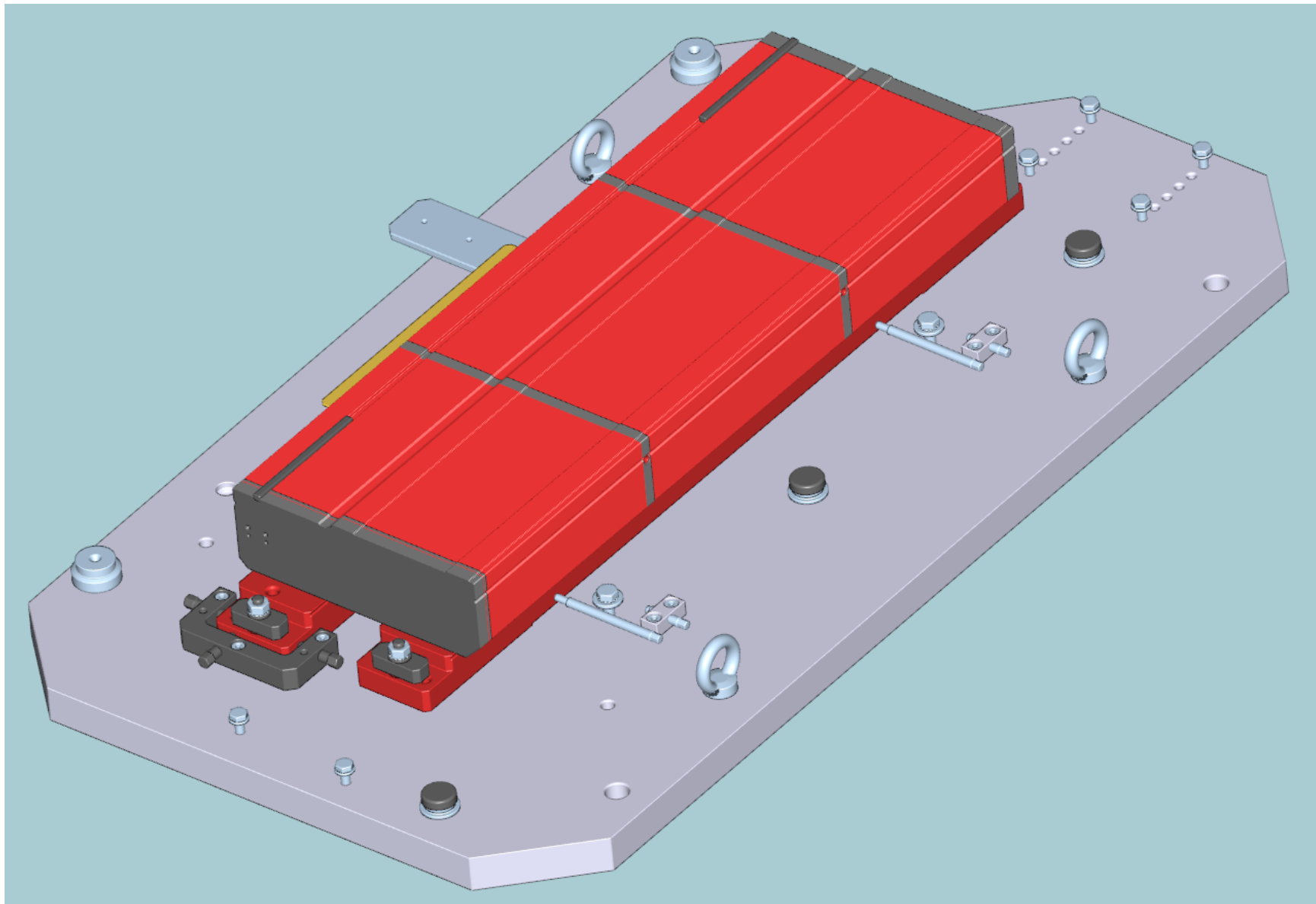

Assembling: Middle Yoke part + Primary Coil

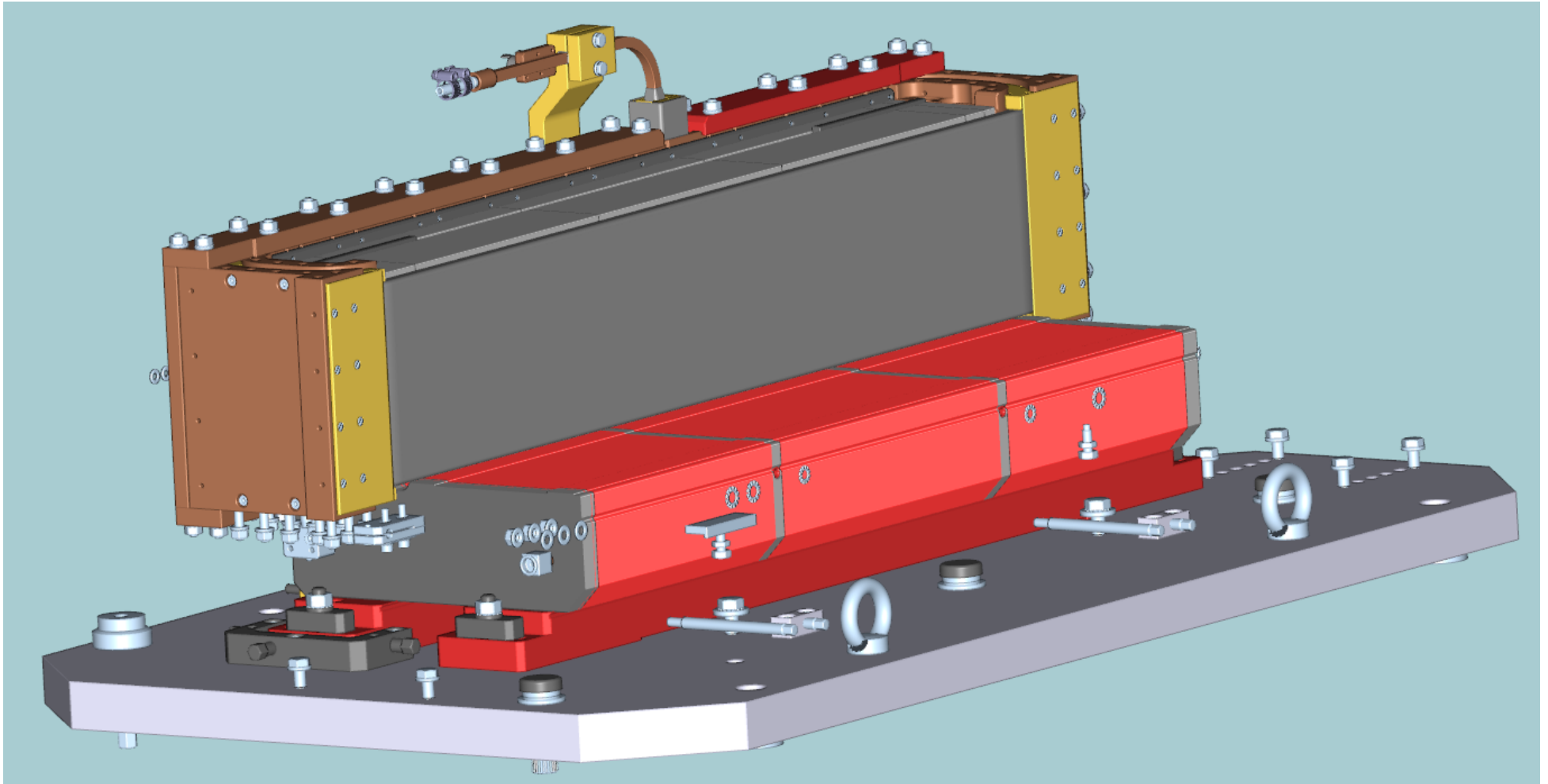

Middle Yoke part + Primary Coil

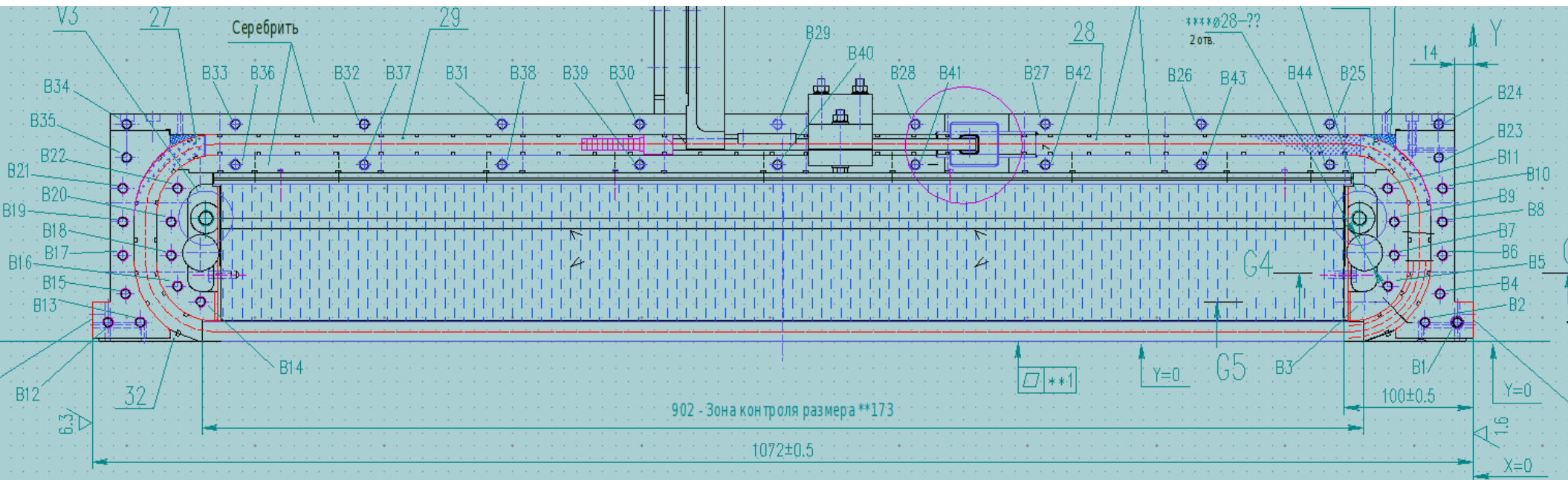
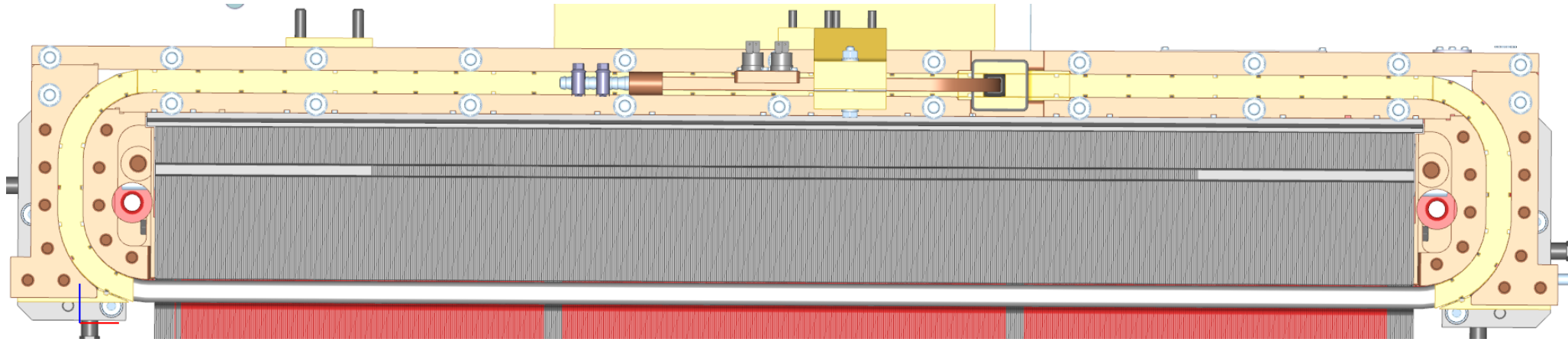

Assembling: Top Yoke part

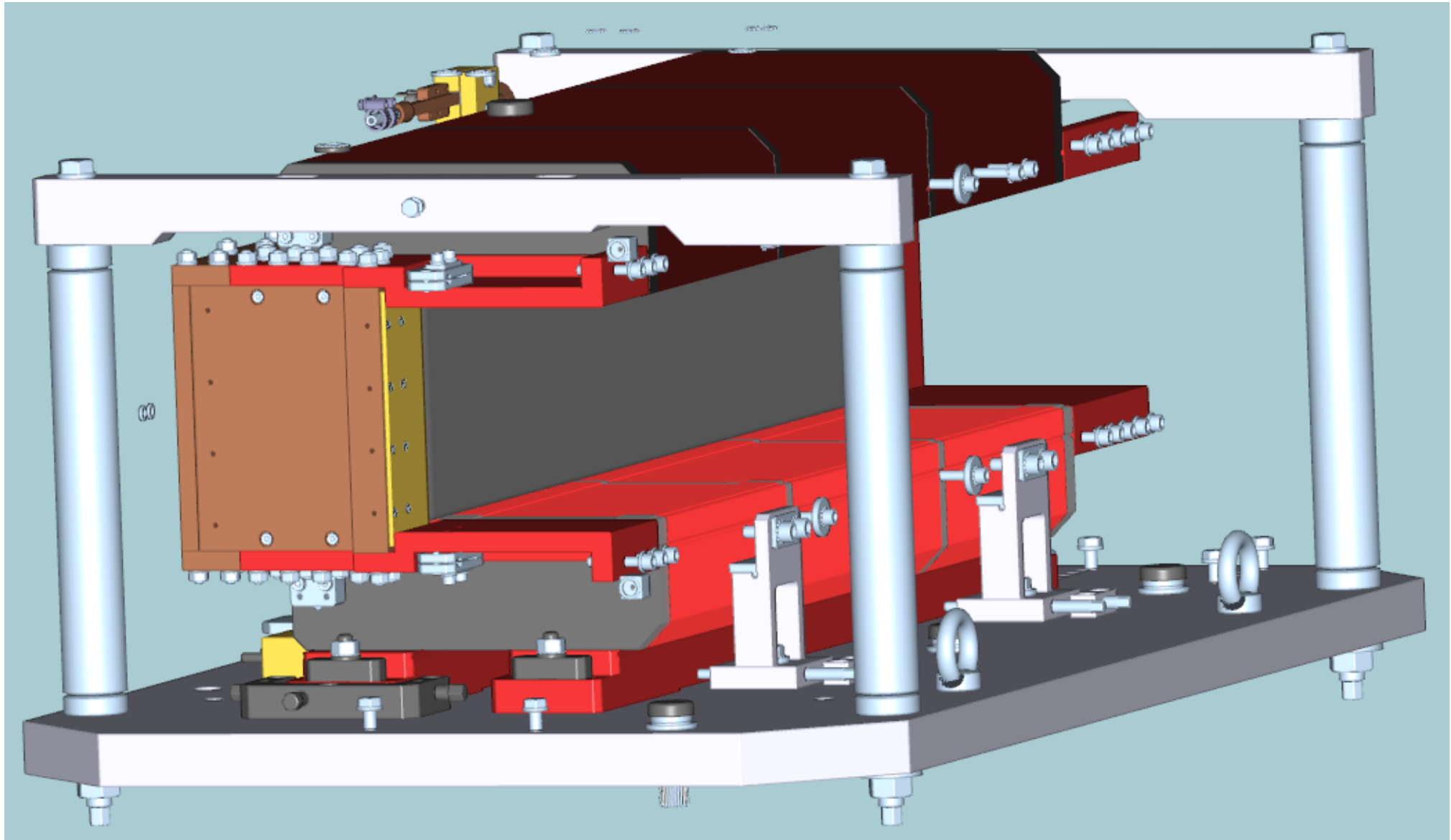

Assembling: Septum Electrode

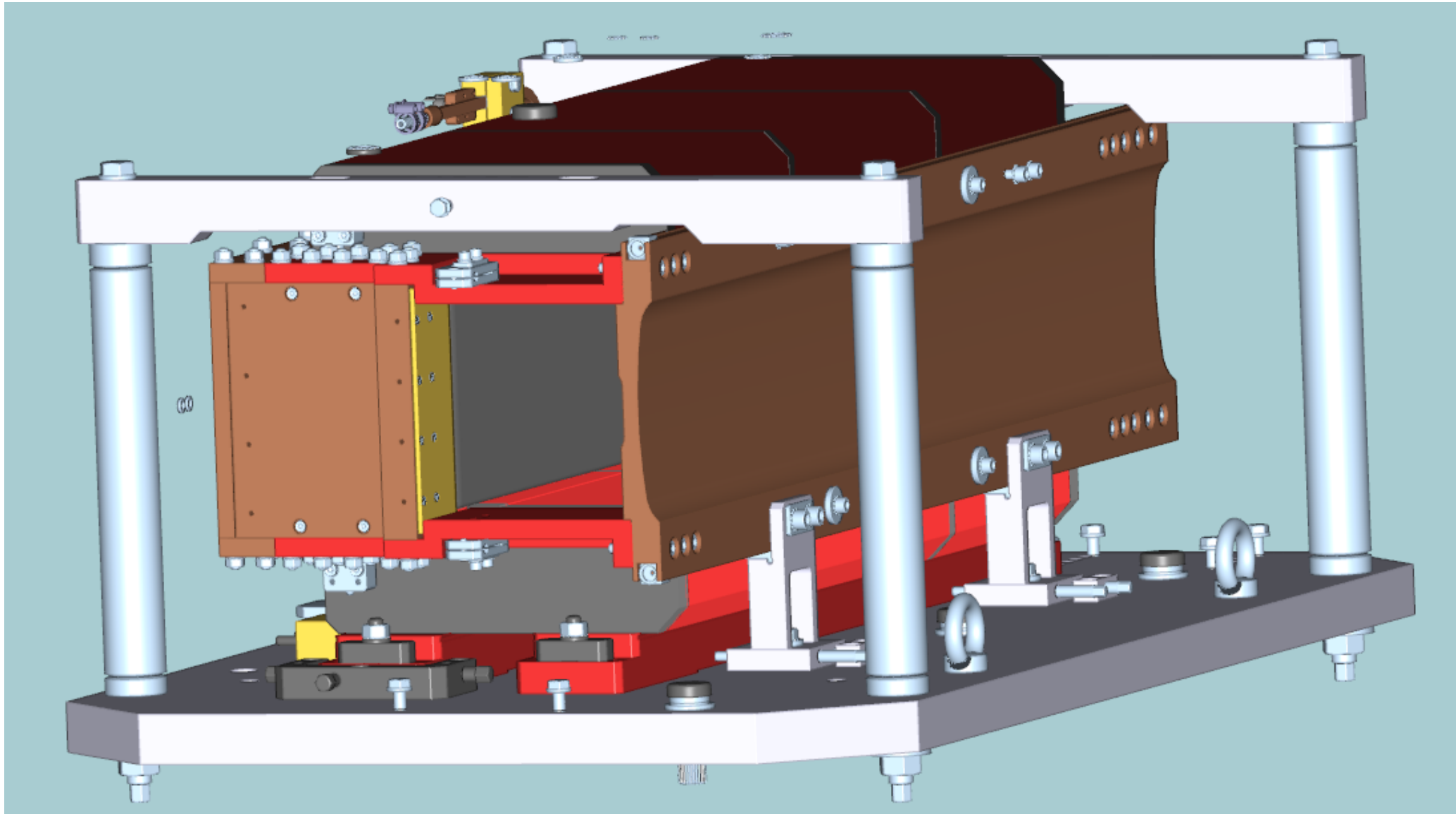

Assembling: Yoke is finished

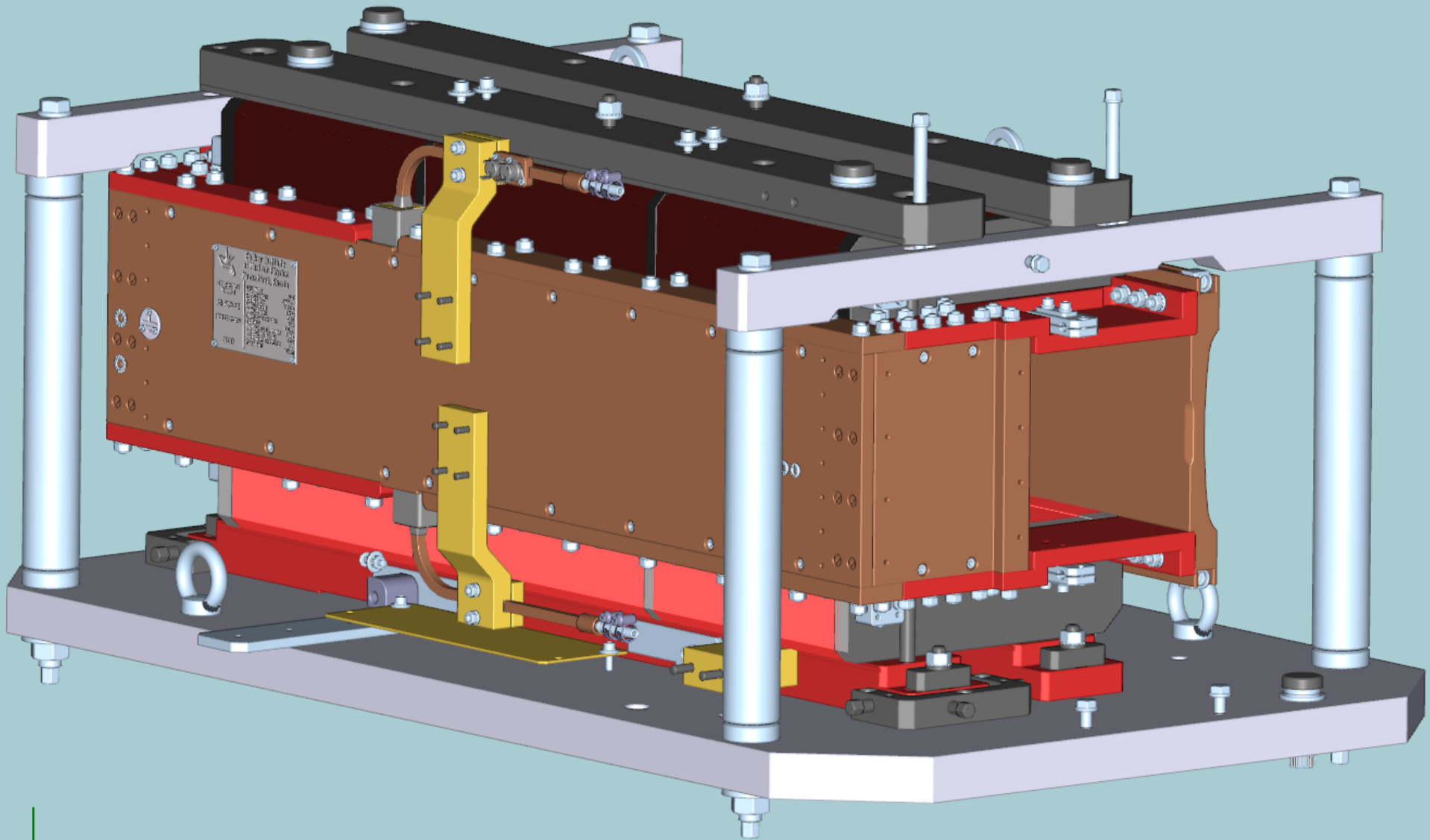

Assembling: Connection box

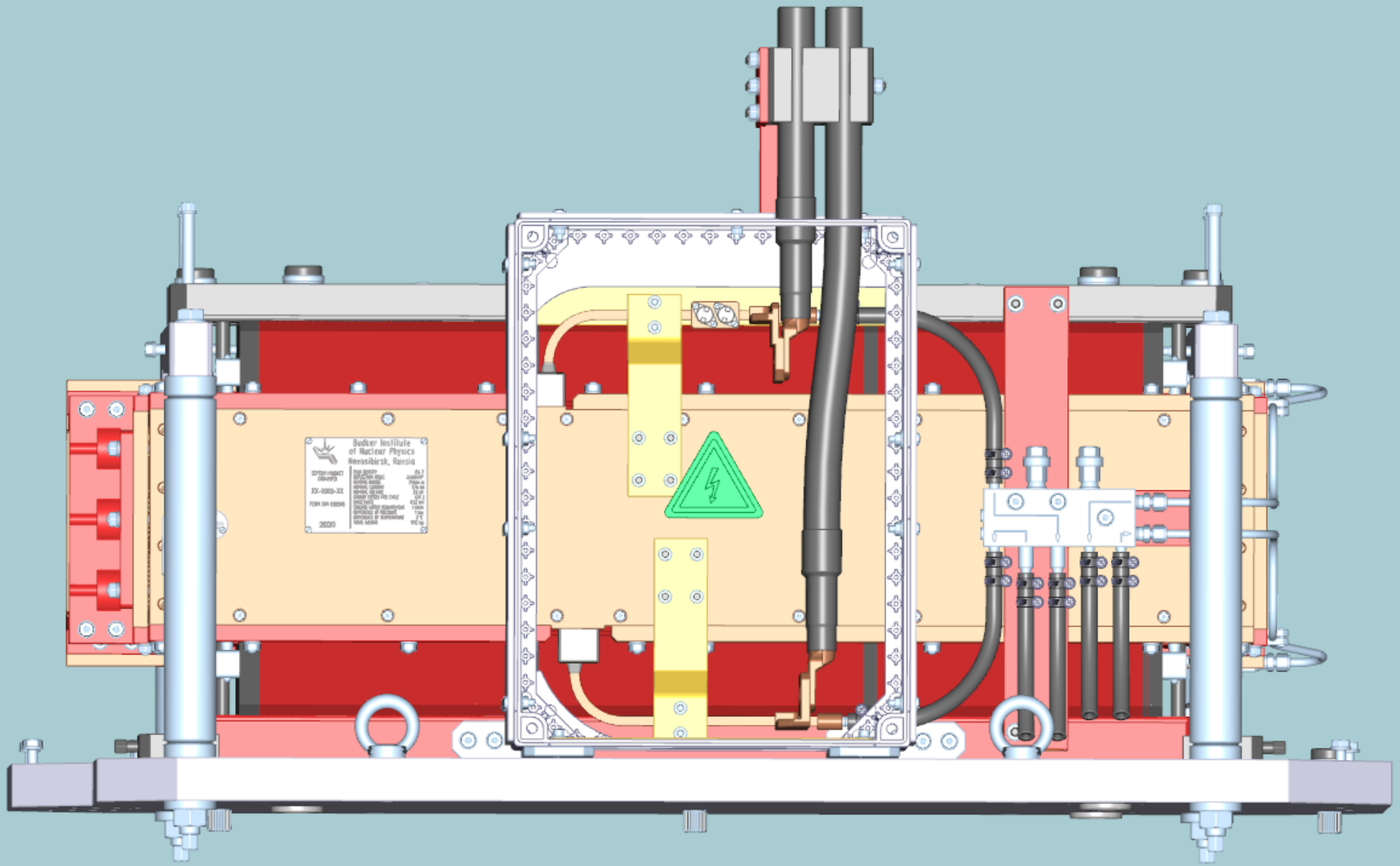

Vacuum chamber

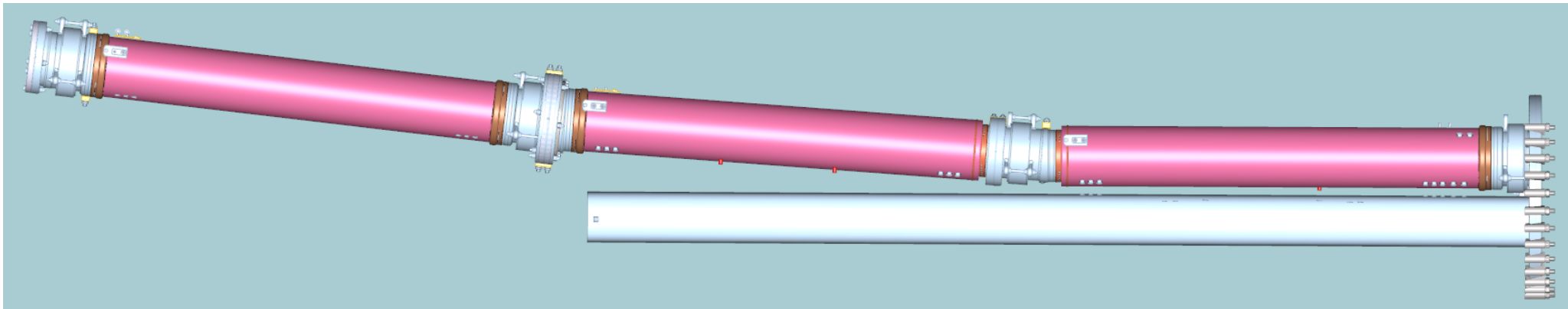
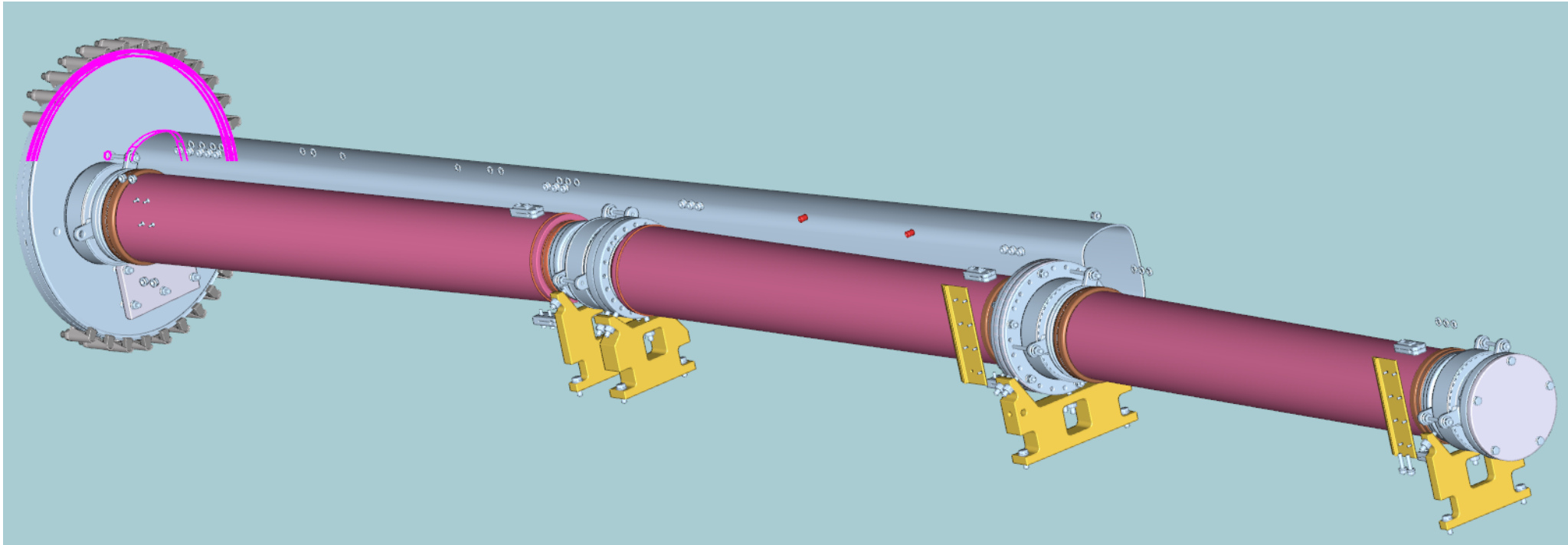

Vacuum chamber

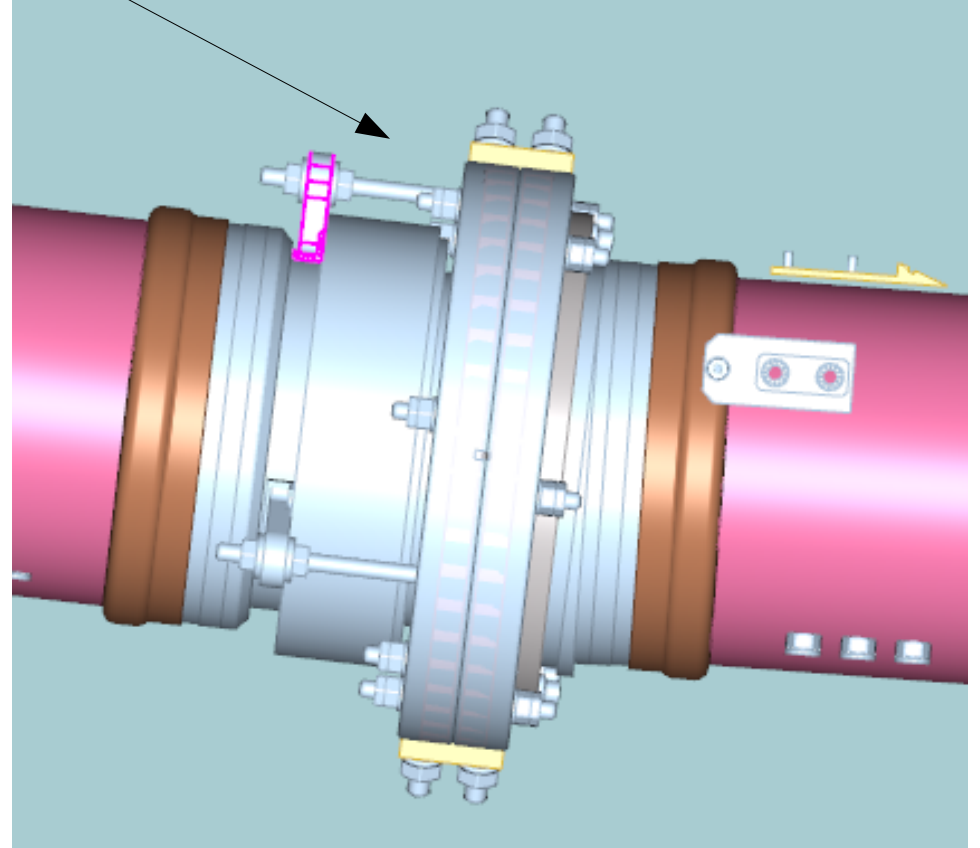
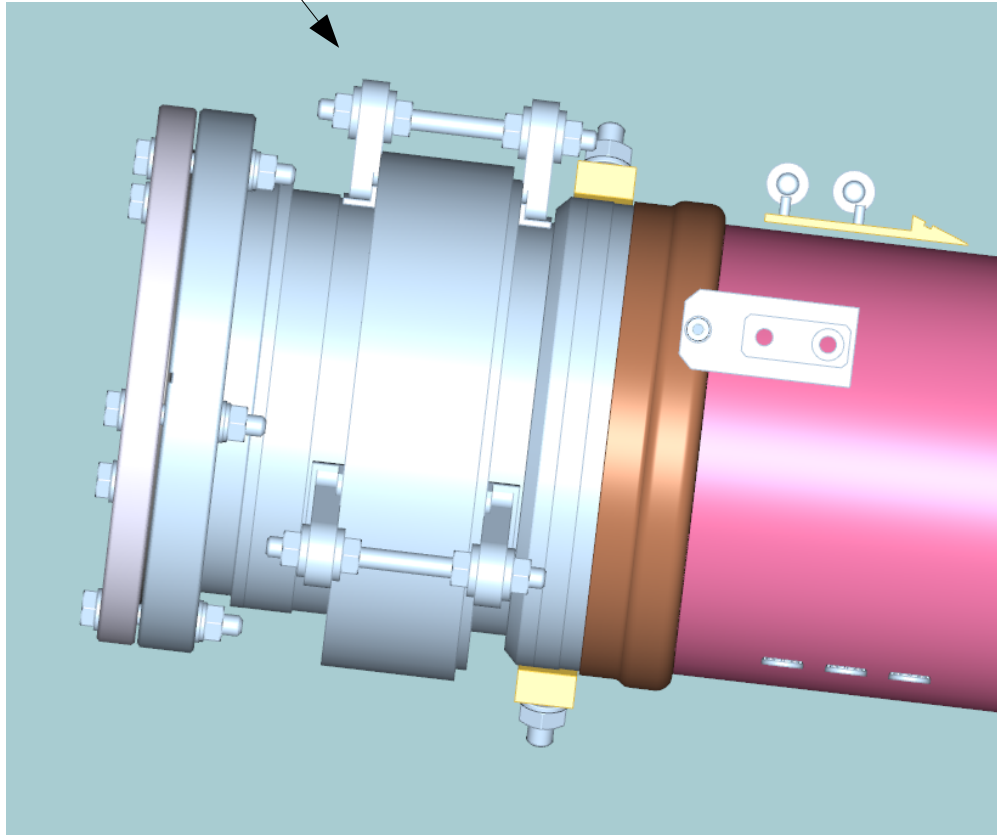
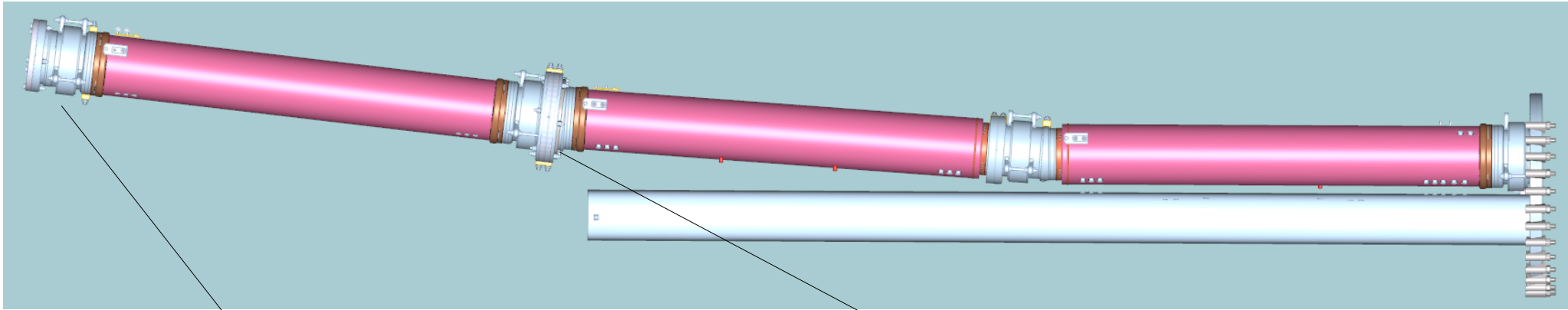

Vacuum chamber

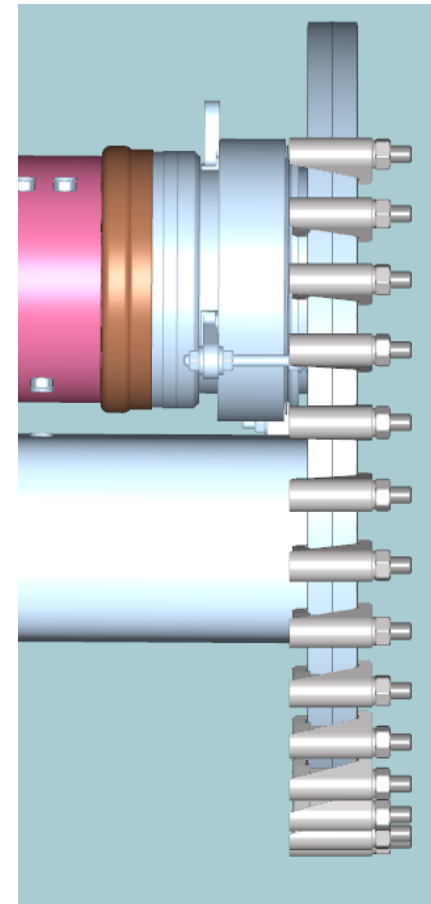
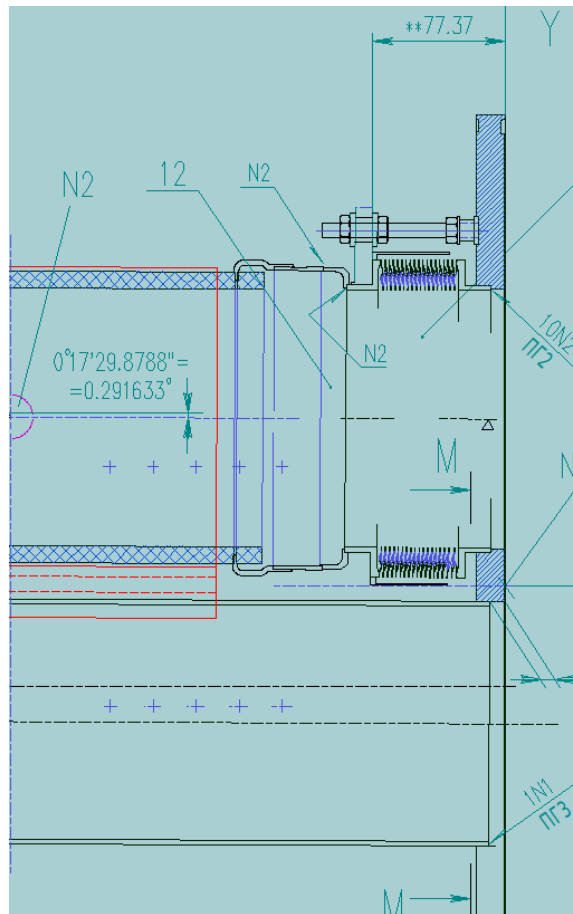
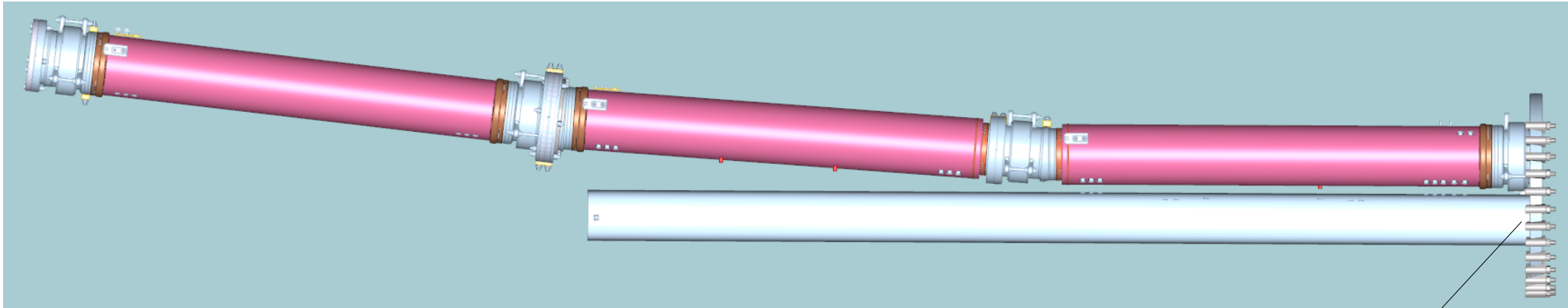

Vacuum chamber

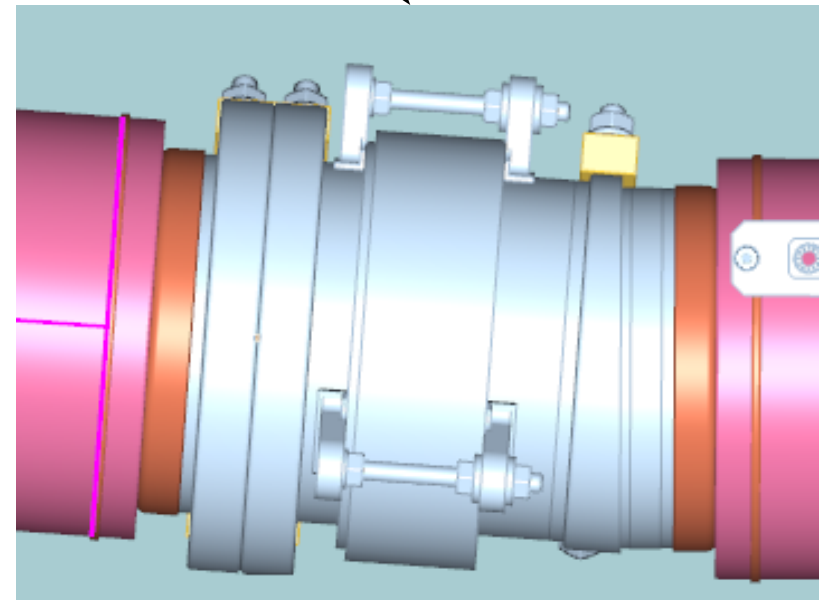
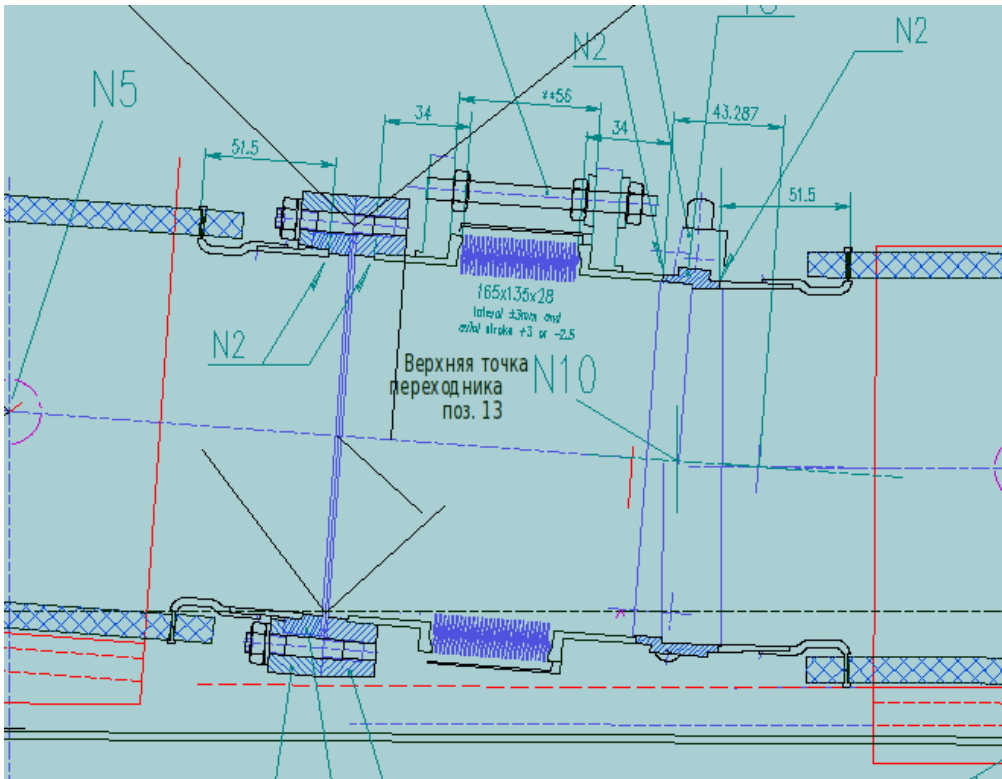
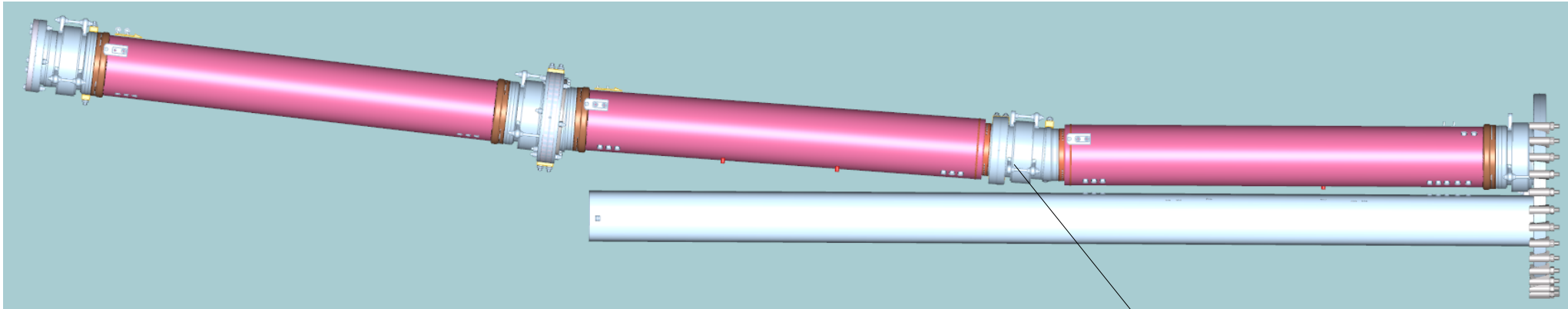

Magnet to magnet difference

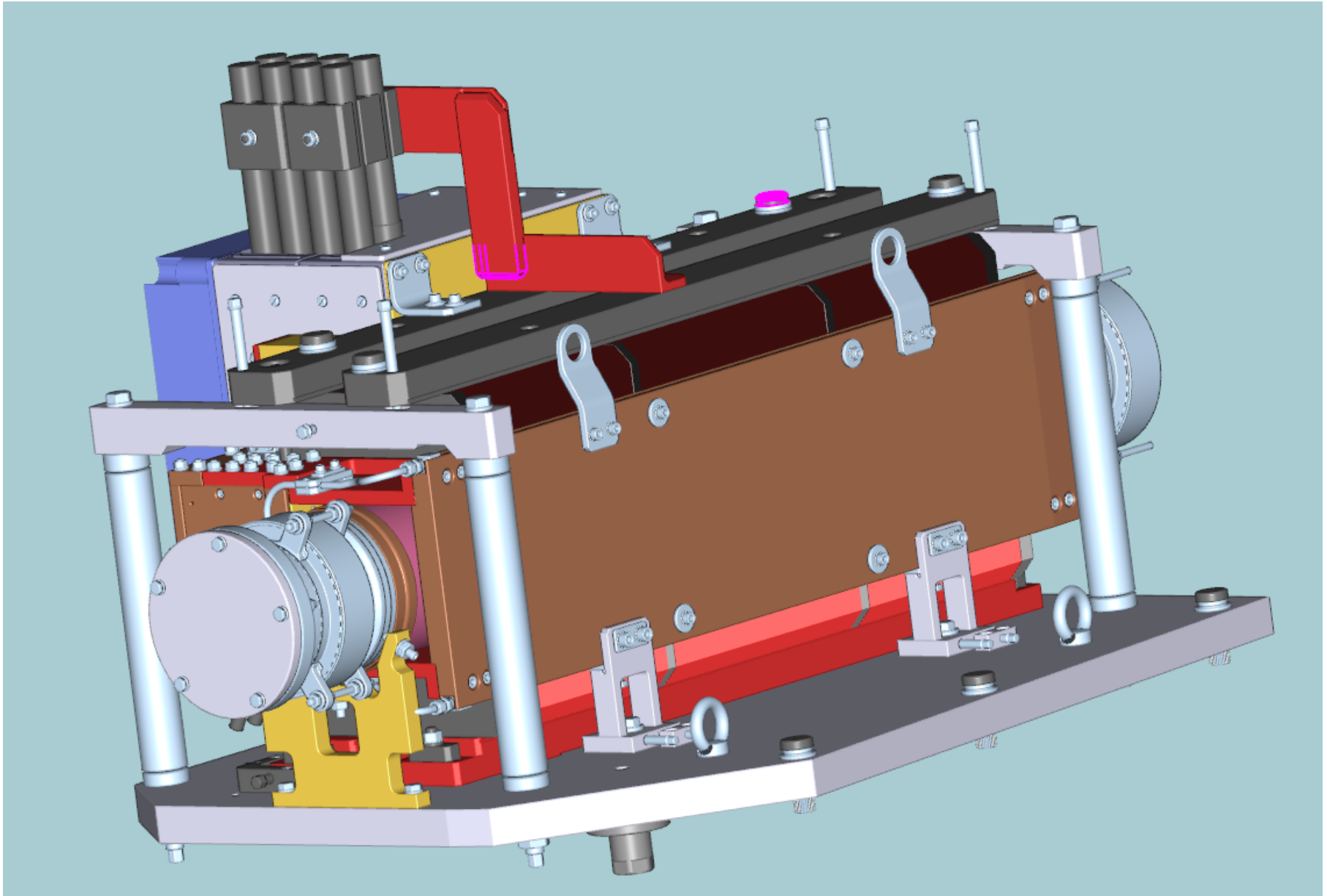

Thank you!