

Vertical steering magnets for CR. CDR Review.

A. Tsyganov for CR team

BINP, Novosibirsk

May 23, 2019

2st FAIR Workshop, Darmstadt, Germany

Outline

1. CDR documentation
2. Project management structure
3. Purpose and Basic Principles
4. Quantity in CR
5. Magnetic simulations
6. Risk analysis
7. Production and realization – manufacturing process chart
8. Production plan

CDR Documentations

The Detailed Specification is outlined in EDMS

<https://edms.cern.ch/ui/#!/master/navigator/document?P:1987795909:1615665351:subDocs>

The set of documents for the *CR_Vertical Steering Magnets, TCR1_Vertical Steering Magnets (AID:0002502)* is given in EDMS

3D-model

<https://edms.cern.ch/ui/#!/master/navigator/document?D:100352984:100352984:subDocs>

Quality plan, Magnetic measurements plan

<https://edms.cern.ch/ui/#!/master/navigator/document?D:100352980:100352980:subDocs>

Risk analysis and hazard analysis

<https://edms.cern.ch/ui/#!/master/navigator/document?D:100352976:100352976:subDocs>

Installation and operation manual

<https://edms.cern.ch/ui/#!/master/navigator/document?D:100352978:100352978:subDocs>

Project Management Structure

- ***Work Package Leader (WPL)***

Name: *Alexander Starostenko* (A.A.Starostenko@inp.nsk.su, Head of BINP Division № 5-11)

The Project Manager is responsible for:

- Follow-up of production activities;
- Regular and timely reporting on progress and problems;
- Timely conduction/participation of reviews and provisions of feedback;

- ***Deputies***

Name: *Alexander Tsyganov* (A.S.Tsygunov@inp.nsk.su, Research Scientist)

The Deputy is responsible for:

- Development of the technical documentation and manufacturing drawings for the deliverables;
- Ensuring that the production of the magnets is according to the technical specifications and time schedule;
- Preliminary magnet design, final magnet design (development, simulation);
- Follow-up of production activities;
- Magnetic measurements to ensure the required field and field quality;
- Transportation, delivery of the equipment to the FAIR site;
- Factory Acceptance Test (FAT) to verify the given specifications of the components;

Name: *Tatyana Rybitskaya* (T.V.Rybitskaya@inp.nsk.su, Research Scientist)

The Deputy is responsible for:

- Magnetic field calculation;

- ***Scientific Design Department***

Name: *Andrey Molokoedov* (A.M.Molokoedov@inp.nsk.su, Principal Design Engineer)

The Principal Design Engineer is responsible for:

- Vertical steering design (3D-models, production drawings);

Details in "Quality Plan"

Purpose and Basic Principles

Vertical steering magnets are used to create a magnetic field of high quality for small-angle correction the of charged particle beam trajectories in the CR of FAIR.

These steering are O-Shape magnets.

These coils of steerer are made of copper bar, which is cooled in the air.

This corrector is combined with the BPM (Type1).

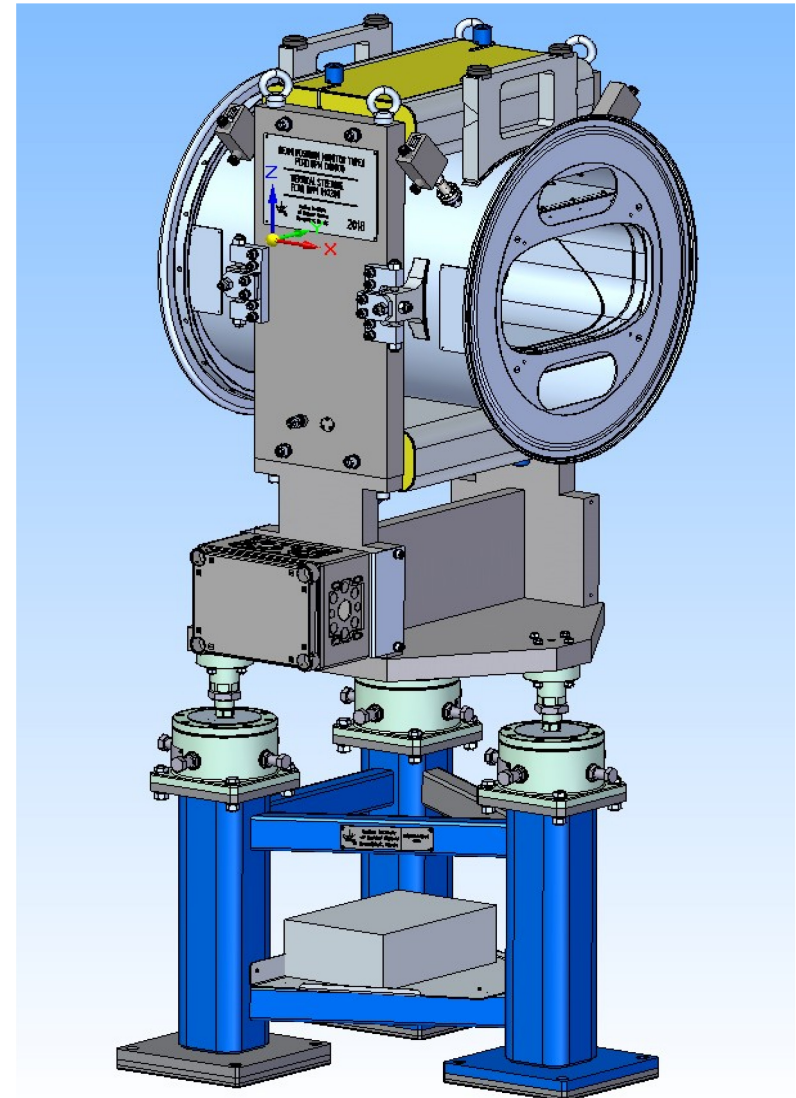

Quantity in CR

- 18 vertical steering magnets : 14 in arcs, 3 in TCR1.

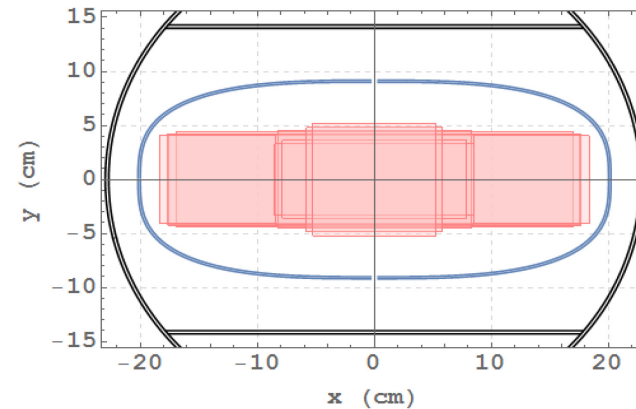
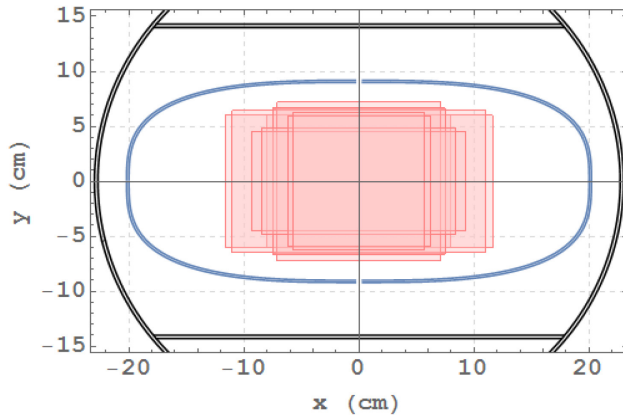

Approximately 400 x 200 mm of useful aperture and maximum beam size at different points along the CR arcs: pbar – left, ions – right (Figs from CDR of BPM - TYPE 1)

The 3D model of vertical steering magnet and drawings are ready.

Magnetic simulation

The simulation model of vertical steering magnet.

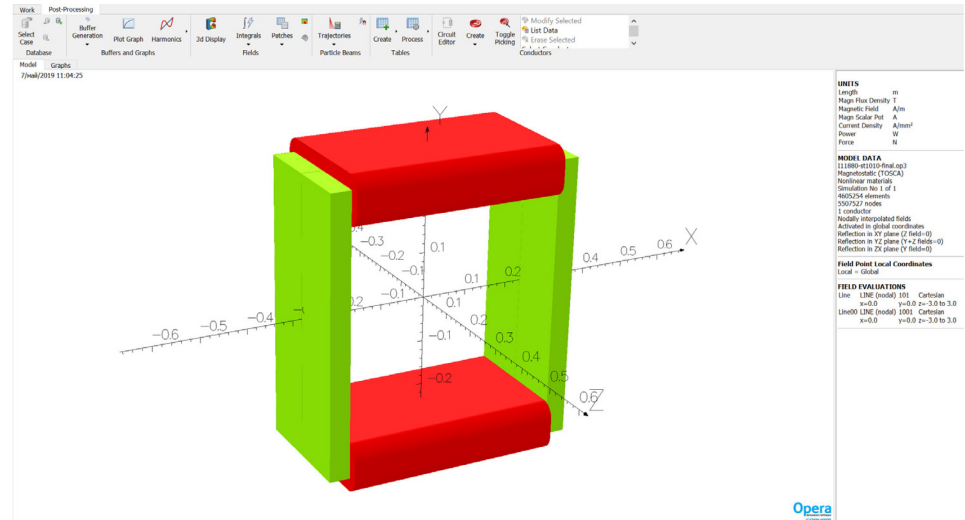

The magnetic saturation in the yoke.
Units of measure [T].

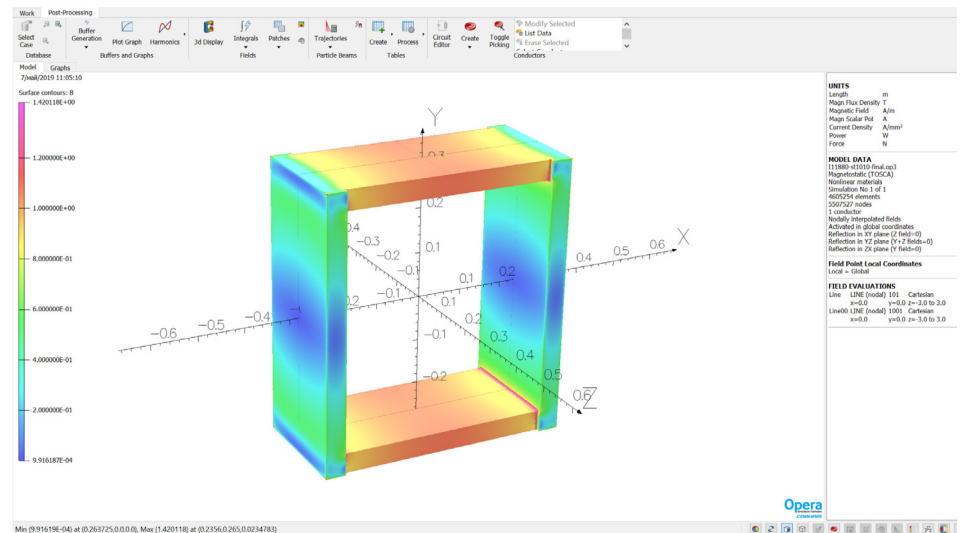

Magnetic simulation

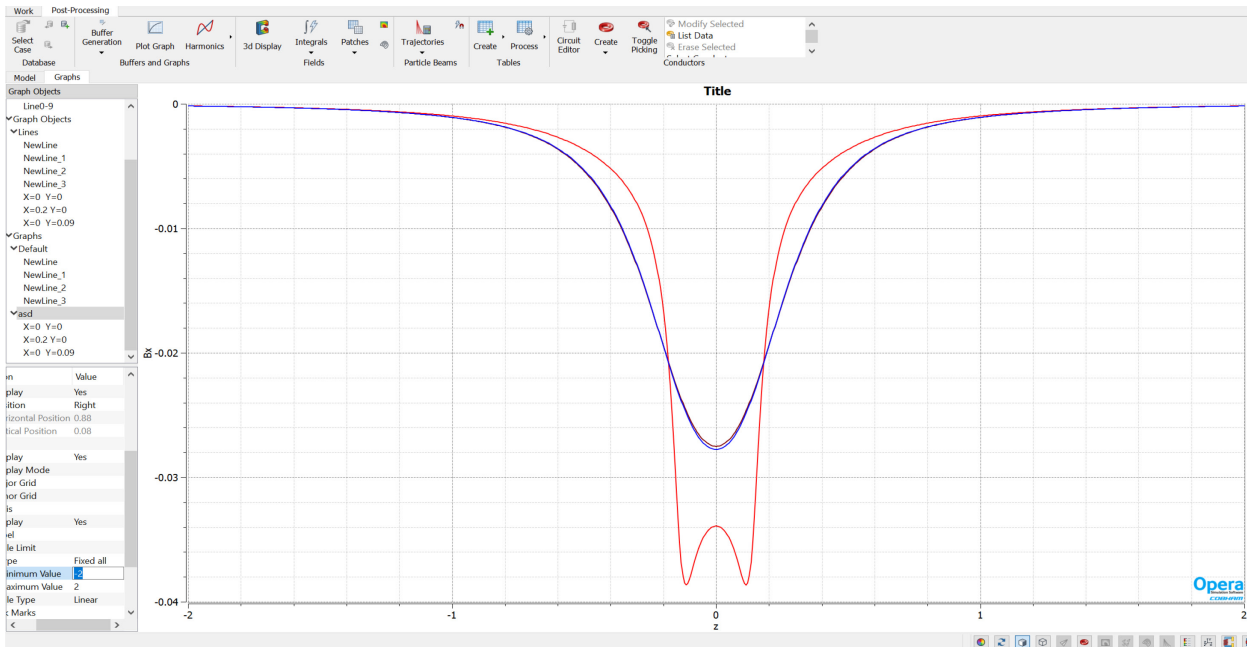

The simulation of magnetic fields B_x [T] along Z [m] for different X and Y

The values of the integral $\int B_x dz$ for different X and Y

X [m]	Y [m]	$\int B_x dz$ [T·m]
0	0	-0.02014
0.2	0	-0.02038
0	0.09	-0.02012

Between the maximum and minimum values of the integral $\int B_x dz$ difference +/- 0.65%

Main parameters for vertical steering magnets

Parameter	Value	Units
Maximum field integral	0.02	T·m
Field quality, $\int \Delta B_x / \int B_x$	± 1.5	%
Overall weight without stand	560	kg
External radius of the vacuum chamber in the steering magnet	230	mm
Usable aperture	Super ellipse $x=\pm 200, y=\pm 90$	mm
Effective length	740	mm
Packing factor	solid	
BH-curve	M1200-100A or AISI 1010	
Yoke length	270	mm
Iron weight without stand	390	kg
Current density in conductor	1.1	A/mm ²
Total number of turns per magnet	2376	
Conductor cross section	2.24x4	mm ²
Copper weight per magnet	166	kg
Current at max field	10	A
Power consumption	320	W
Resistance per magnet	3.2	Ohm

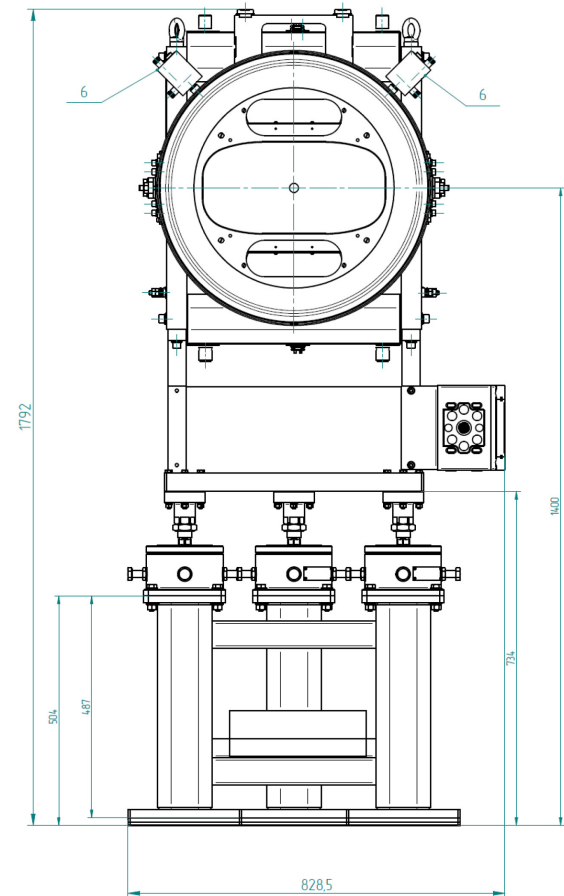
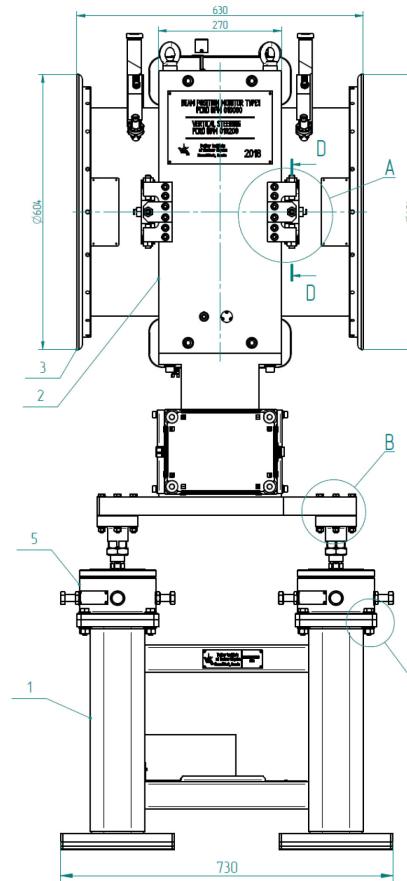

Details available in EDMS:

<https://edms.cern.ch/ui/#!master/navigator/document?P:1987795909:1615665351:subDocs>

Risk Assessment Table (I)

Risk Log		Risk Identification			Risk Rating Pre-Mitigation			Risk Mitigation			Post-Mitigation Risk Rating		
Risk ID	No	Description of Risk (orientating to the hazard)	Life cycle	Possible consequences	Probability of Occurrence	Impact	Risk Level	Mitigation Strategy			Probability of Occurrence	Impact	Risk Level
TECHNICAL RISKS													
Mechanical hazards													
RL-001	1	Dent in the magnet (pole)	BCI	Damage of parts of the magnet; Performance below specification; Failed to reach the required field quality	2	3	2	Check that fastening bolts between the yoke plates and blocks are correctly tightened; Check that lifting eye bolts are correctly tightened; Check that used chains, straps and hooks have the weight rating adapted to the magnet weight, corresponding number of attachment points and corresponding lifting angles. Magnet must be properly fastened to a suitable stand to prevent any fall during installation, operation, maintenance and storage. Obey warning signs and boundaries. Follow handling and installation instructions according to the BINP Installation and Operation Manual, FCRD_BPM_Installation_Operation_manual_A.			1	3	2
RL-002	2	Failure of welding joints	ABCI	Damage of parts of the magnet	2	3	2	Carry out inspection of welding lines on a regular basis. Follow handling and installation instructions according to the BINP Installation and Operation Manual, FCRD_BPM_Installation_Operation_manual_A.			1	3	2
RL-003	3	Failure of brazing joints	ABCI	Damage of parts of the magnet;	2	3	2	Carry out inspection of brazing joints on a regular basis. Follow handling and installation instructions according to the BINP Installation and Operation Manual, FCRD_BPM_Installation_Operation_manual_A.			1	3	2
RL-004	4	Magnet falling during handling	BCI	Damage of parts of the magnet up to complete loss of the magnet; Personnel injury	2	4	3	Check that fastening bolts between the yoke plates and blocks are correctly tightened; Check that lifting eye bolts are correctly tightened; Check that used chains, straps and hooks have the weight rating adapted to the magnet weight, corresponding number of attachment points and corresponding lifting angles. Magnet must be properly fastened to a suitable stand to prevent any fall during installation, operation, maintenance and storage. Obey warning signs and boundaries. Follow handling and installation instructions according to the BINP Installation and Operation Manual, FCRD_BPM_Installation_Operation_manual_A.			1	4	2
Electrical hazards													
RL-005	5	Contact with live parts	ACDF GHI	Electrical shock; Personnel injury	1	1	1	Electrical equipment must be de-energized before work is conducted unless special exceptions exist. Only qualified and authorized personnel may work with or near live parts, and only with a valid Electrical Work Permit. Rule out accidental touching of live parts while an employee works with or near them. Use proper Personal Protective Equipment. Obey warning signs and boundaries.			1	1	1
RL-006	6	Cracks or breaks in the insulation (turn-to-turn insulation, layer-to-layer insulation, coil-to-yoke insulation)	CI	Loss of equipment functionality; Short circuits and fire	2	3	2	Carry out inspection of insulation (including thermal imaging) on a regular basis. Follow handling and installation instructions according to the BINP Installation and Operation Manual, FCRD_BPM_Installation_Operation_manual_A.			1	3	2
RL-007	7	Cable breaks (power, diagnostic, etc.) including cracks or breaks in the insulation, failure of cable connections	CI	Loss of equipment functionality; Electrical shock; Fire; Personnel injury	2	3	2	Cables must be labelled. Cables must be traceable, viewable and accessible. Cables must be protected from mechanical damage. Avoid creating stumbling hazards with cables. Regular inspection of insulation and connections. Braked cables must be marked, apply a do-not-use tag. Braked cables must be replaced.			1	3	2

Risk Assessment Table (II)

RL-008	8	Thermoswitch internal interlock failure (temperature of coil)	D	Coils overheating	1	3	2	Check visually/electrically the continuity of thermoswitches. De-energize magnet in case of coils overheating.	1	3	2
RL-009	9	Power/ power supply failure (supply interrupted due to external reason)	D	Loss of equipment functionality	2	1	1	Does not require any action (supply interrupted due to external reason).	2	1	1
RL-010	10	Magnet still energized	ALL excluding BEJ	Would be no consequences	1	1	1	Does not require any action (would be no consequences).	1	1	1
RL-011	11	Work with power tools	ALL excluding BD	Electrical shock; Personnel injury	1	1	1	Maintain tools so they are in good condition. Inspect tools before each use. Use the right tool for the job. Use tools in accordance with manufacturers' instructions. Obey all labels and instructions. Worn-out tools must be marked, apply a do-not-use tag. Worn-out tools must be replaced.	1	1	1
		Humidity hazards									
RL-012	12	Dysfunctioning of thermoswitches	CGHI	Risk of coils overheat	2	2	1	Follow installation instructions according to the BINP Installation and Operation Manual, FCRD_BPM_Installation_Operation_manual_A.	1	2	1
RL-014	14	High air humidity in the environment around the magnet	BD	Corrosion	4	1	1	Magnets will be packed for transportation under the conditions to avoid contact of product with rain water, spatter or condensates. Use climate-control system in the tunnel. Carry out preventive diagnostic measures in the tunnel on a regular basis.	3	1	1
		Thermal hazards									
RL-015	15	Fire/high temperature also origin of noxious gases (initiator inside/outside of the magnet)	ALL excluding BEJ	Equipment failure up to complete loss of the magnet; Personnel injury	1	5	2	Use fire supervision system in the tunnel. Carry out preventive diagnostic measures in the tunnel on a regular basis. Use automatic fire suppression system in the tunnel. Use fire-proof and non-toxic materials. Verify that the area is free from unnecessary inflammables. Follow the GSI Safety Regulations. Complete the required GSI Safety Trainings.	1	5	2
		Radiation hazards									
RL-016	16	Accidental release of radiation to the tunnel environment (initiator fire and/or mechanical damage to the equipment)	D	Tunnel environment radioactive contamination; Workers exposure to radiation; Difficulties to repair and maintenance of equipment	1	5	2	Use radioactivity supervision system in the tunnel. Carry out preventive diagnostic measures in the tunnel on a regular basis. Follow the GSI Safety Regulations. Complete the required GSI Safety Trainings.	1	5	2

Risk Assessment Table (III)

		Magnetic field hazards									
RL-017	17	Magnetic field	ALL excluding BEJ	Personnel injury	1	1	1	The area surrounding the magnet is not recommended to the people carrying a pacemaker. Obey warning signs and boundaries.	1	1	1
RL-018	18	Magnetizable objects	D	Equipment failure	4	1	1	Do not use magnetizable tools when the magnet is powered.	2	1	1
		Ergonomic hazards									
RL-019	19	Accidents of the magnet sharp edges	ALL	Personnel injury	3	1	1	Use the rubber corner bumpers. Use the basic Personal Protective Equipment (hard hats, safety glasses, steel tip shoes).	2	1	1
		Combination of hazards									
RL-020	20	Design alteration and/or performance below specification	A	Delays to the schedule; Failed to reach the required field quality	3	3	3	The Parties shall monitor the scientific and technical progress of the Collaboration Contract activities. The Parties shall clarify the Technical Specifications during the project development. (Risk originated mainly from unpredictable deviation of the magnetic susceptibility of the stainless steel material of vertical steerers vacuum chambers from the specified low value.)	2	3	2
RL-021	21	Lack of knowledge about GSI site, GSI safety regulations and procedures	ALL excluding AB	Damage to the personnel health due to hazards created by others	2	1	1	The Parties shall coordinate efforts to create and maintain a clean and organized work environment. Follow the GSI Safety Regulations. Complete the required GSI Safety Trainings.	1	1	1

Based on Arrangement of Risks

Includes: Mechanical, Electrical, Thermal, Humidity, Radiation, Magnetic, Ergonomic and Combined hazards.

Ranges risk hazards on its impacts and propose Mitigation Actions

Manufacturing Process Chart

Acronyms and Abbreviations:

P	The yoke parts production
PM1	Milling the yoke parts
PC1	Checking the dimensions and the holes' positions of the yoke parts during production.
PC2	Checking the number and types of yoke parts.
PK1	Marking parts of the yoke.
Y	Yoke production
YC1	Check completeness (availability of all parts and fasteners)
YA1	Assembling of yoke parts procedure.
YC2	Check the assembling.
YM1	Processing of the assembled yoke
YC3	Check the dimensions of the machining.
YC4	Visual check the paintwork.
C	Coil production
CW1	Coil winding procedure.
CC1	Check dimensions and interturn insulation of the coils before impregnation.
CP2	Coil impregnation procedure.
CC2	Check dimensions of the coils after the impregnation.
CP3	Brazing procedure for external brazing.
CP4	Electrical tests of the coils.
A	Magnet assembly
AP1	Magnets assembly procedure.
AC1	Check the magnet dimensions.
AC2	Electrical tests procedure.
AP4	Magnetic measurements procedure.
AP5	Final tuning procedure if necessary. General acceptance. FAT. Packing.

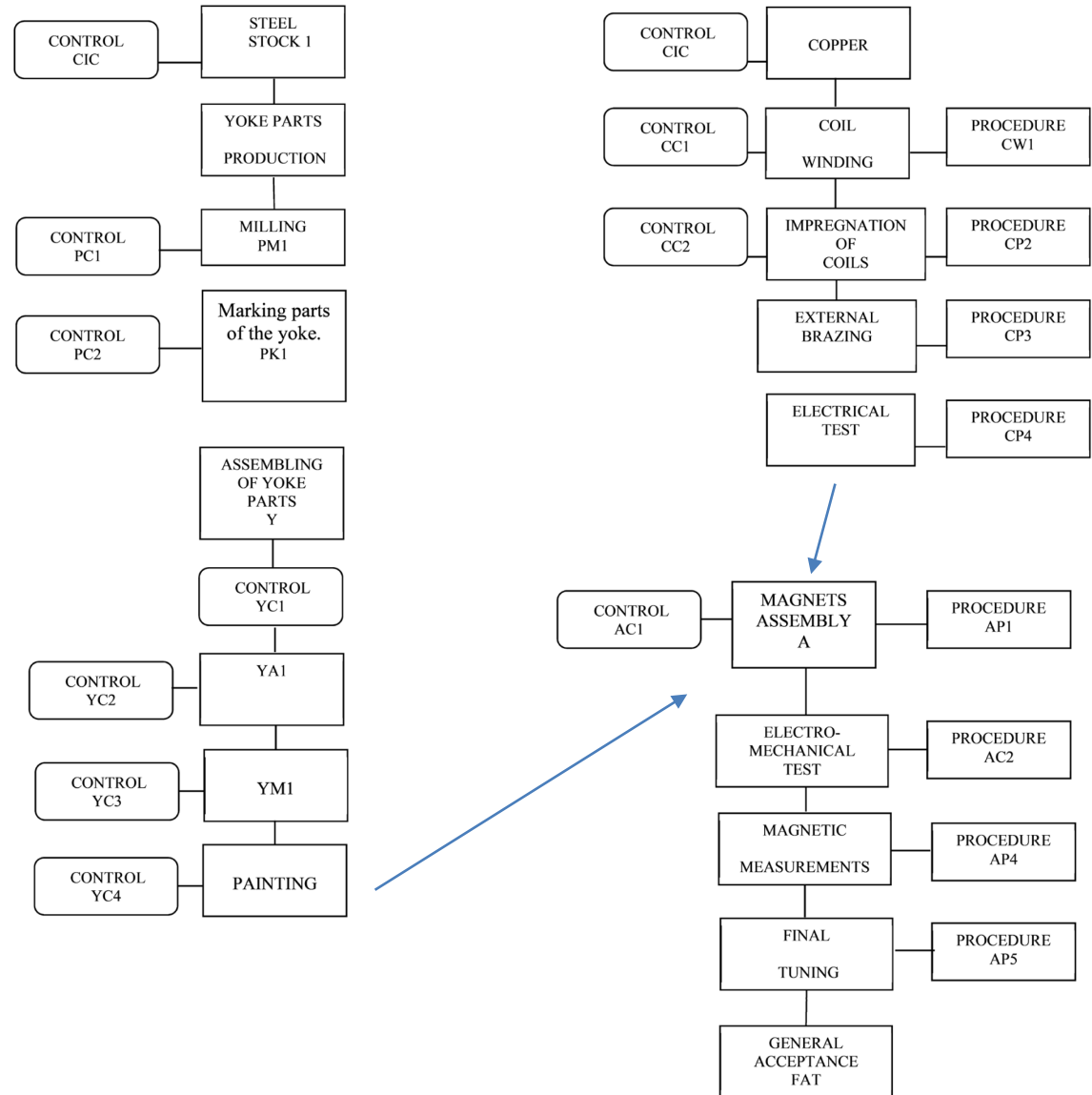

Milestones

- April 2019 – May 2019: preparation and **passing milestone M6 (CDR)**
- June 2019 – August 2019: detail designing, preparation of drawings. **Passing milestone M7 (FDR)**. Purchasing required accessories, materials, components
- August 2019 – October 2019: tooling production, test bench development and production, manufacturing and to experimental workshop-1 (EW-1)
- November 2019 – December 2019: **FoS testing, QA, magnetic measure, FoS revision. Passing milestone M8**
- November 2019 – November 2022: manufacturing and testing the other vertical steering magnets, FAT, delivering to FAIR facility, SAT, pre-installation assembling. Approximately 2 vertical steering magnets every 4 month.
- December 2022 – February 2023: final installation in CR tunnel [**All series M10 – January 2023**]

Summary

- Quality plan is prepared and uploaded to EDMS – Q2-2019
- Risk Analysis is prepared and uploaded to EDMS – Q2-2019
- 3D models is ready and uploaded to EDMS (2D drawings in EW) – Q2-2019
- Production chart and main milestones defined and presented – Q2-2019
- Fos production is started (material procurement as well) – Q4-2019
- Ready for CDR check and approval (protocol signature) for vertical steering magnet – Q2-2019