

Proton and light nuclei flow with HADES

Behruz Kardan

for the
HADES Collaboration

EMMI Workshop

Probing dense baryonic matter with
hadrons: Status and Perspective

GSI, Darmstadt

11-13. February, 2019



H-QM | Helmholtz Research School
Quark Matter Studies

HIC | FAIR
for
Helmholtz International Center

HADES

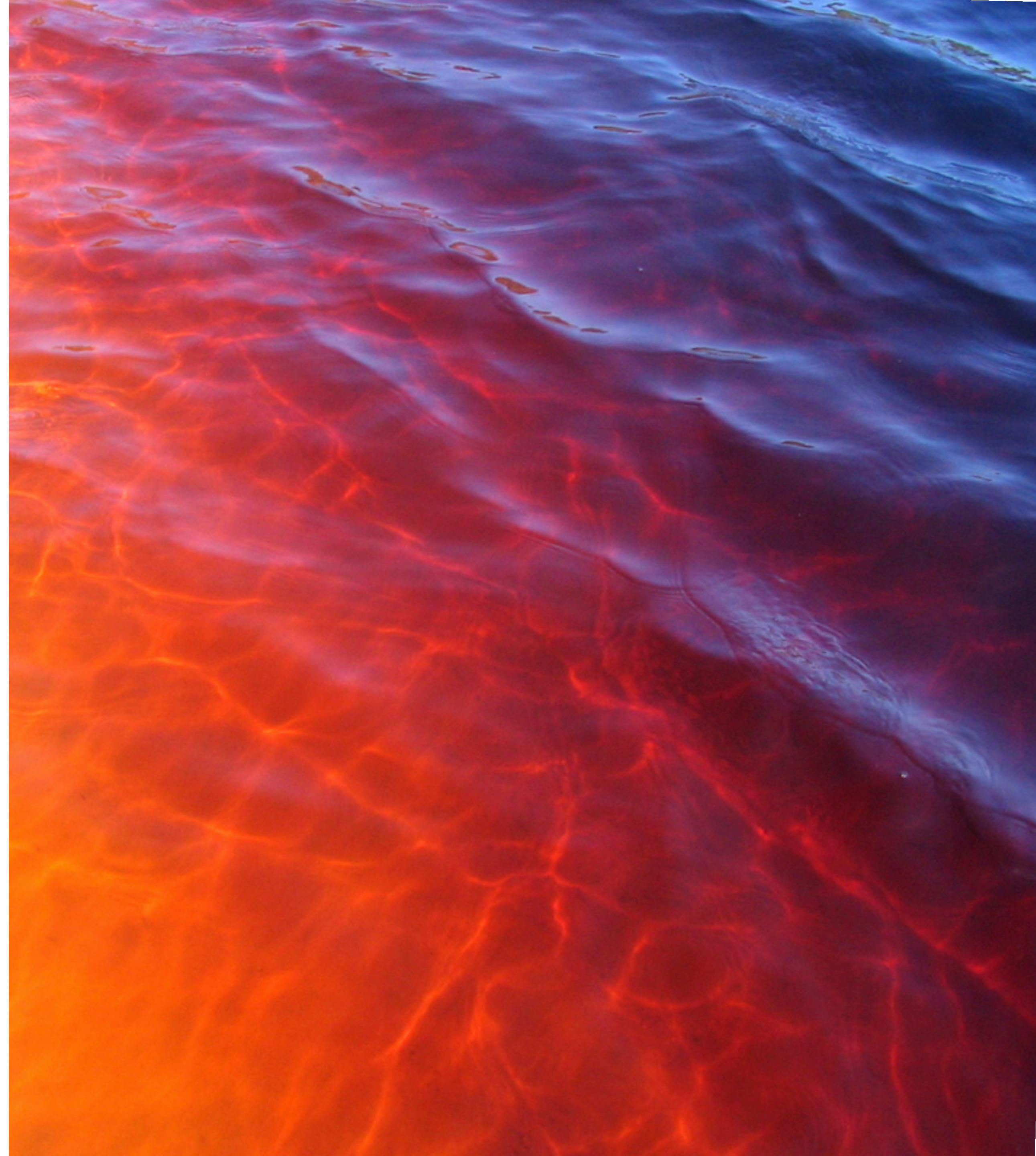

Outline

- Motivation: Equation-of-State
- HADES and Au+Au data at 1.23 AGeV
- Radial flow
 - ▶ Via Blast-Wave analysis and pion HBT
- Directed v_1 , elliptic v_2 , triangular $v_3\{\Psi_{RP}\}$ flow
 - ▶ Of protons, deuterons and tritons
- Quadrangular $v_4\{\Psi_{RP}\}$ flow

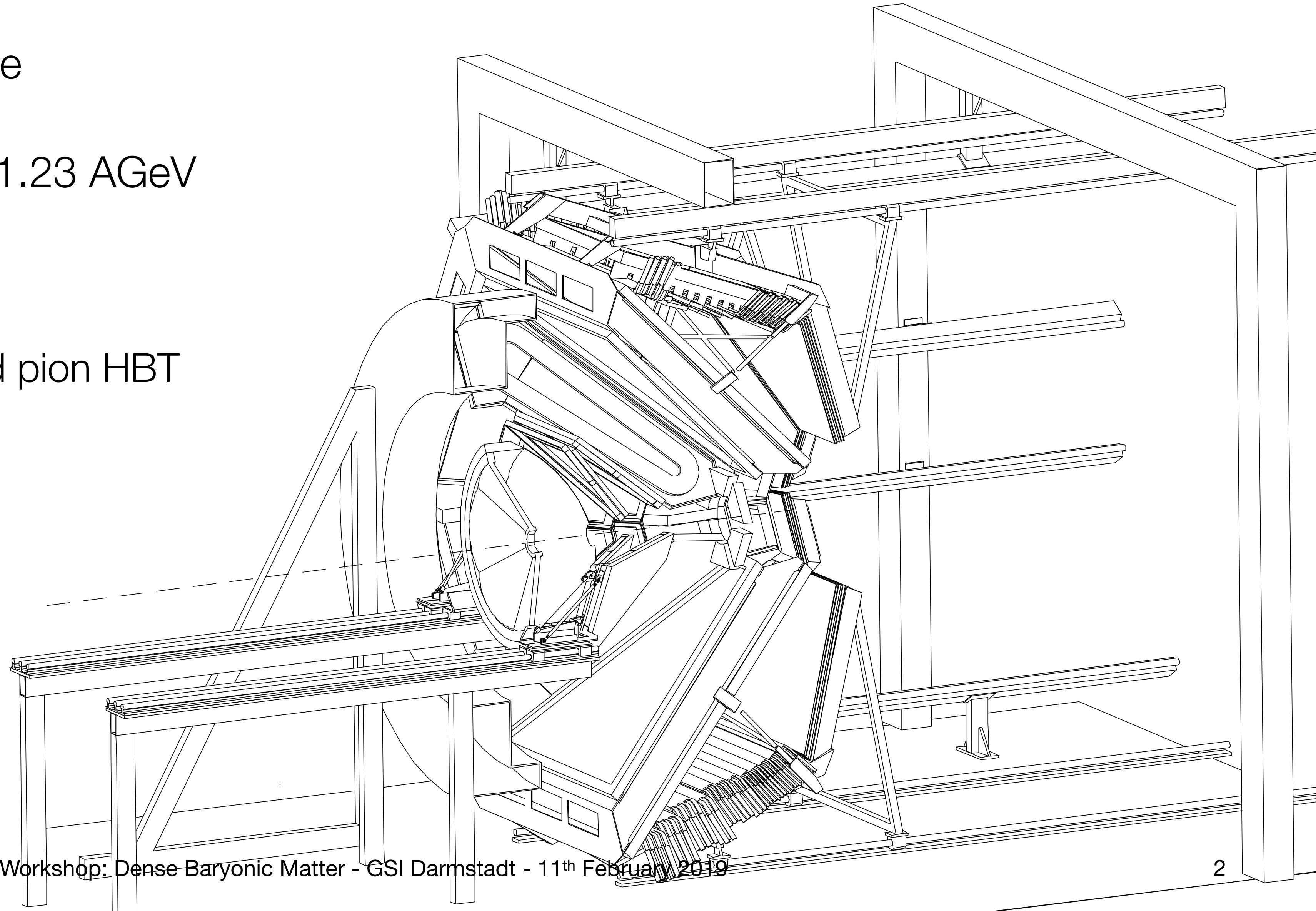

Motivation

Nuclear and Neutron Star Matter

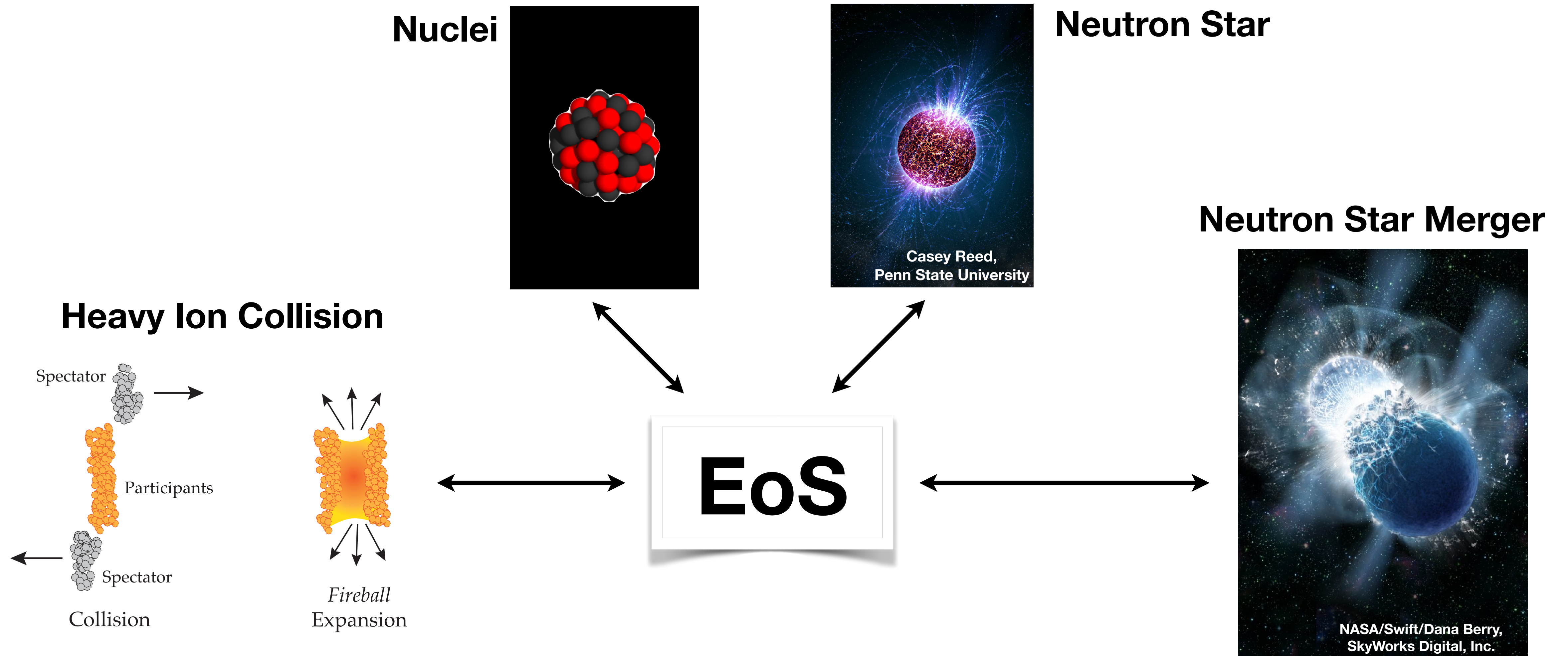

Motivation

Heavy Ion Collisions at 1.23A GeV

- High densities:
 $\rho_{\text{max}} = 1-3\rho_0$
- Moderate temperatures:
 $T = 50-100 \text{ MeV}$
- Relatively long lifetime of fireball
- Significant transverse expansion expected

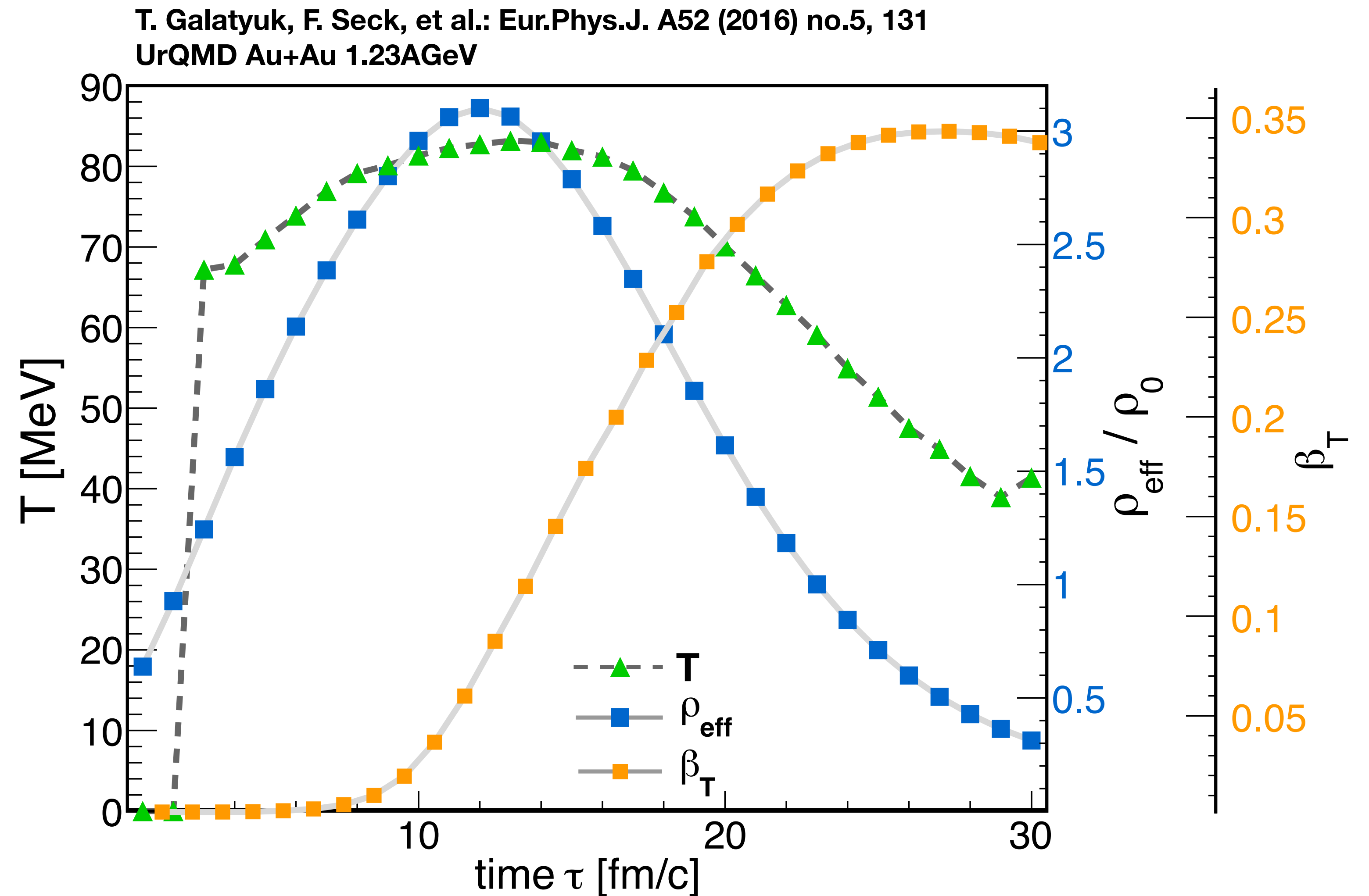

Motivation

Energy Dependence of Direct and Elliptic Flow

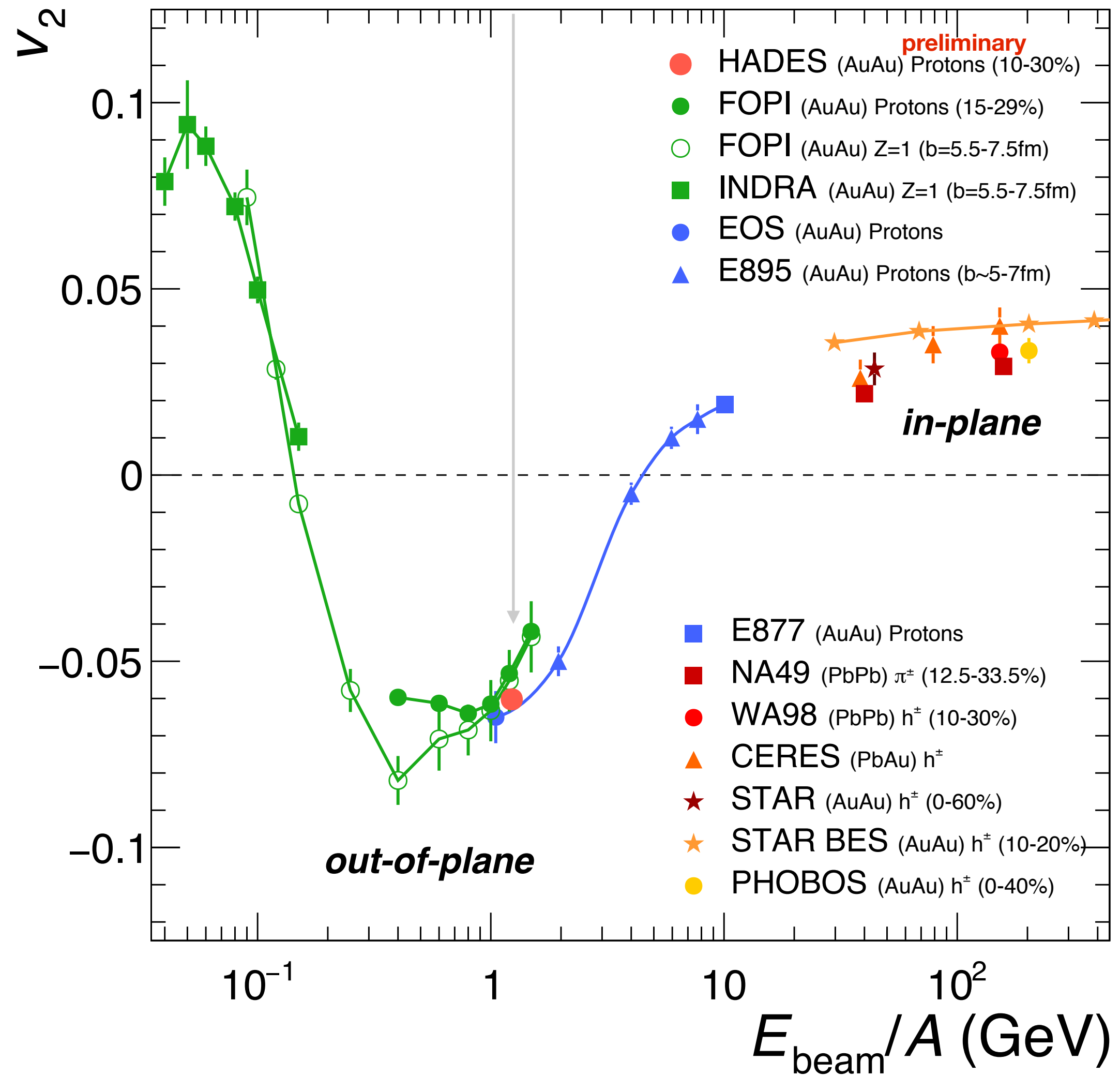
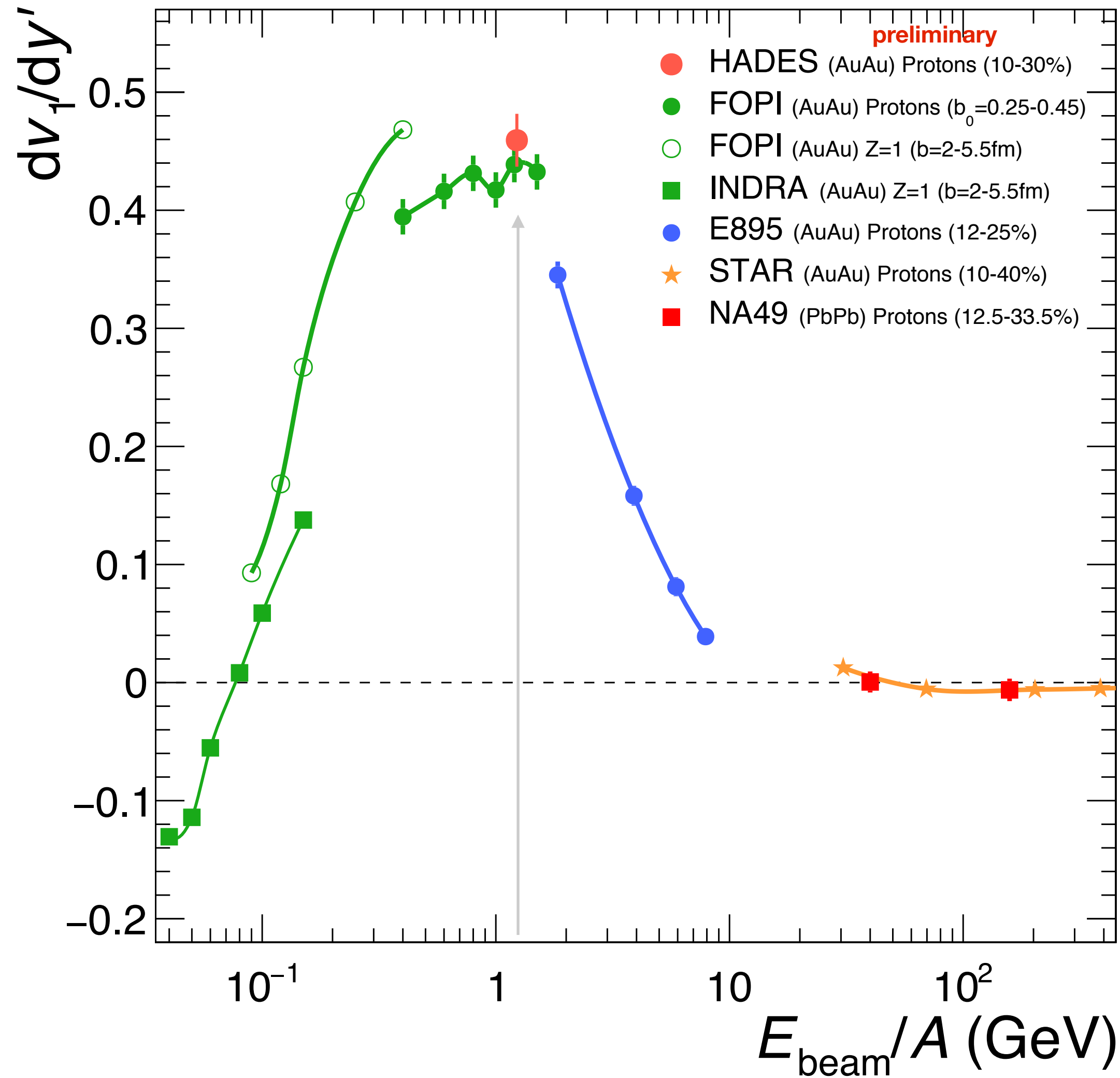

High Acceptance Di-Electron Spectrometer

- Large acceptance
 - ▶ Symmetric azimuthal coverage
 - ▶ 18° - 85° in polar angle
- Tracking system and magnetic spectrometer
 - ▶ 4 planes of low-mass mini-drift chambers (MDC)
 - ▶ Superconducting toroidal magnet
- Forward Wall
 - ▶ Reaction plane reconstruction

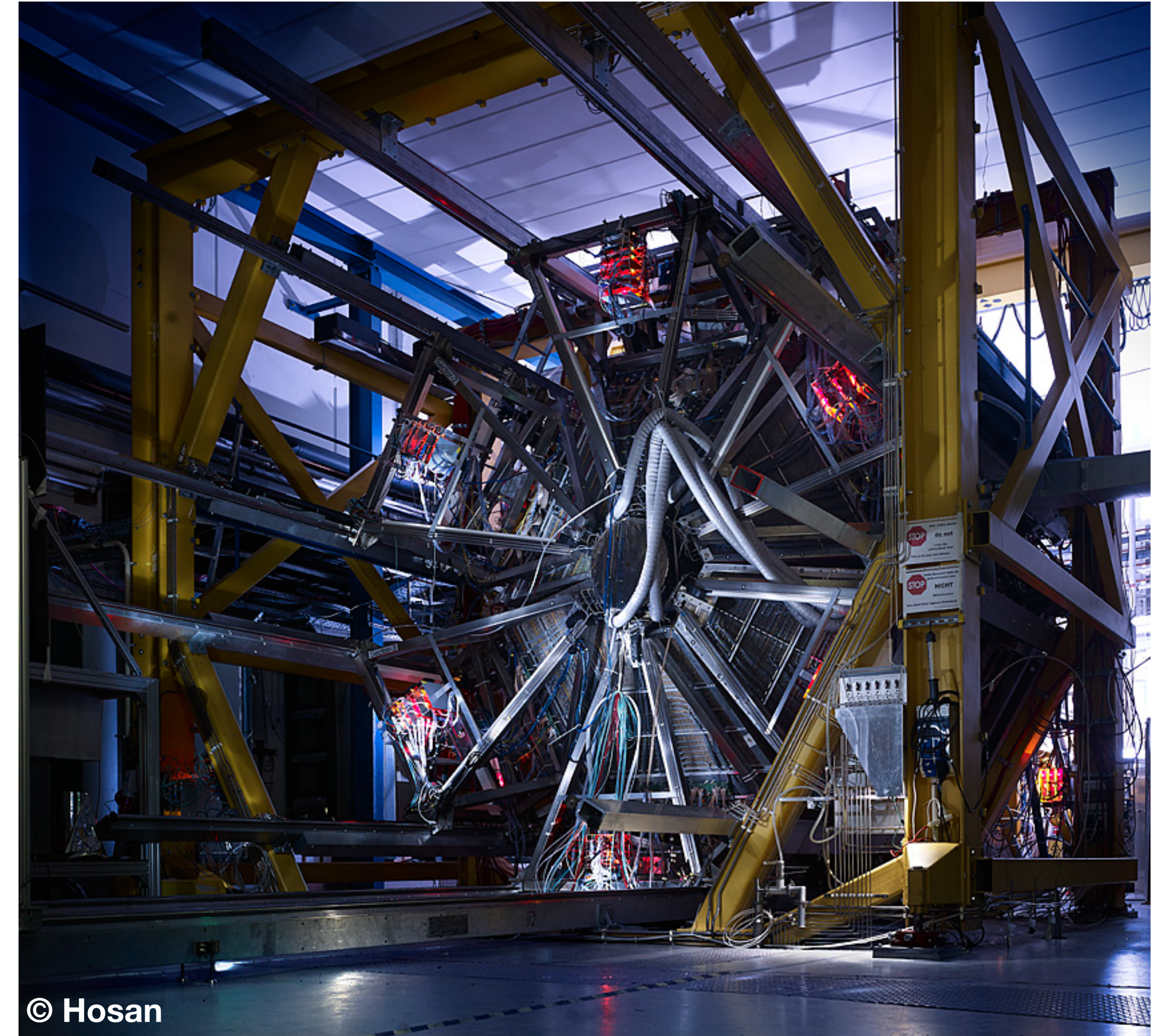

HADES Performance

Event Plane Reconstruction

- Based on hits of projectile spectators in the Forward Wall

$$\vec{Q}_{EP} = \sum_{i=0}^N \vec{u}_i$$

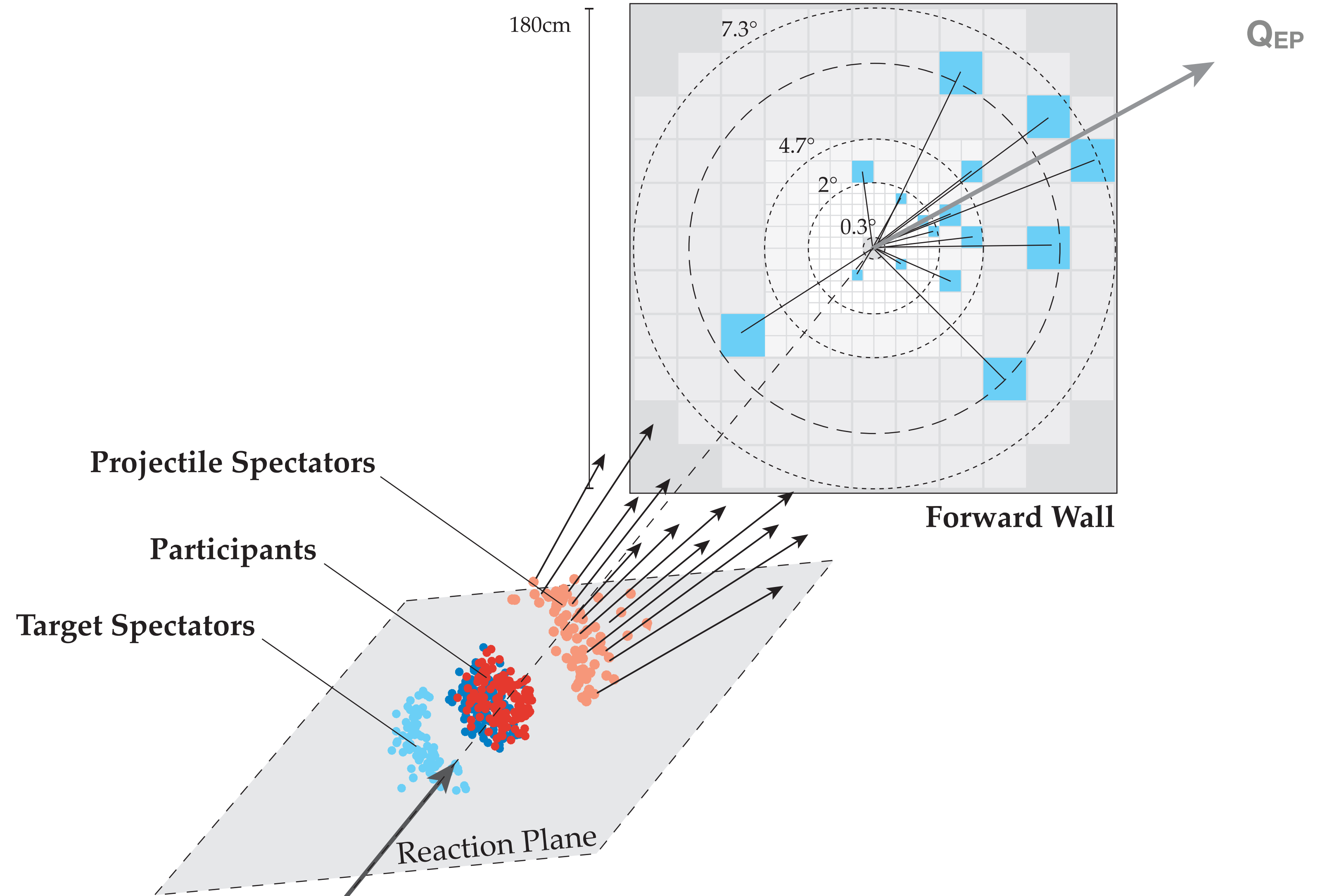

HADES Performance

Event Plane Resolution

- Calculation of full Resolution from sub-event Resolution
- Based on method described in J.-Y. Ollitrault, arXiv:nucl-ex/9711003

$$v_n = v_n^{obs} / \mathcal{R}_n$$

$$\mathcal{R}_n = \langle \cos[n(\Psi_n - \Psi_{RP})] \rangle$$

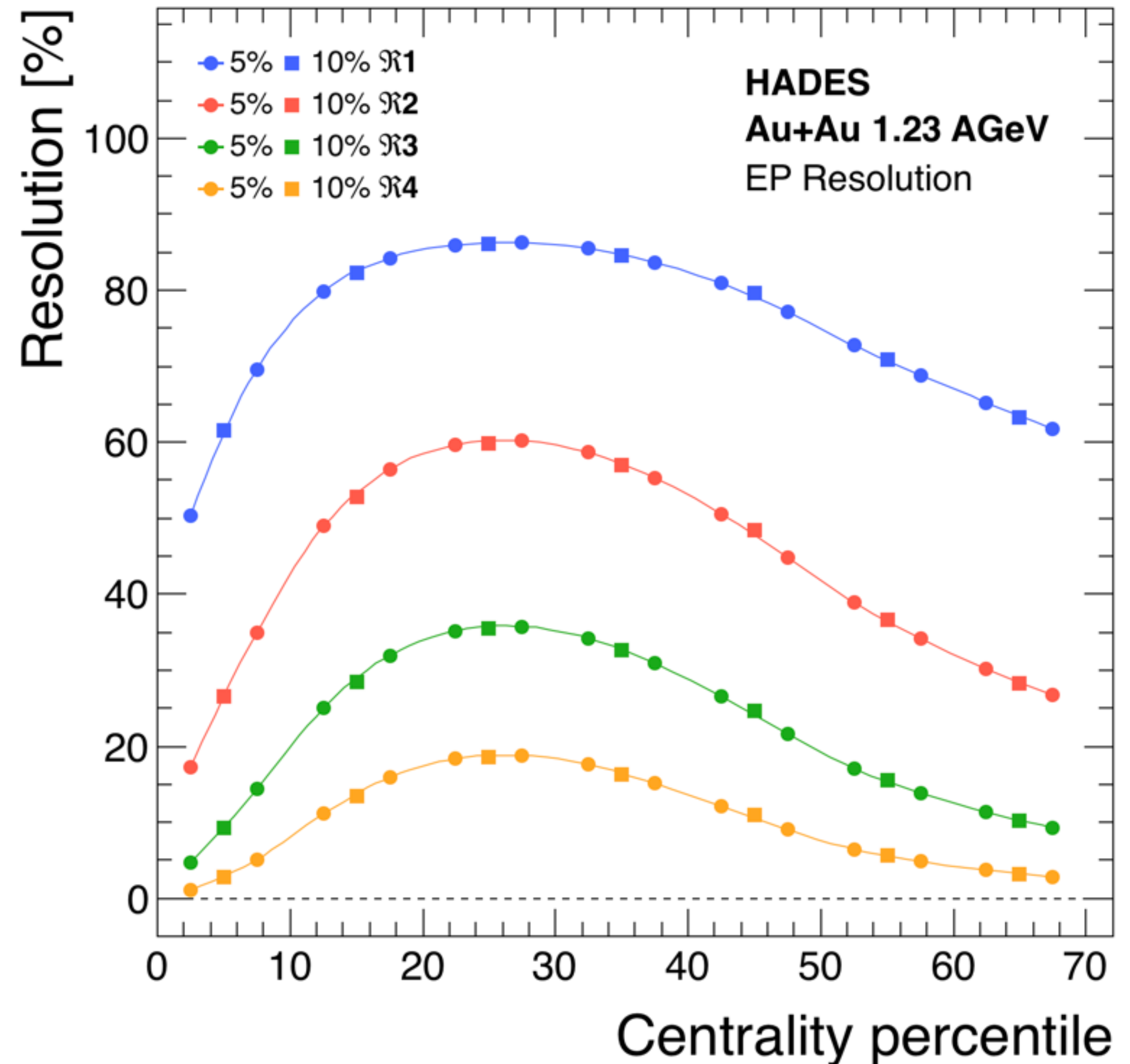

HADES Performance

Particle identification

- Time-of-Flight (TOF and RPC)

- Energy loss in the MDC $Z_{MDC} = \ln\left[\frac{(dE/dx)_{measured}}{(dE/dx)_{proton}}\right]$

▶ Separation deuterons and He

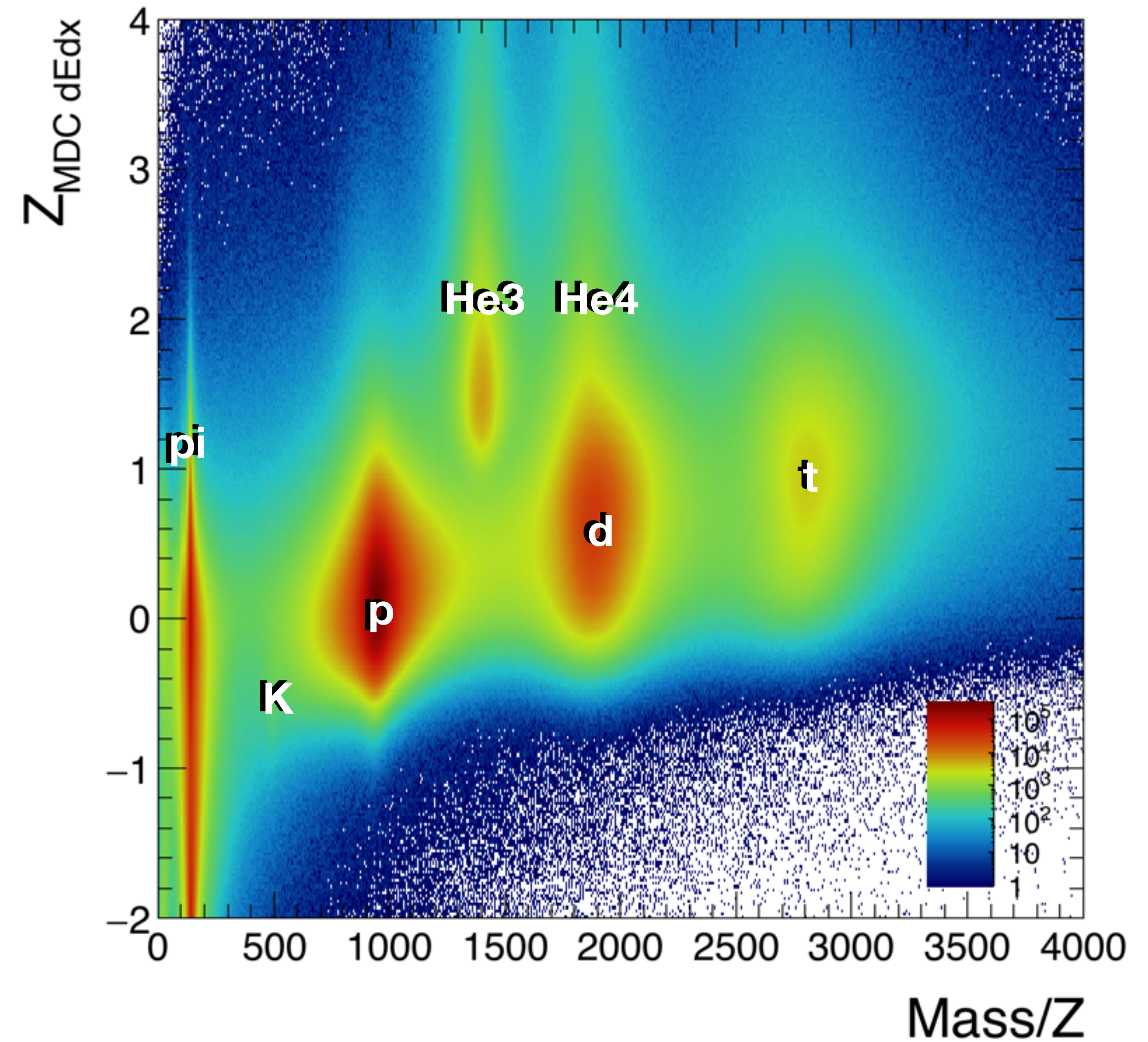
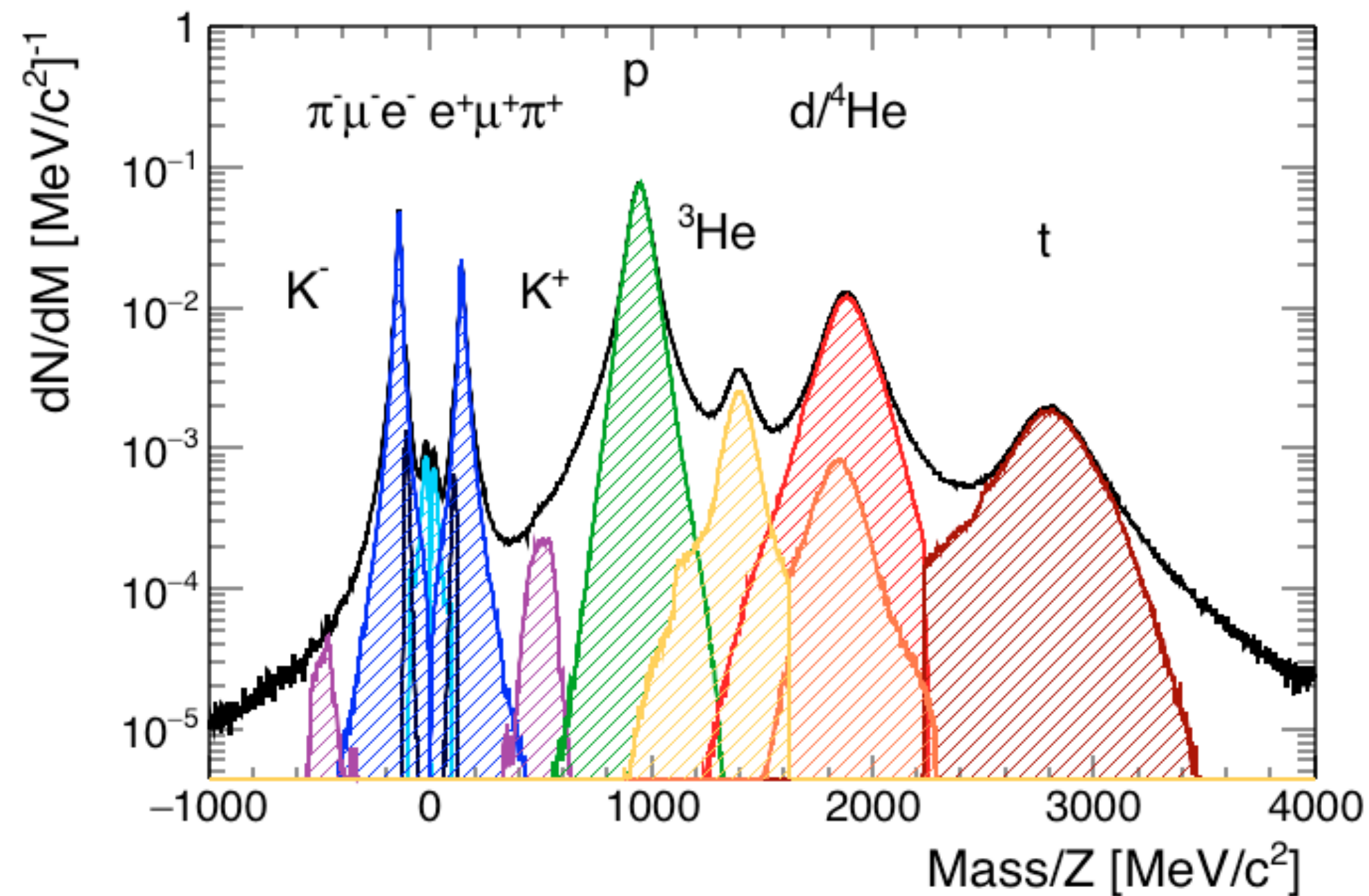

HADES Performance

Proton Spectra

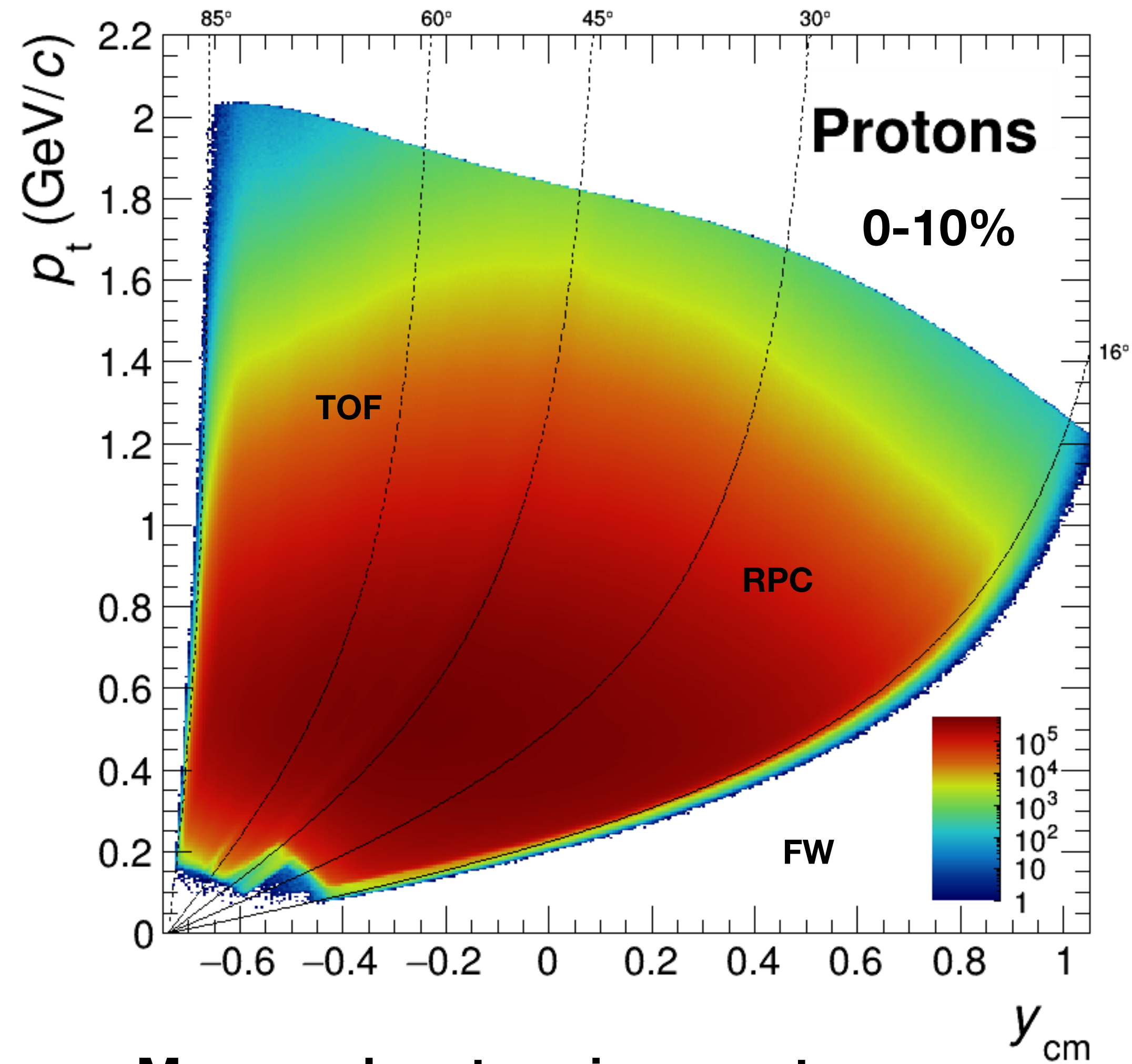

Measured protons in acceptance

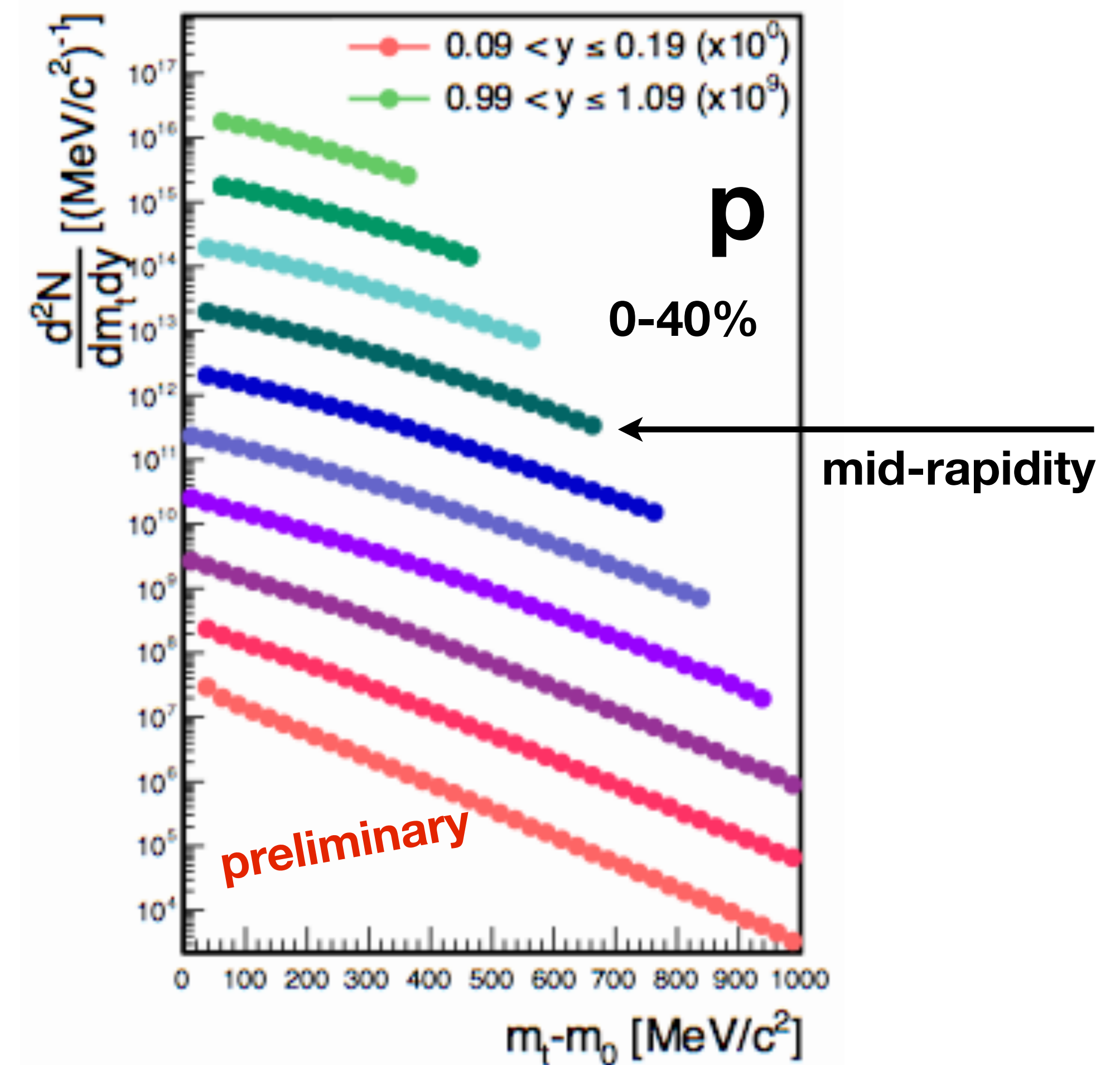

HADES Performance

Acceptance for Deuterons and Tritons

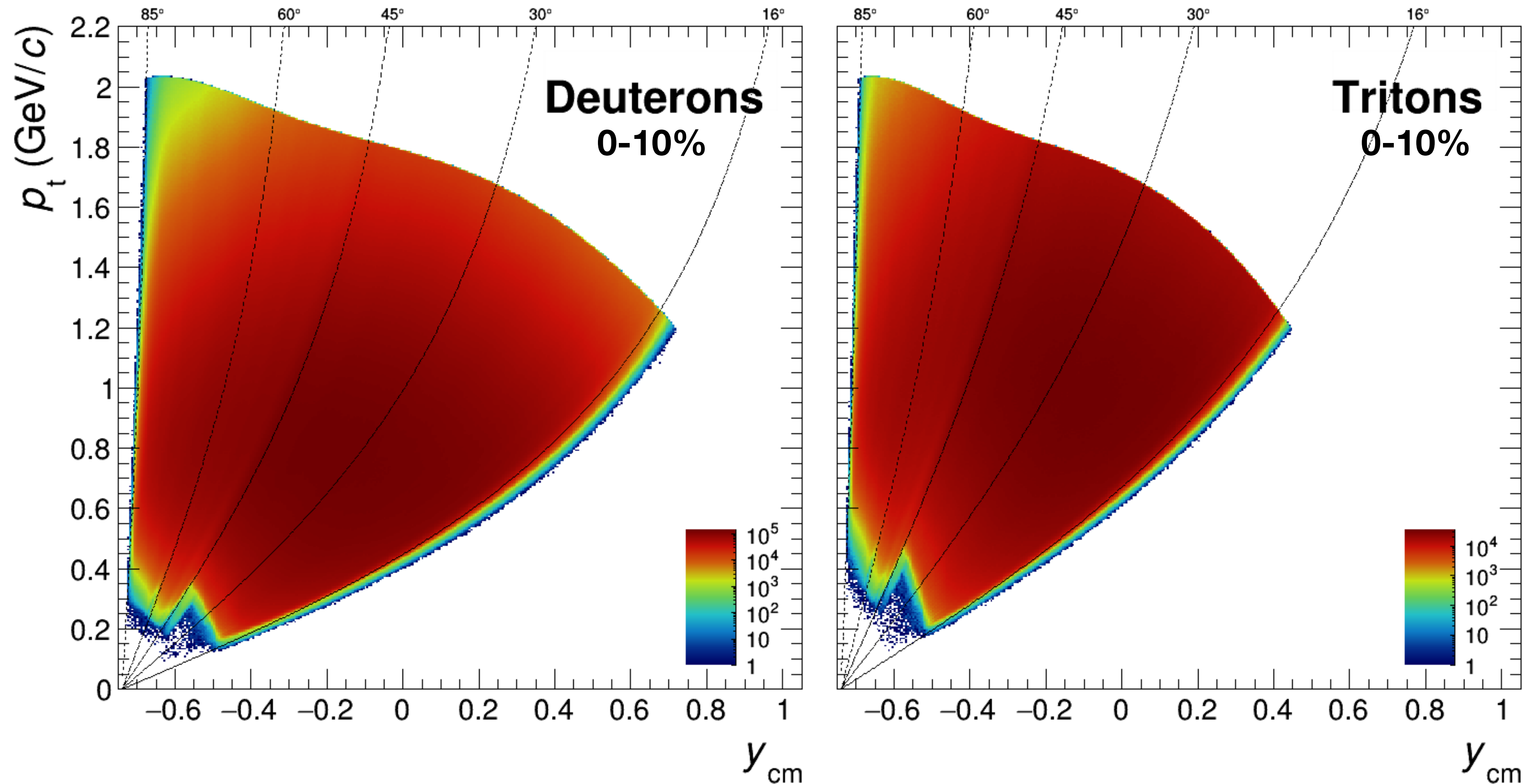

Radial Flow

Transverse Momentum Spectra

Blast-Wave model:

Phys. Rev. C **48**, 2462

$$\frac{dN}{p_T dp_T} \propto \int_0^R r dr m_T I_0 \left(\frac{p_T \sinh \rho(r)}{T_{kin}} \right) \times K_1 \left(\frac{m_T \cosh \rho(r)}{T_{kin}} \right)$$

Linear radial flow velocity profile: $\beta = \beta_S (r/R)^n \quad n = 1$

- Reasonable description of protons, light nuclei, kaons and pions (at higher m_t)

$$T_{kin} = 66 \pm 8 \text{ MeV}$$

$$\langle \beta_r \rangle = 0.34 \pm 0.04$$

$$T_{chem} = 68 \pm 2(\text{stat.}) \text{ MeV}$$

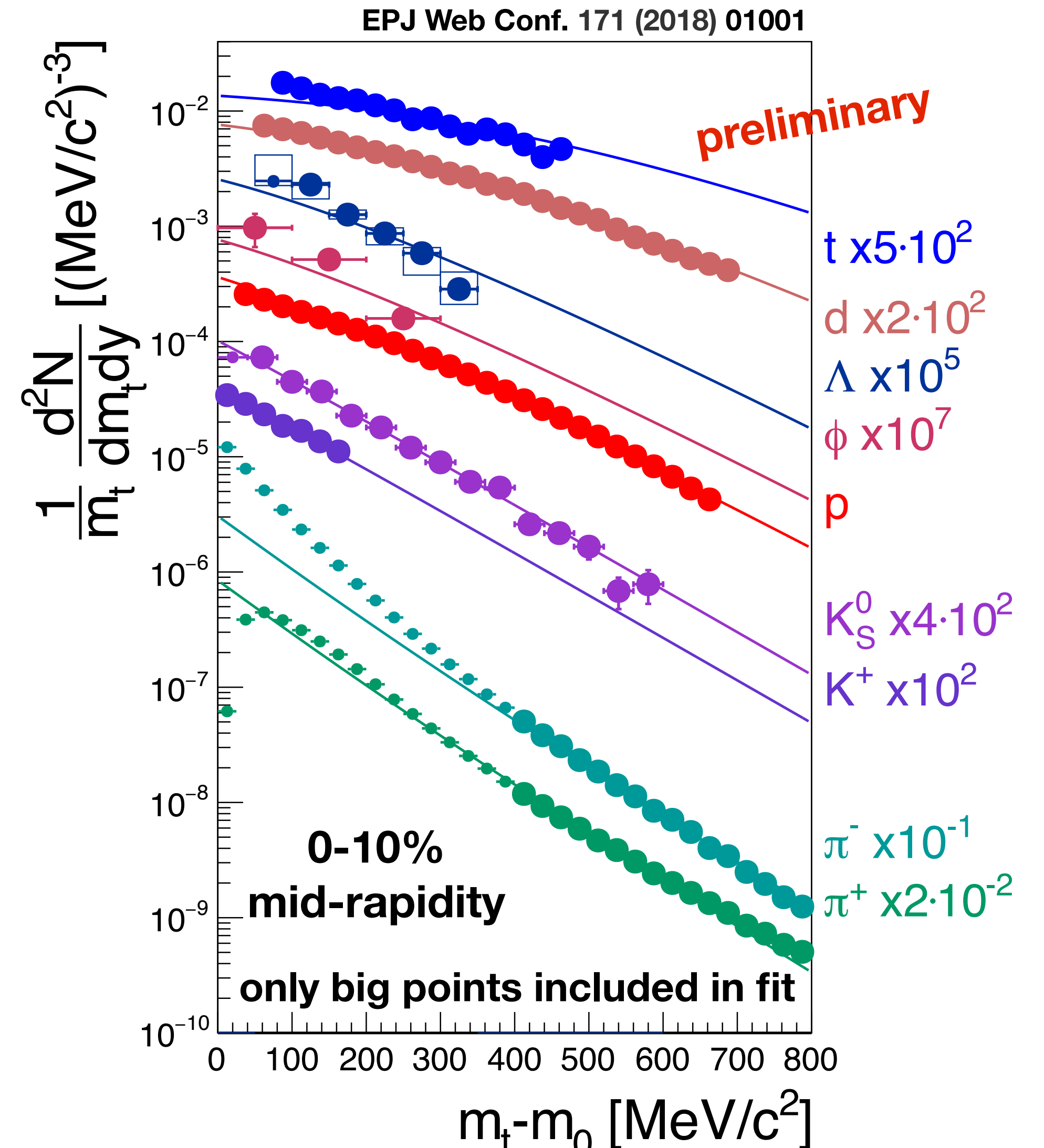

Radial Flow

Energy Dependence of Freeze-out Parameters

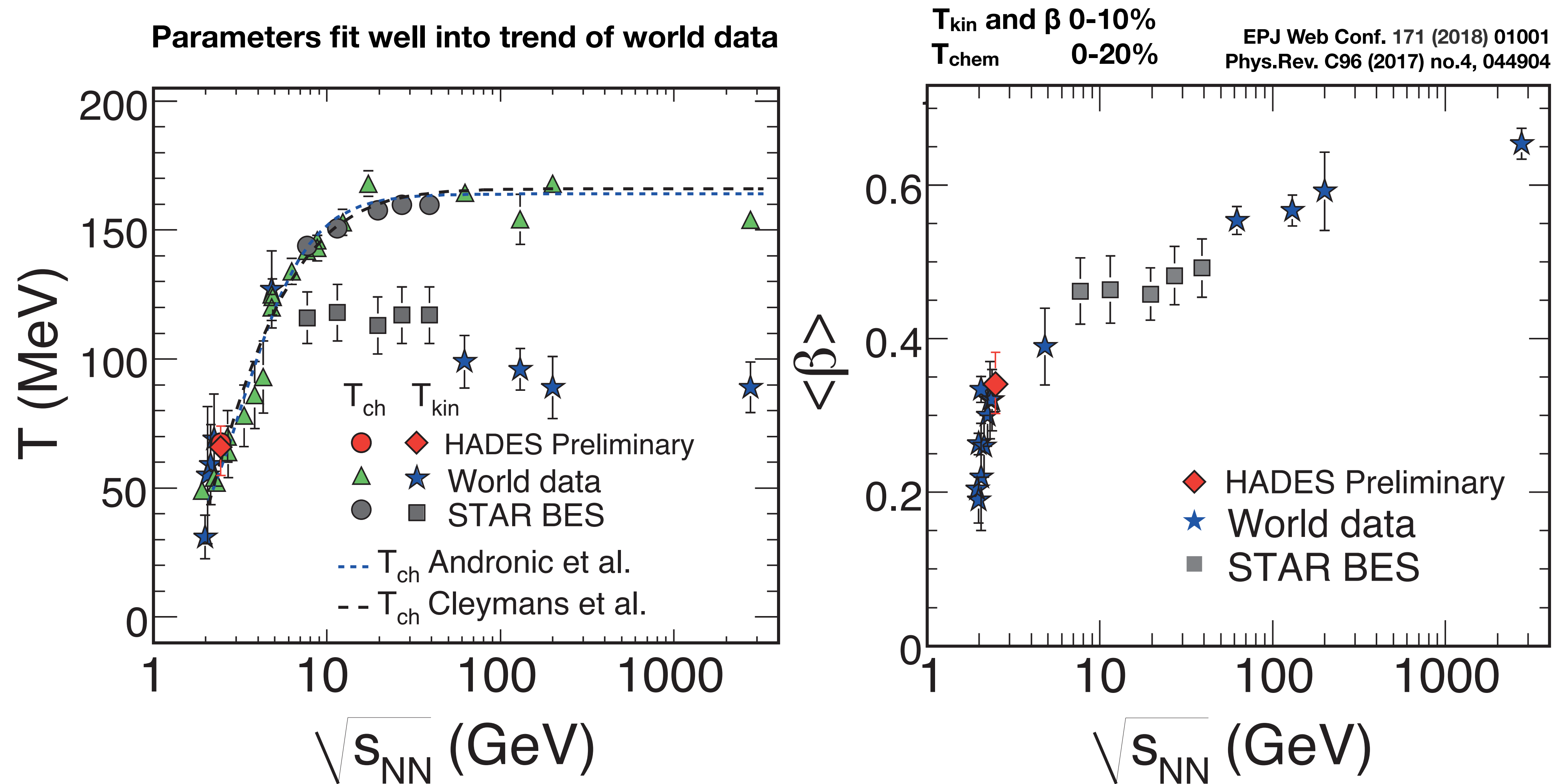

Radial Flow

HBT - Intensity Interferometry

- First measurement of pion HBT in Au+Au collisions at 1.23 AGeV
- R_{side} : smaller radii for higher pair transverse momenta:

→ **Radial flow**

- Accounting for Coulomb potential

→ **First time such substantial difference!**

m_T : transverse mass of the pair

$$m_T = \sqrt{k_t^2 + m_0^2}$$

arXiv:1811.06213

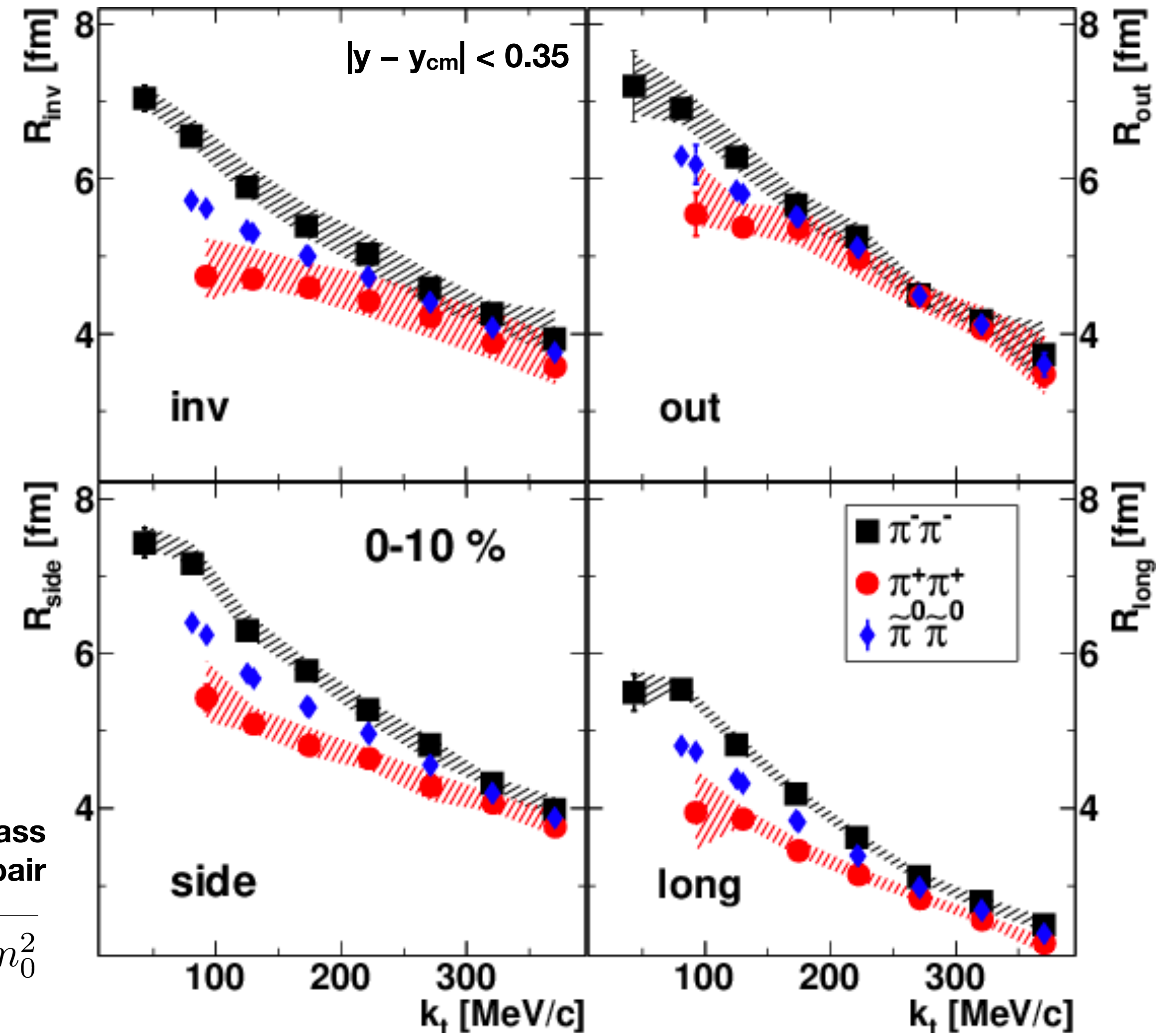

Radial Flow

HBT - Intensity Interferometry

arXiv:1811.06213

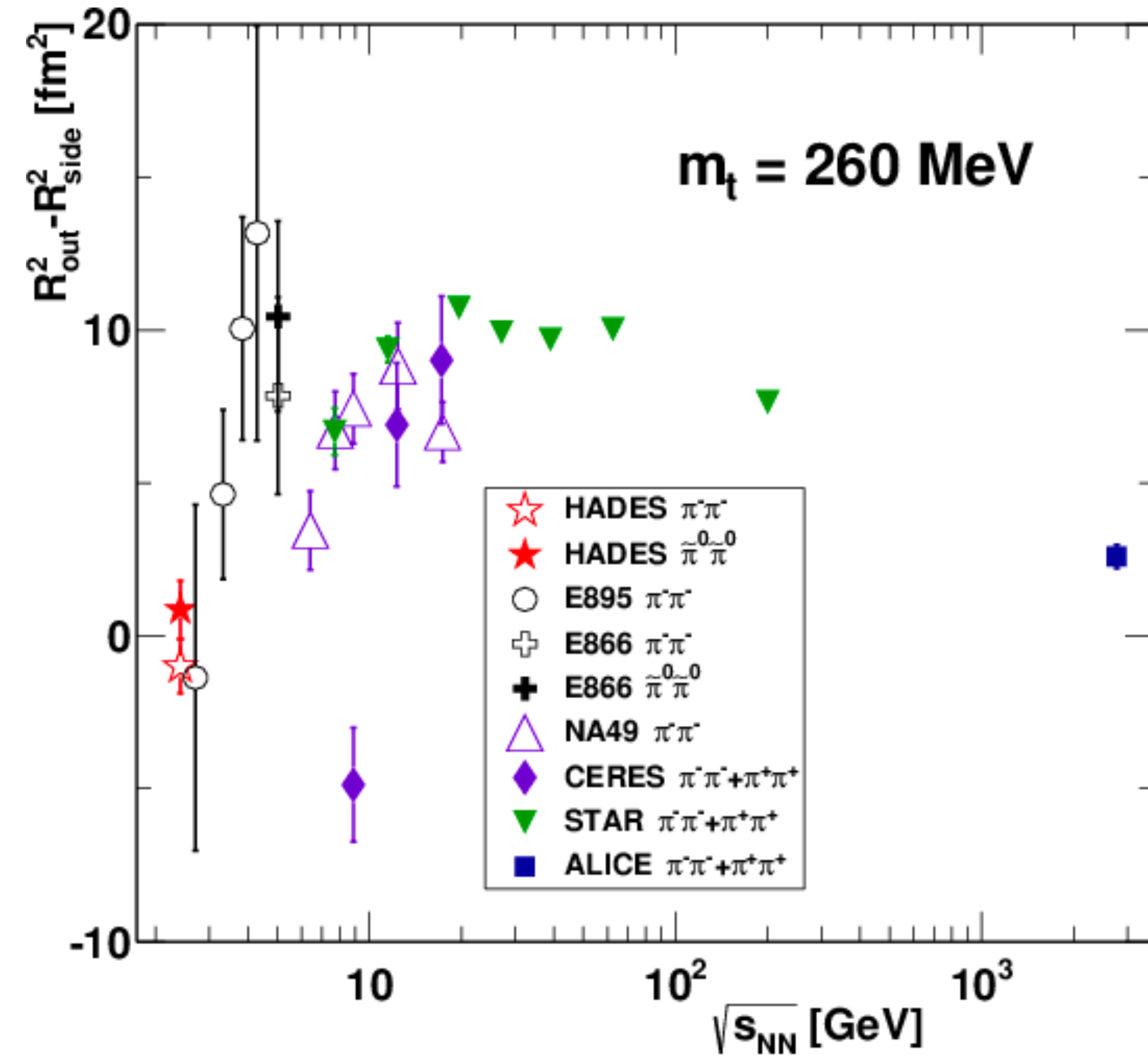
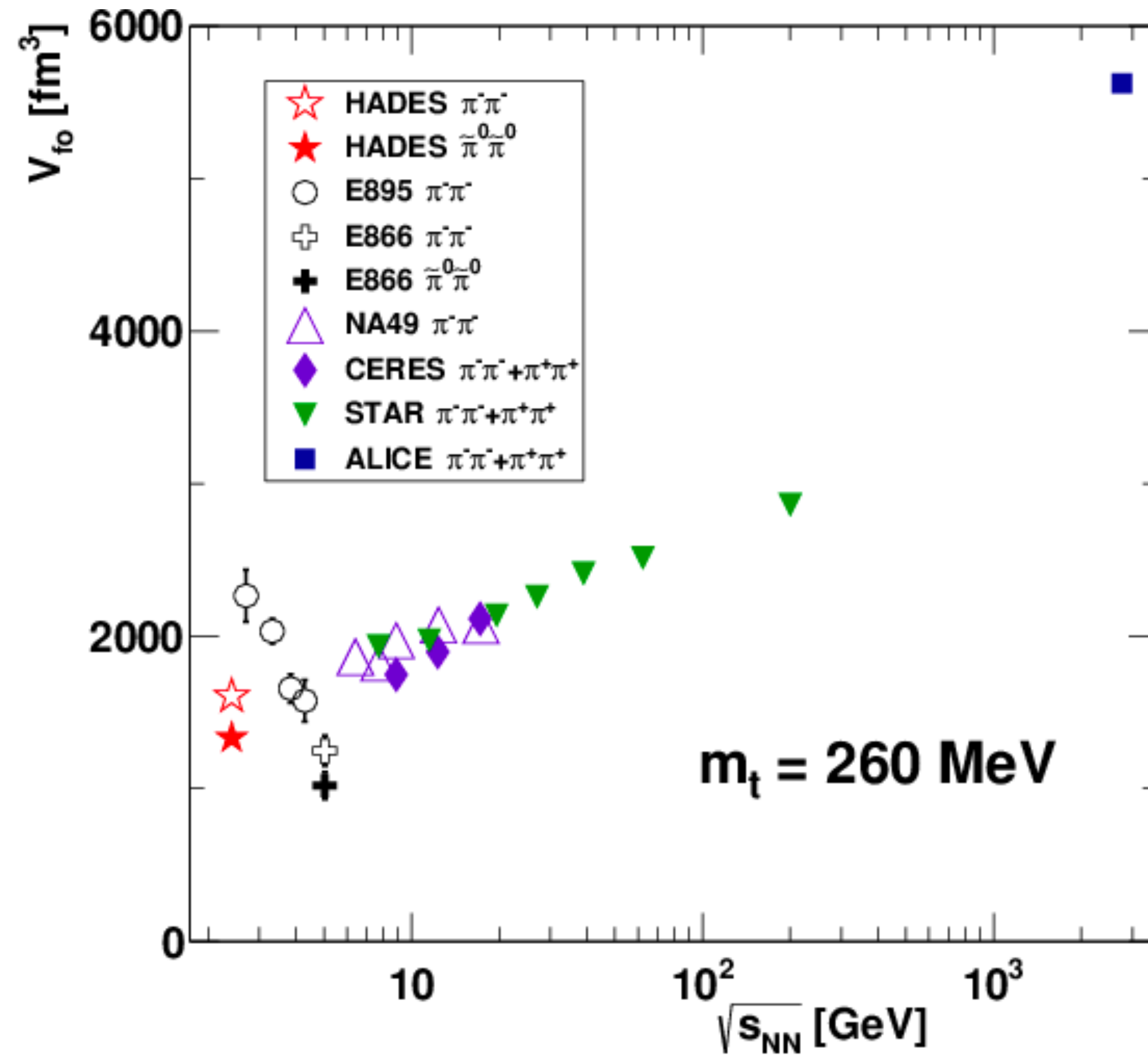

$$V_{fo} = (2\pi)^{3/2} R_{side}^2 R_{long} \approx 1300 \text{ fm}^3$$

Directed Flow v_1 : Protons

p_t -Dependence

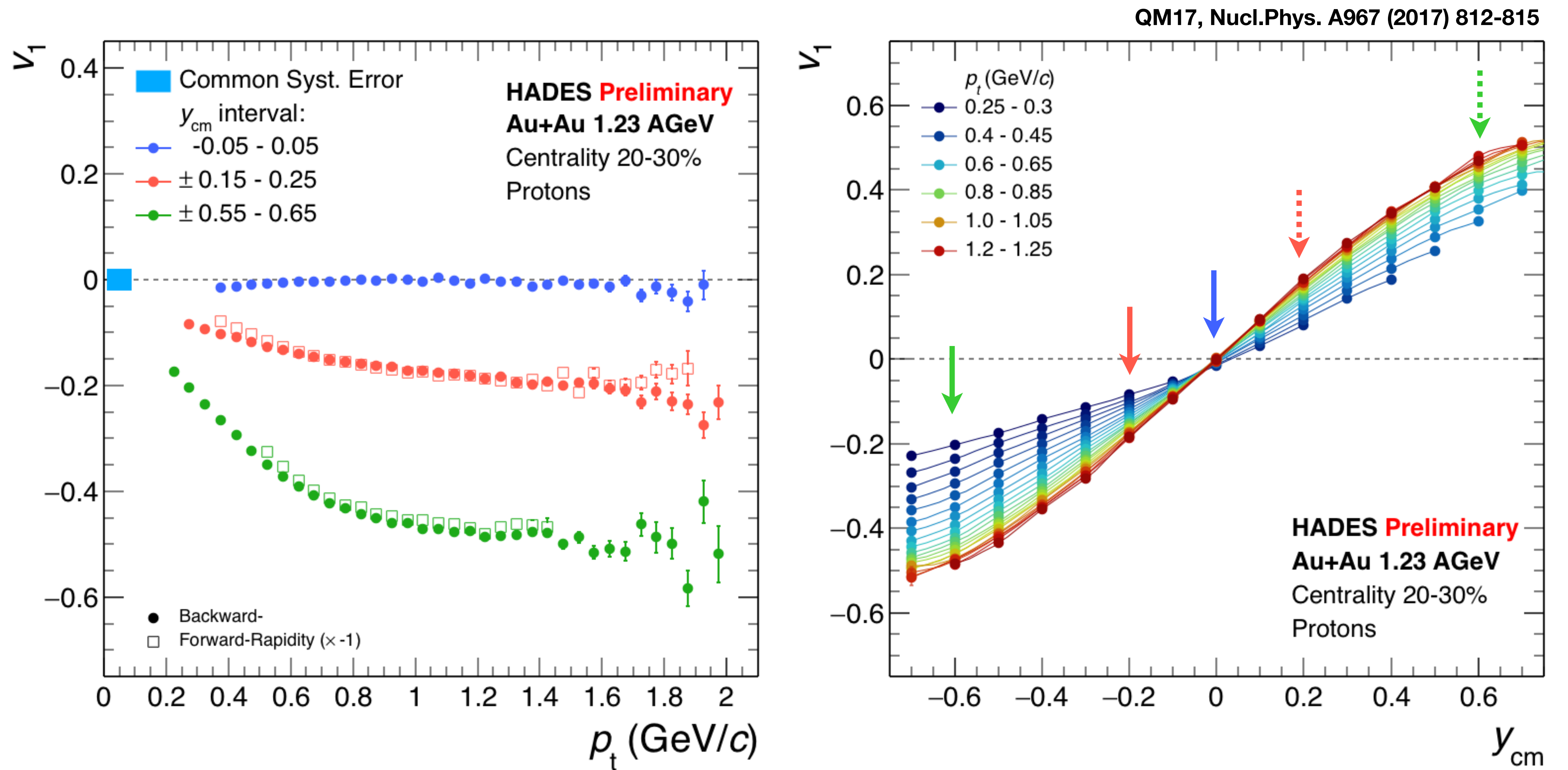

Good agreement between backward and forward rapidity bins

Directed Flow v_1 : Deuterons

p_t -Dependence

QM18, Nucl.Phys. A982 (2019) 431

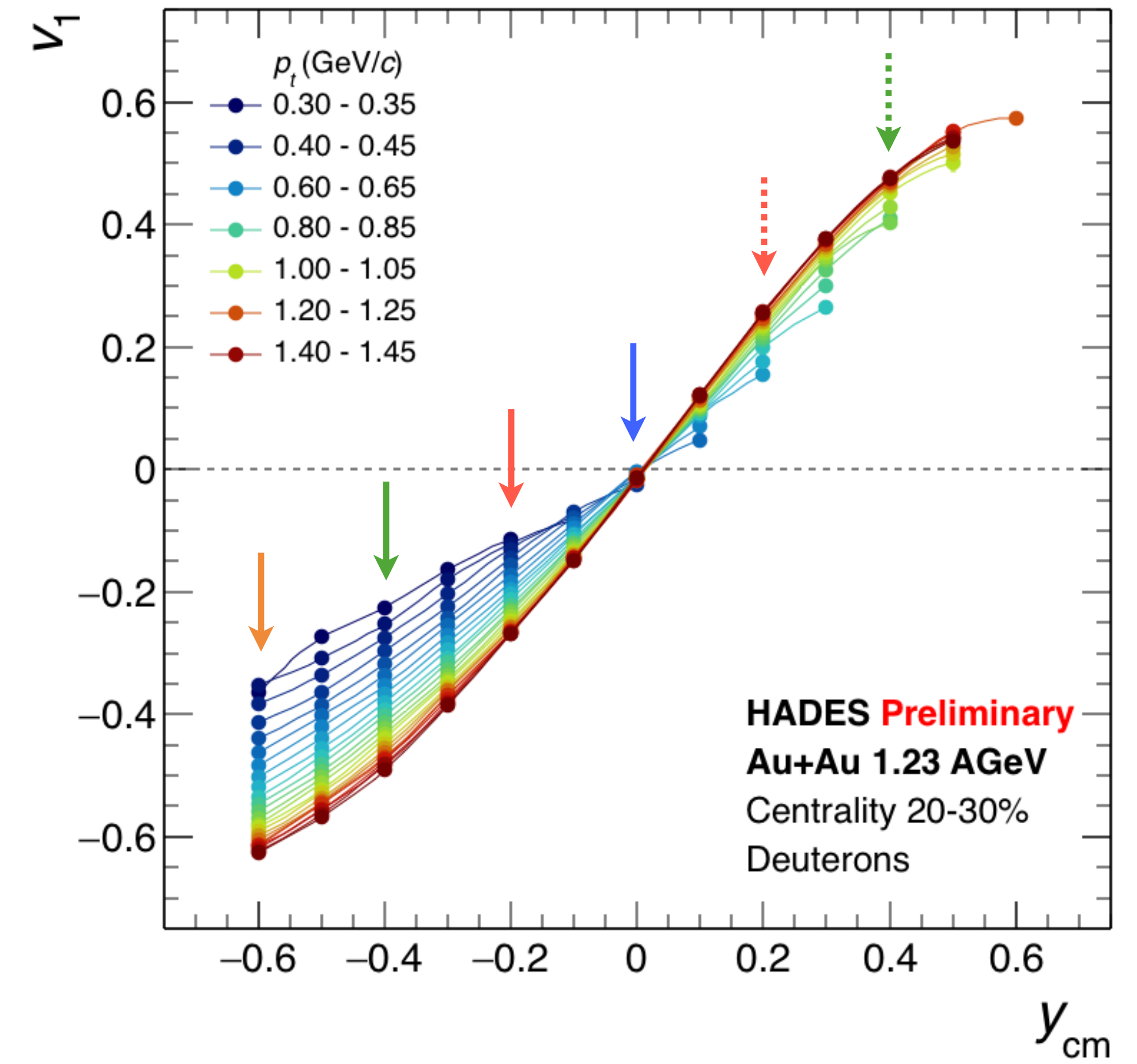
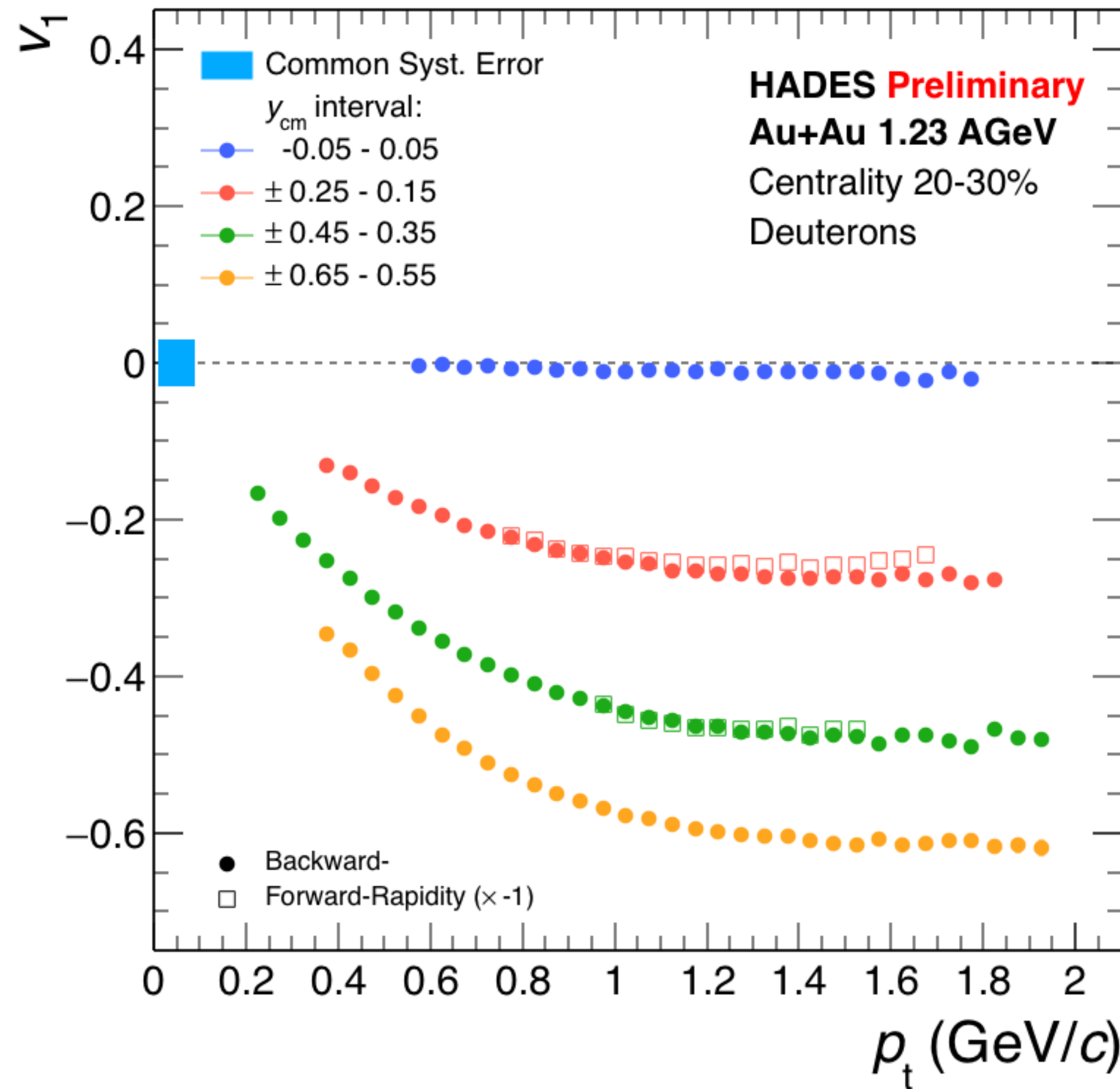

Good agreement between backward and forward rapidity bins

Directed Flow v_1 : Tritons

p_t -Dependence

QM18, Nucl.Phys. A982 (2019) 431

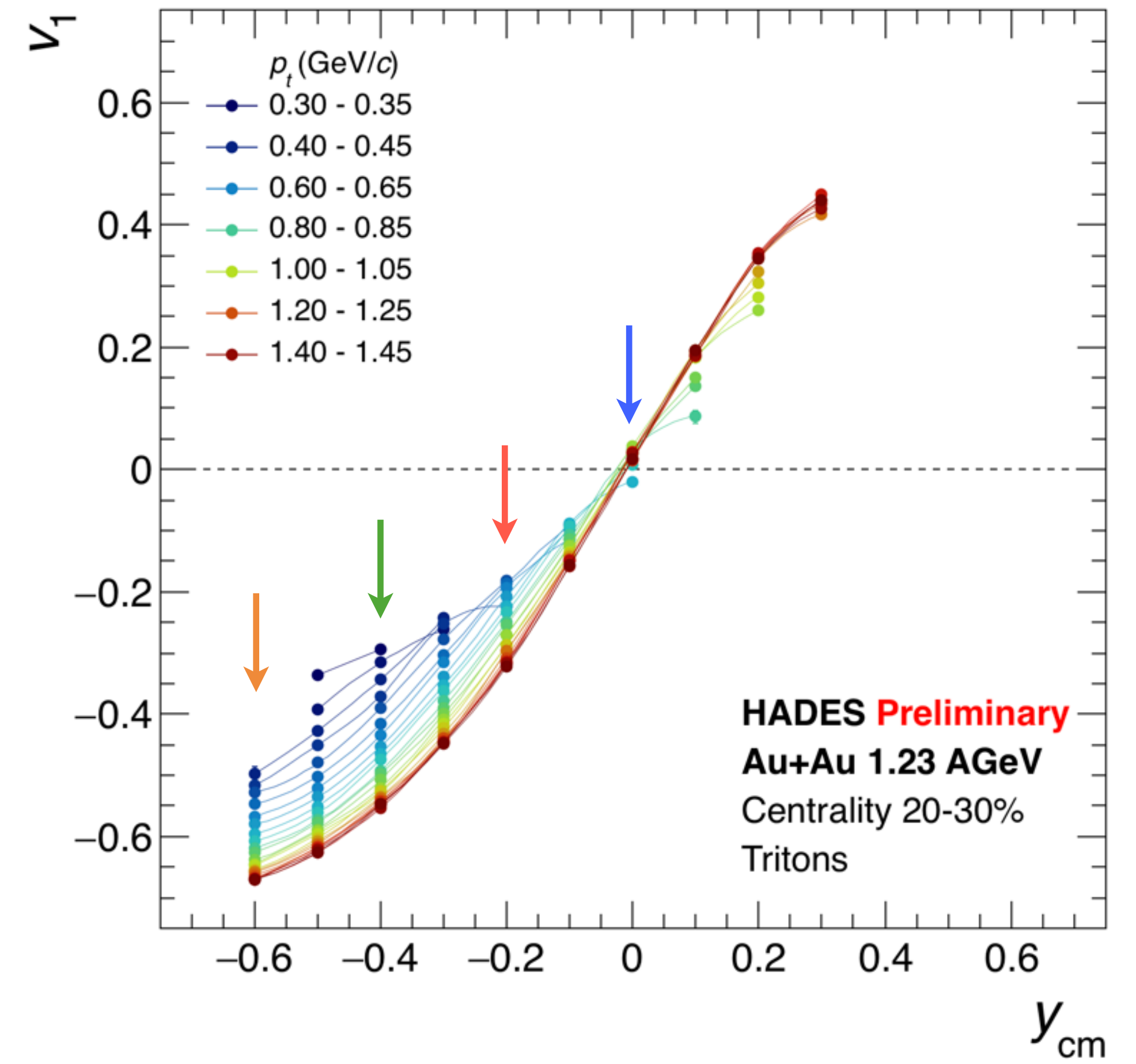
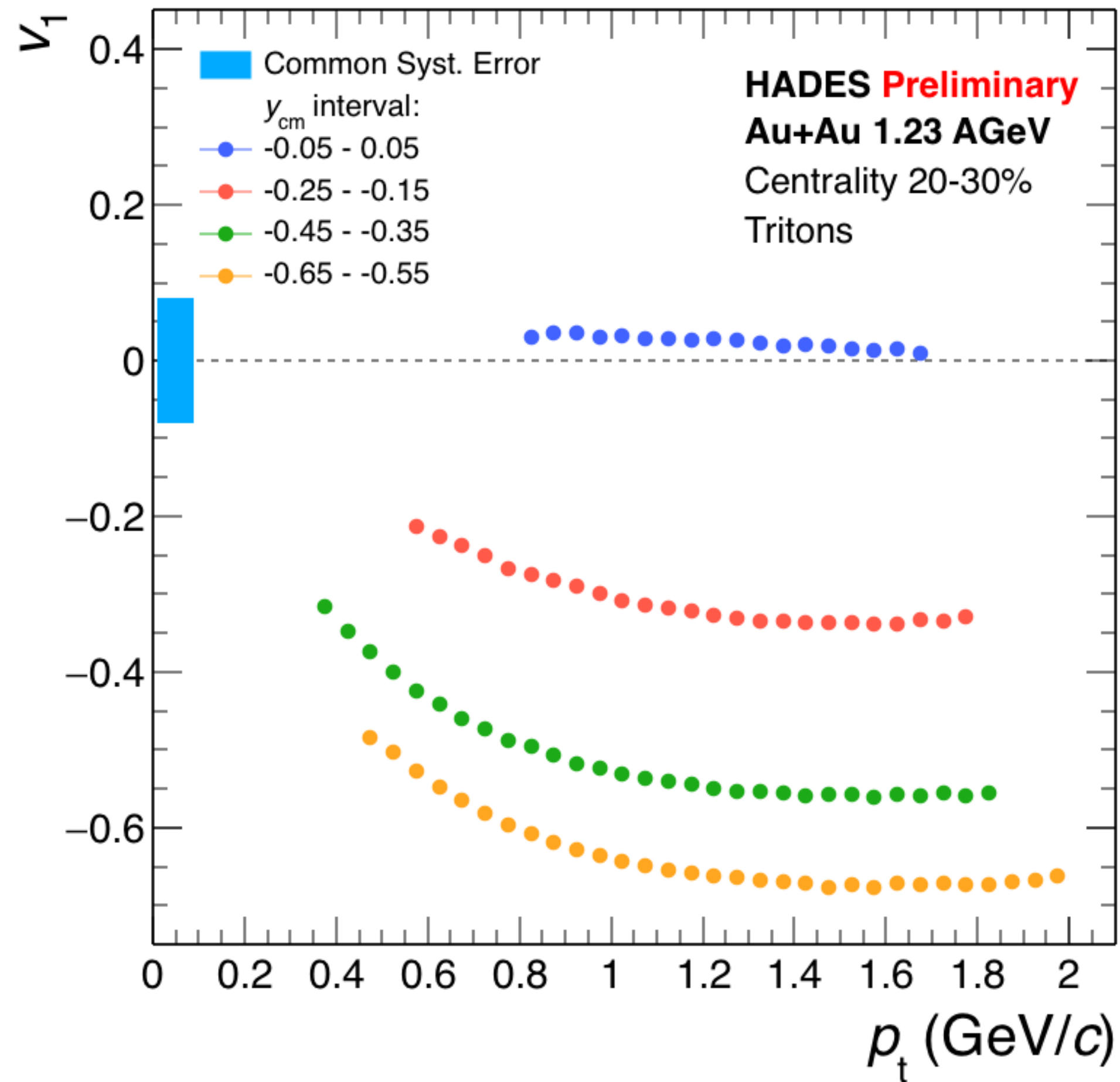

Elliptic Flow v_2 : Proton

p_t -Dependence

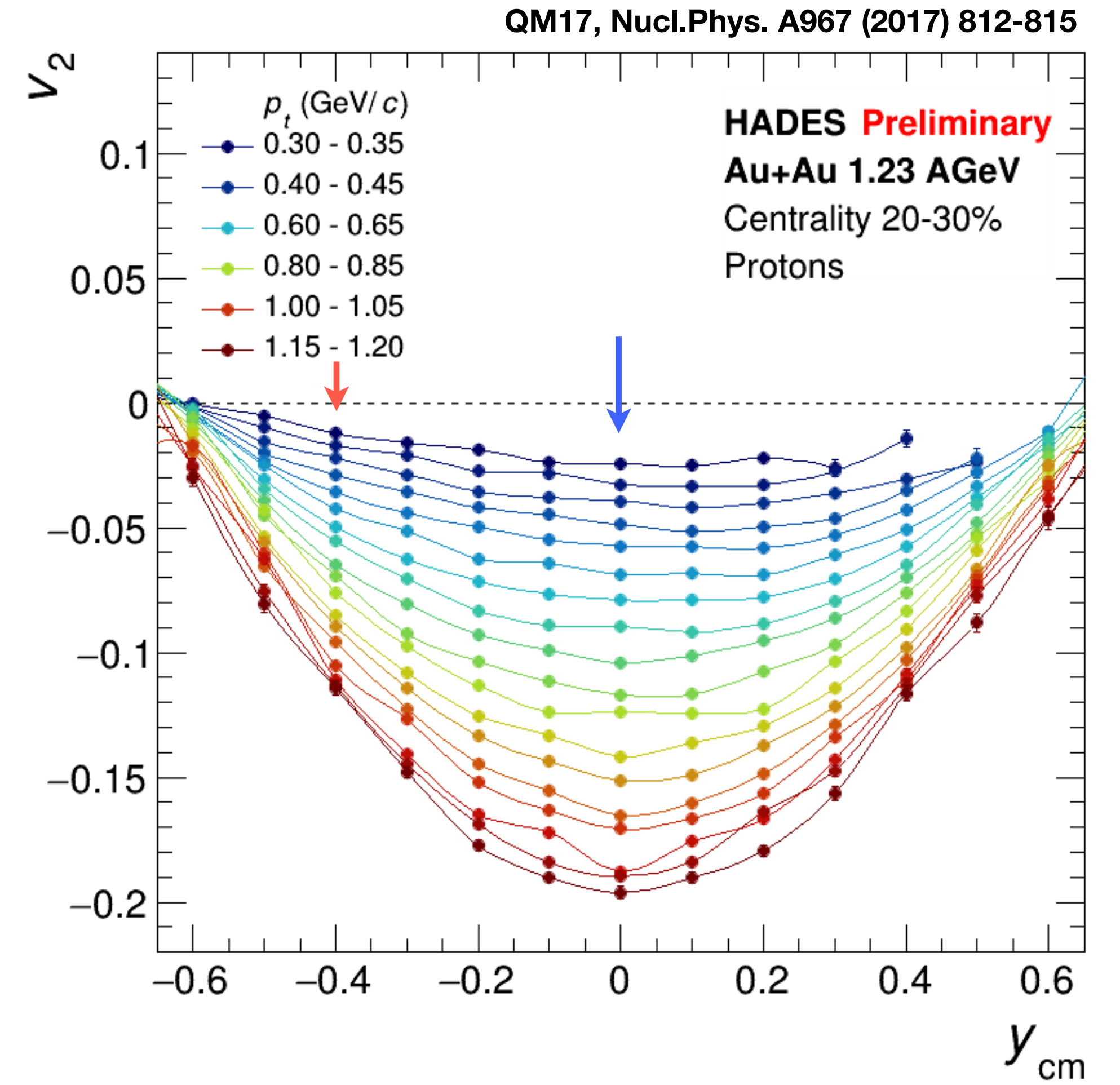
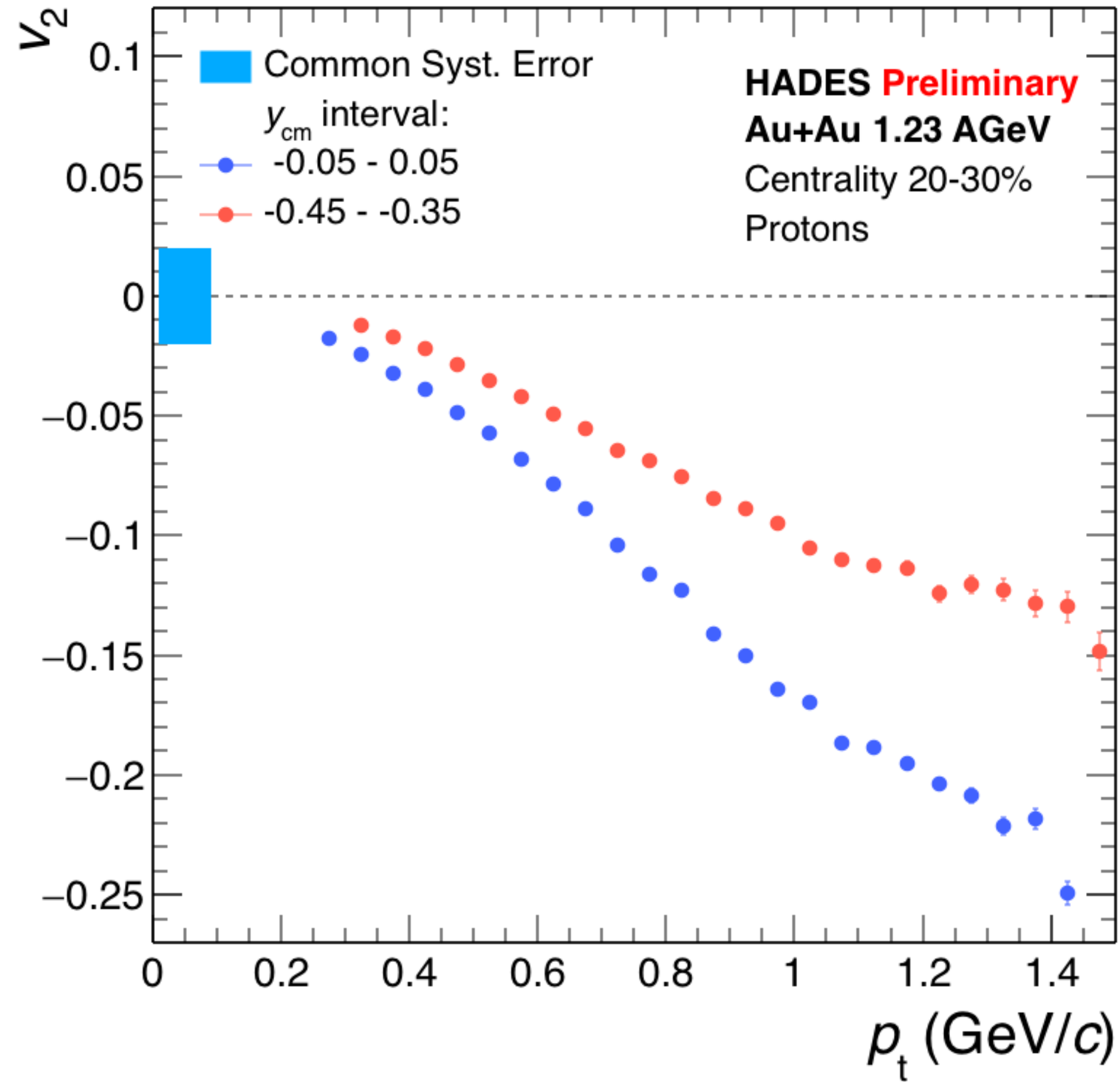

Elliptic Flow v_2 : Deuterons

p_t -Dependence

QM18, Nucl.Phys. A982 (2019) 431

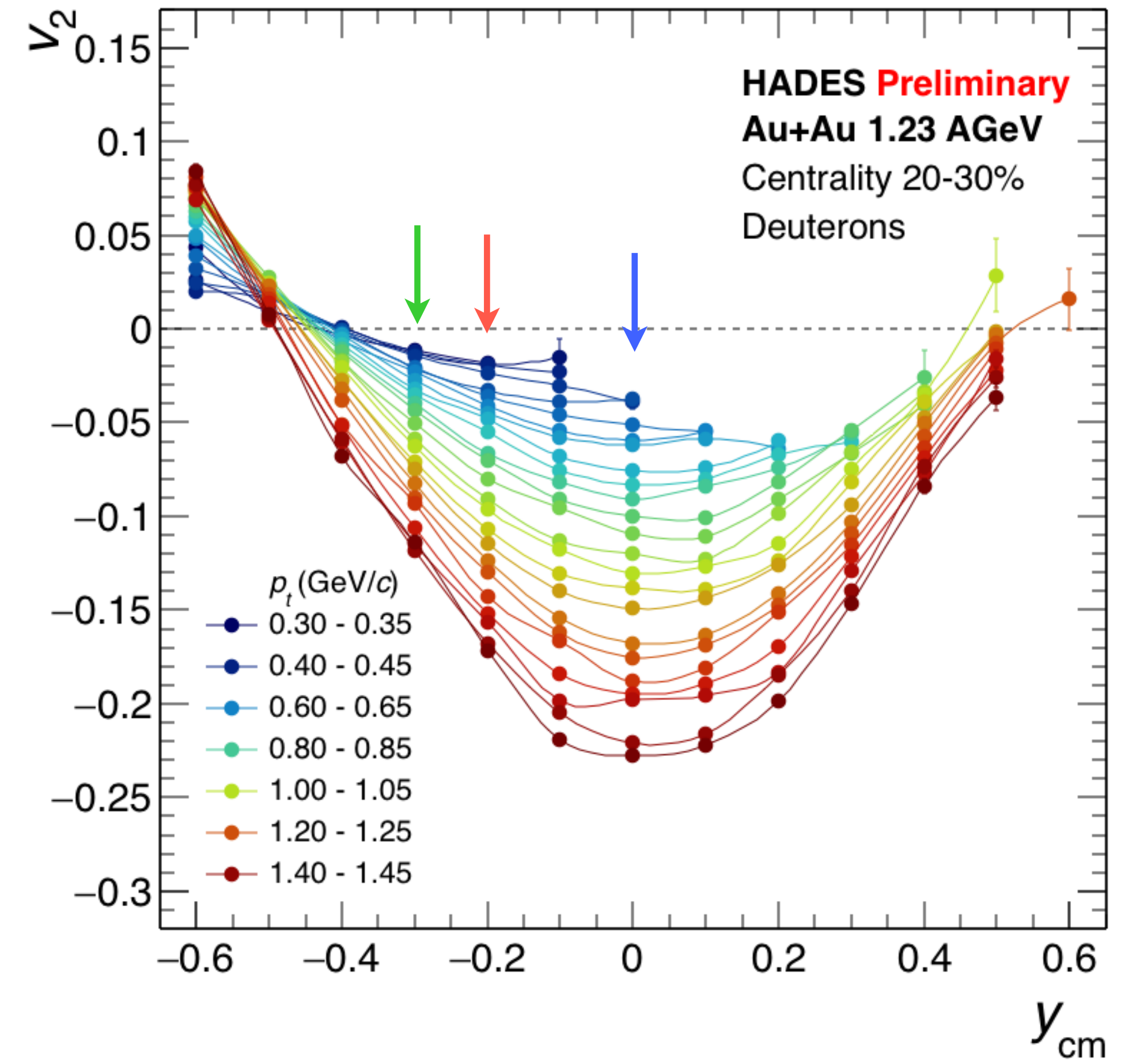
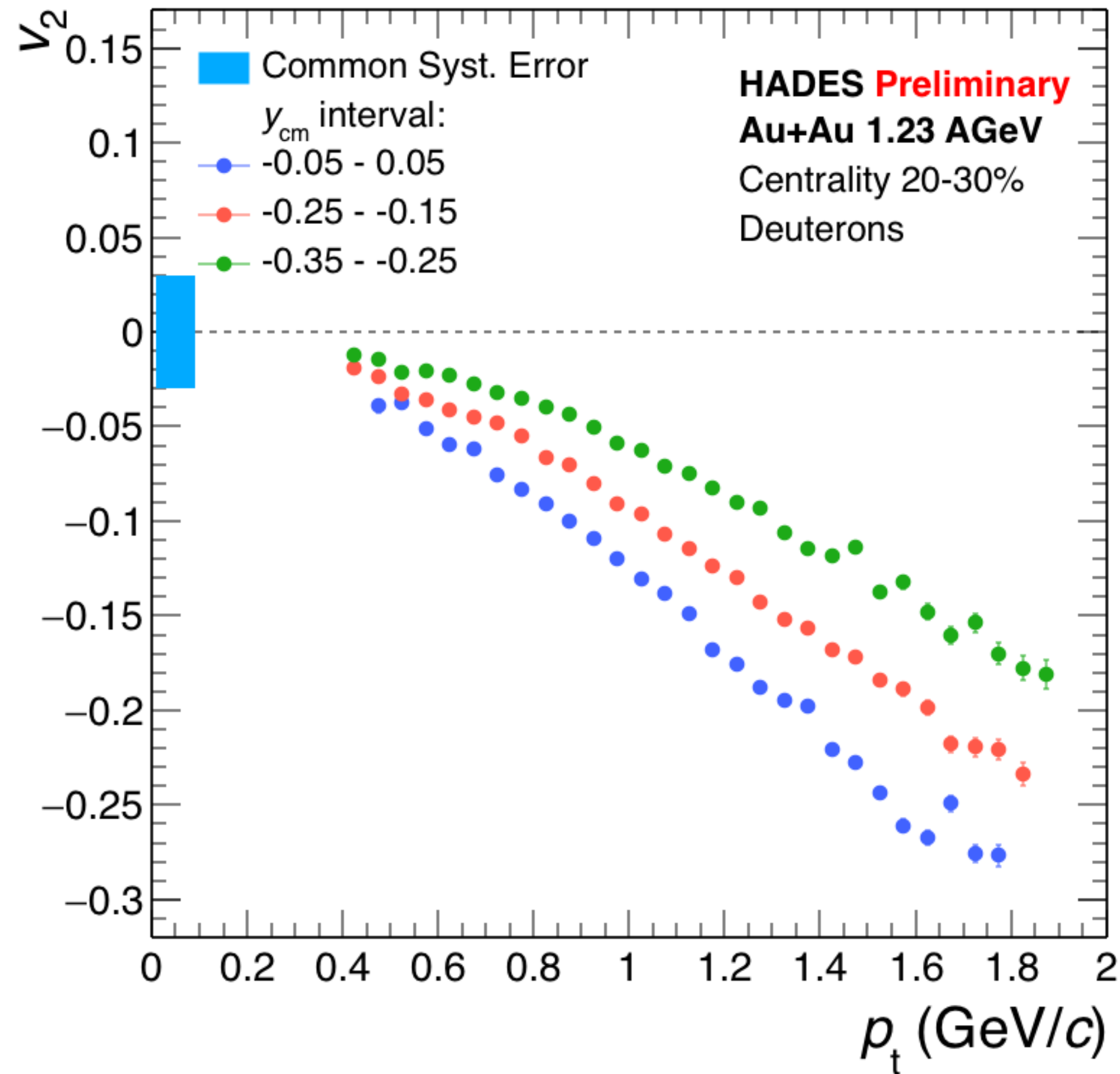

Elliptic Flow v_2 : Tritons

p_t -Dependence

QM18, Nucl.Phys. A982 (2019) 431

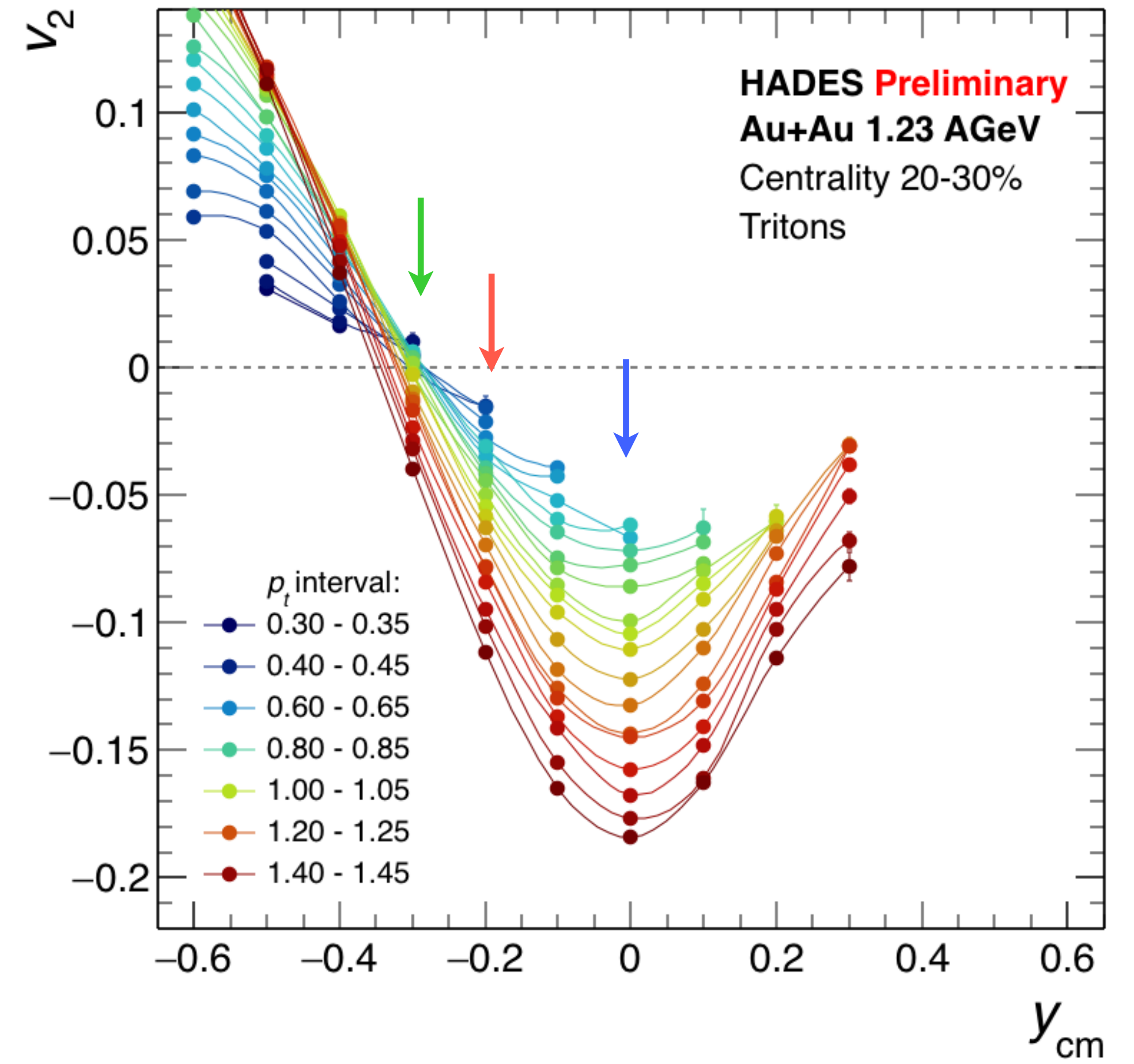
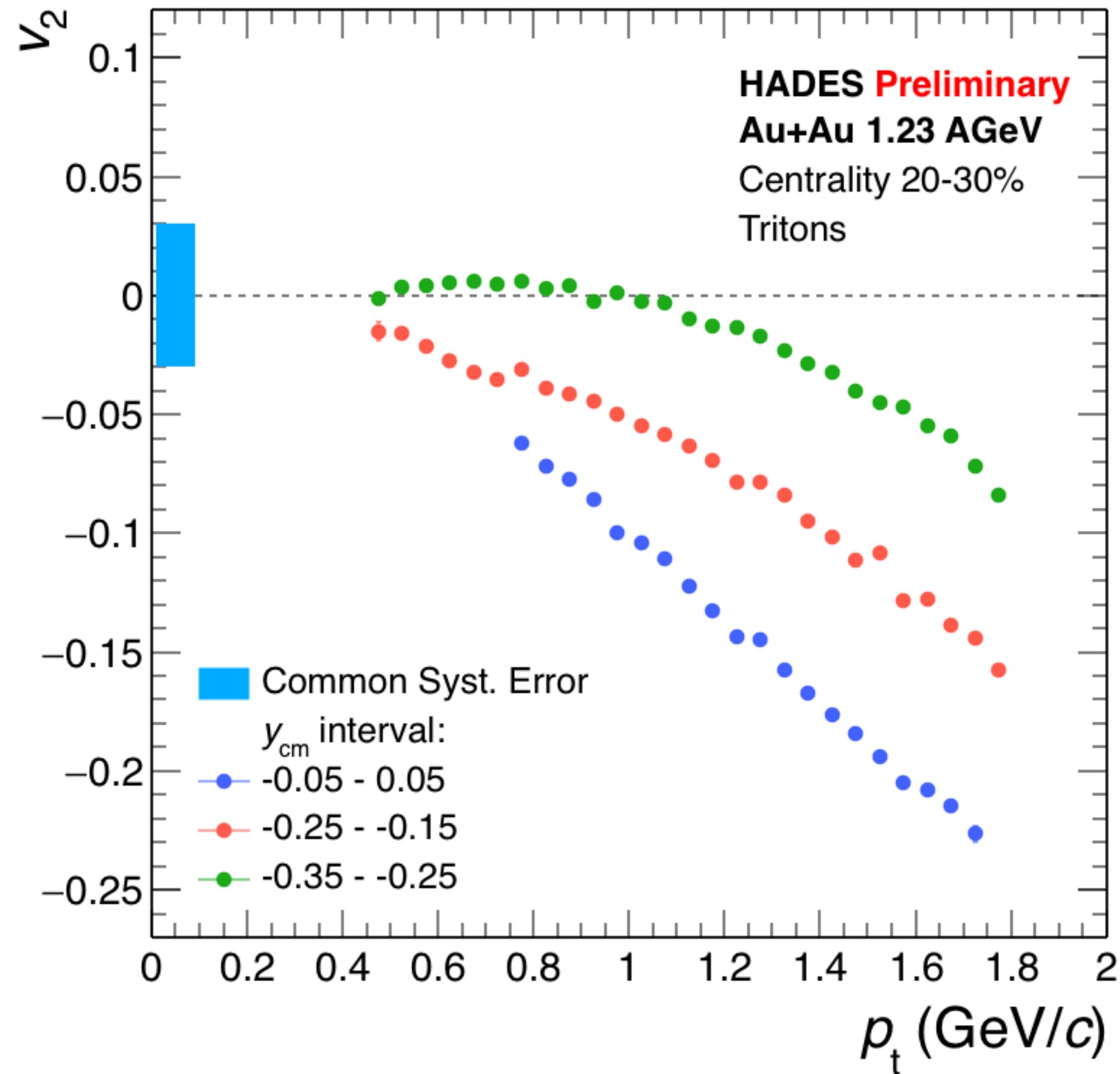

Elliptic Flow v_2 : Light Nuclei

Nucleon Coalescence

- Comparison of p, d, t v_2 at mid-rapidity

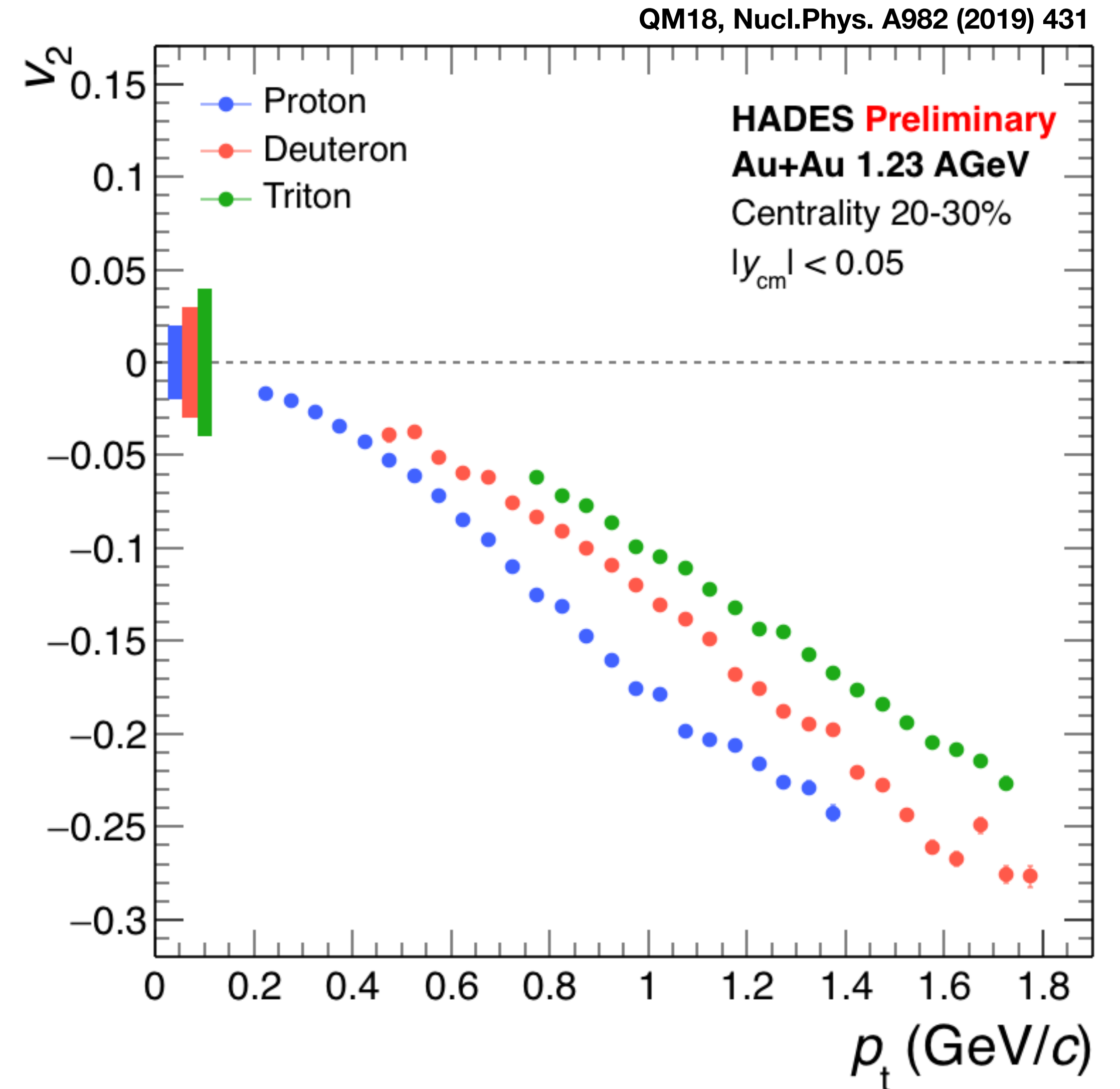

Elliptic Flow v_2 : Light Nuclei

Nucleon Coalescence

- Comparison of p, d, t v_2 at mid-rapidity
- Scaling of v_2 and p_t with nuclear mass number A
- As expected for nucleon coalescence

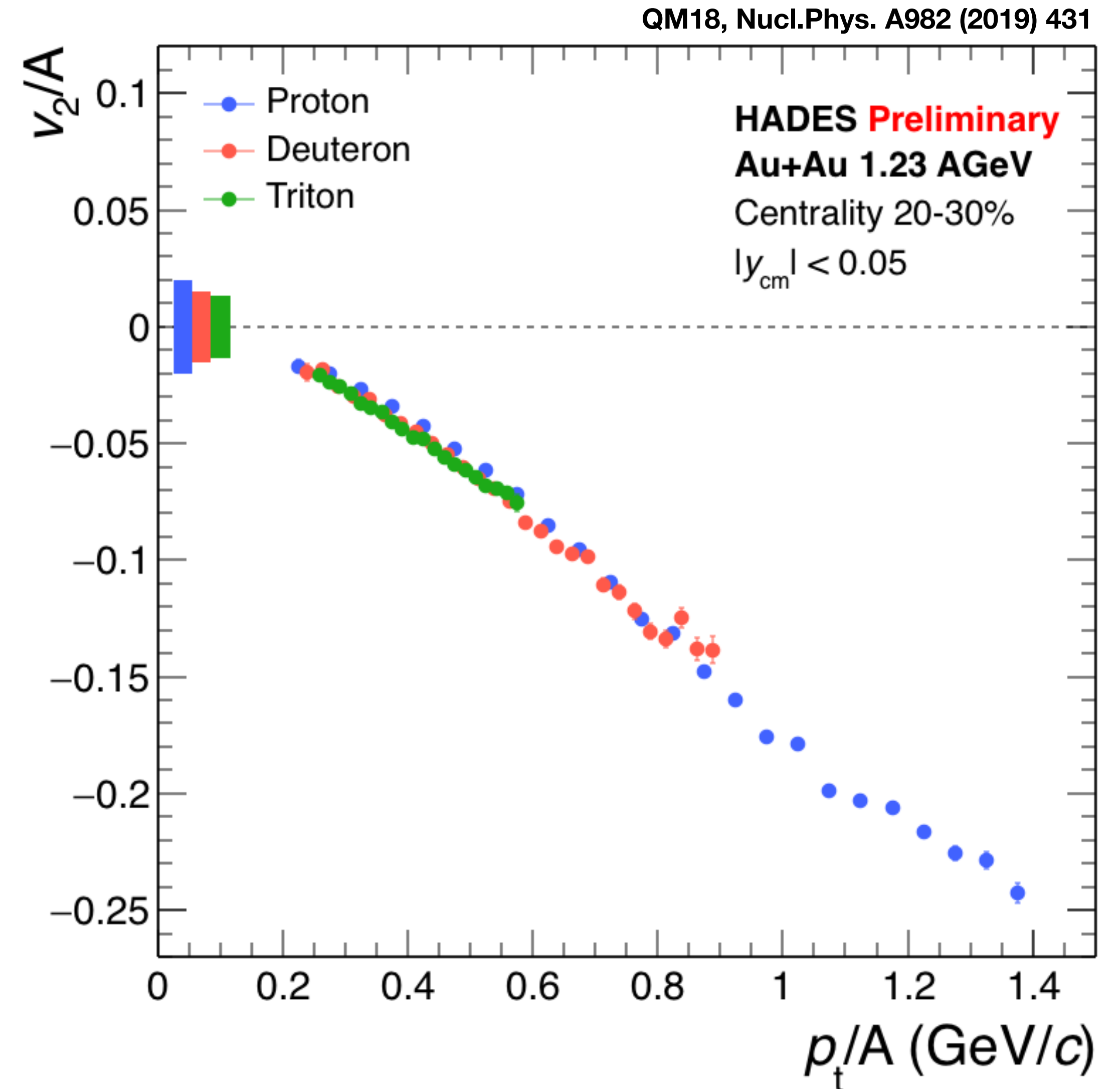

Triangular Flow $v_3\{\Psi_{RP}\}$

Protons and Light Nuclei

QM18, Nucl.Phys. A982 (2019) 431

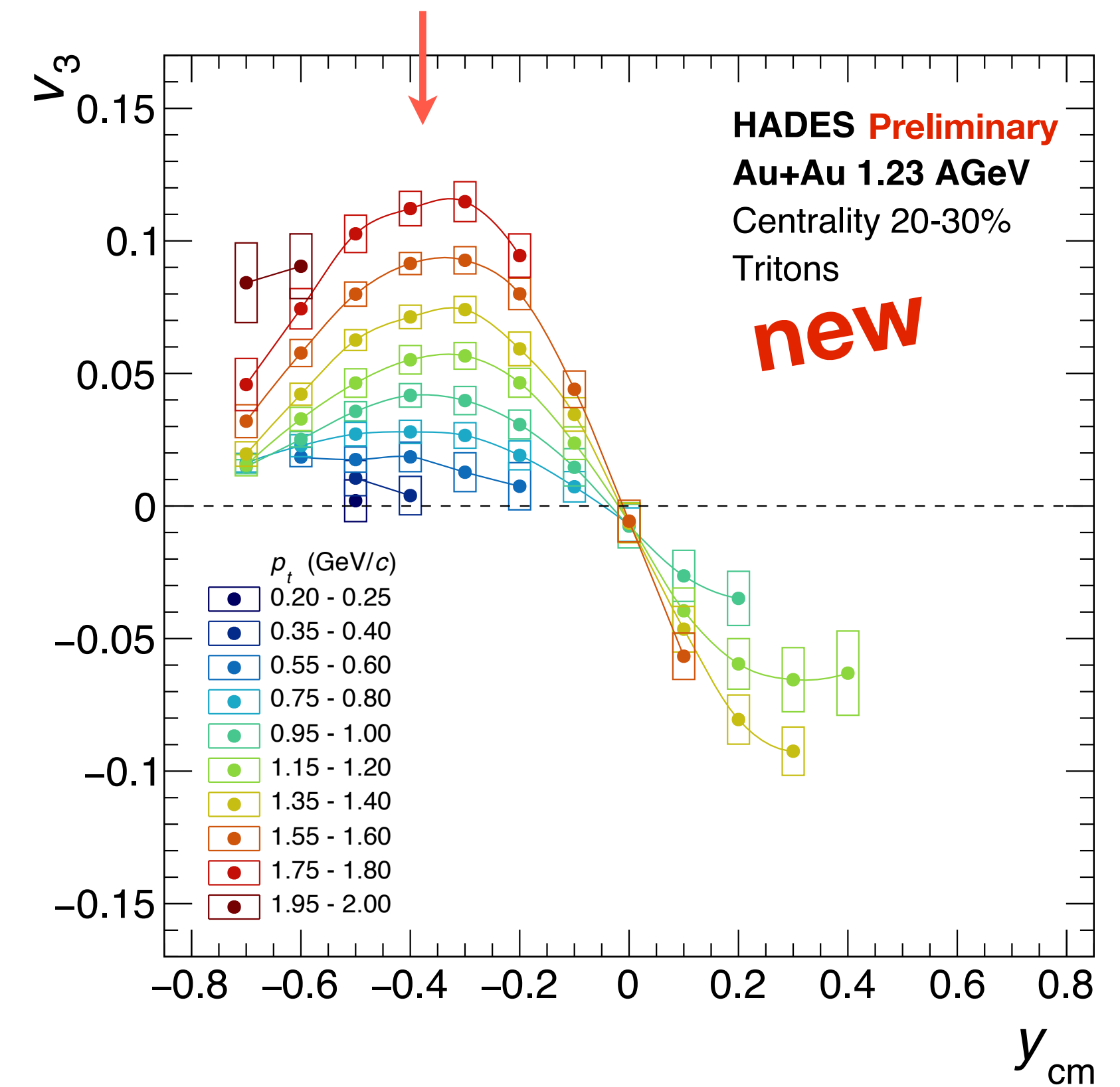
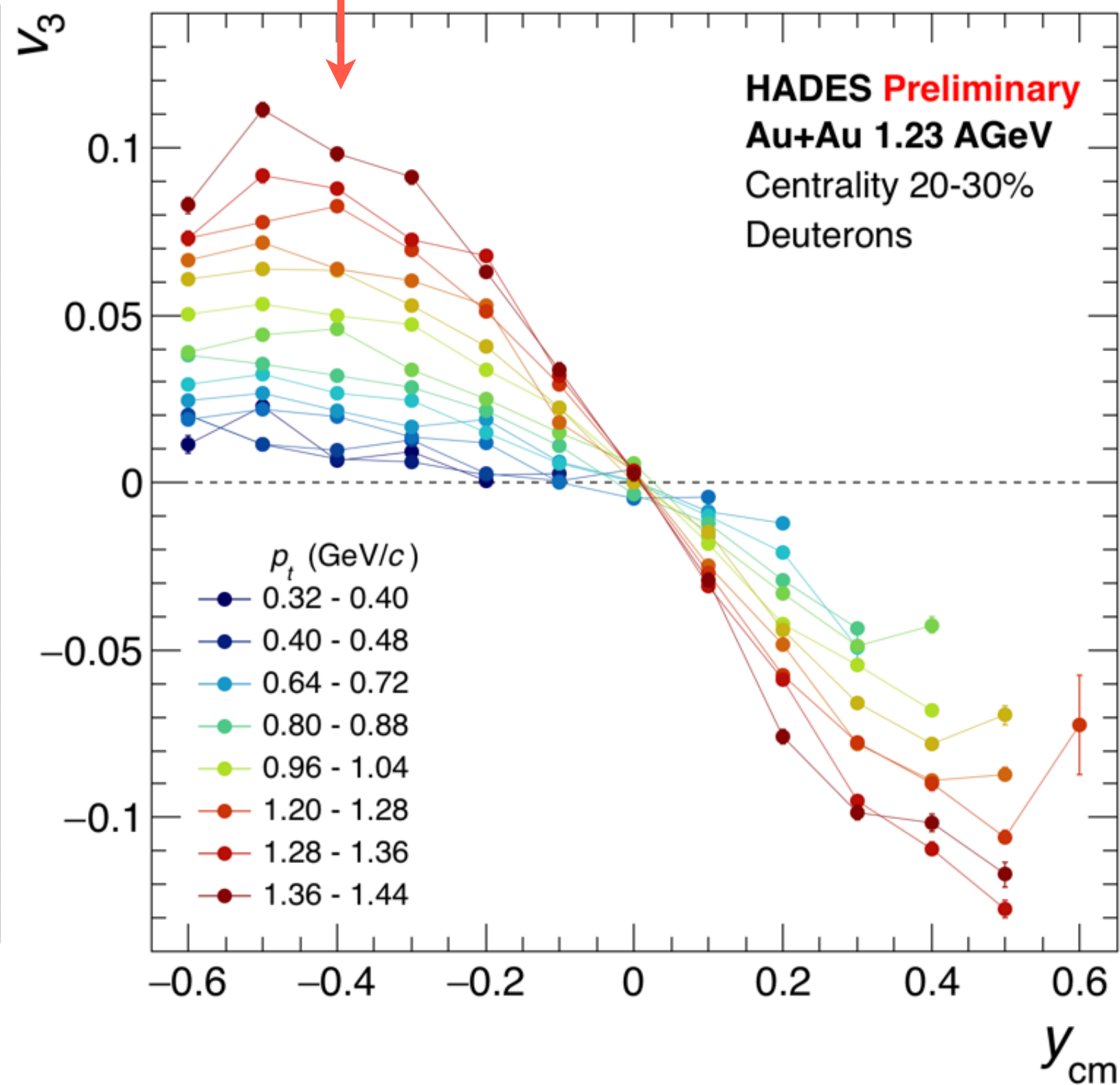
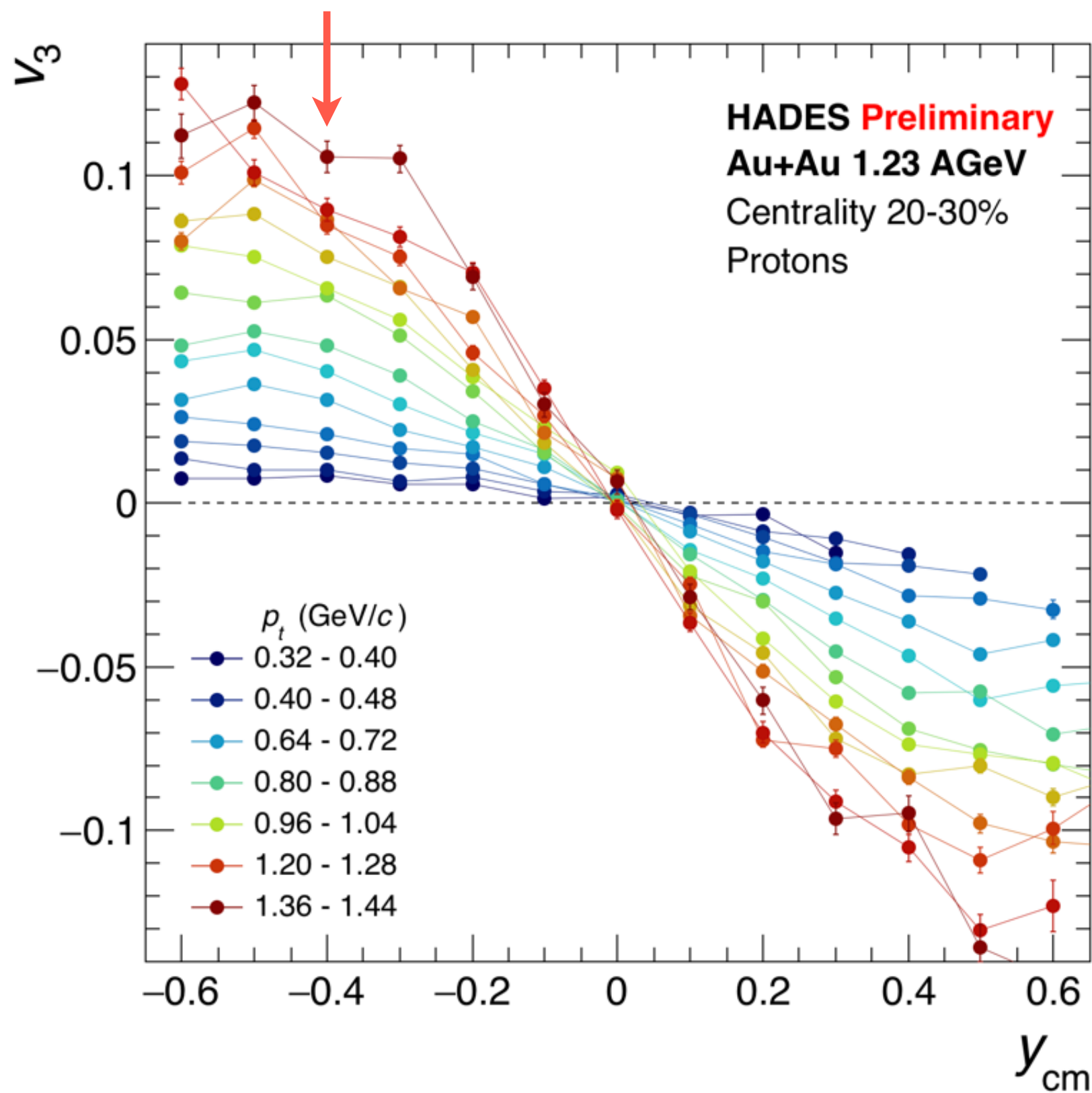

Note: $v_3\{\Psi_{RP}\}$ w.r.t reaction plane

$$v_3\{\Psi_{RP}\} = \langle\langle \cos 3(\varphi - \Psi_{RP}) \rangle\rangle$$

Triangular Flow $v_3\{\Psi_{RP}\}$

Protons and Light Nuclei

QM18, Nucl.Phys. A982 (2019) 431

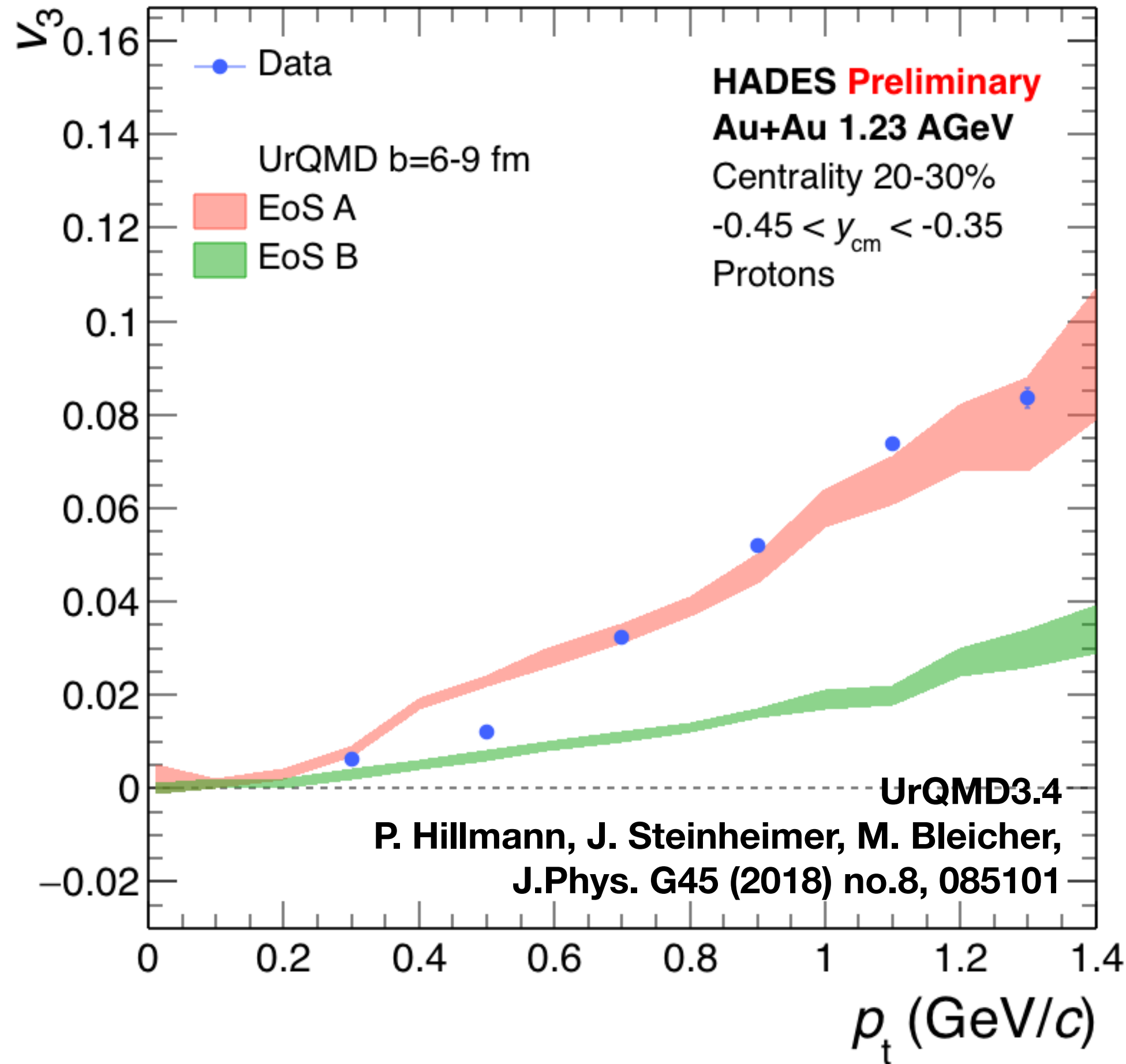

UrQMD predicts high sensitivity of v_3 to EoS

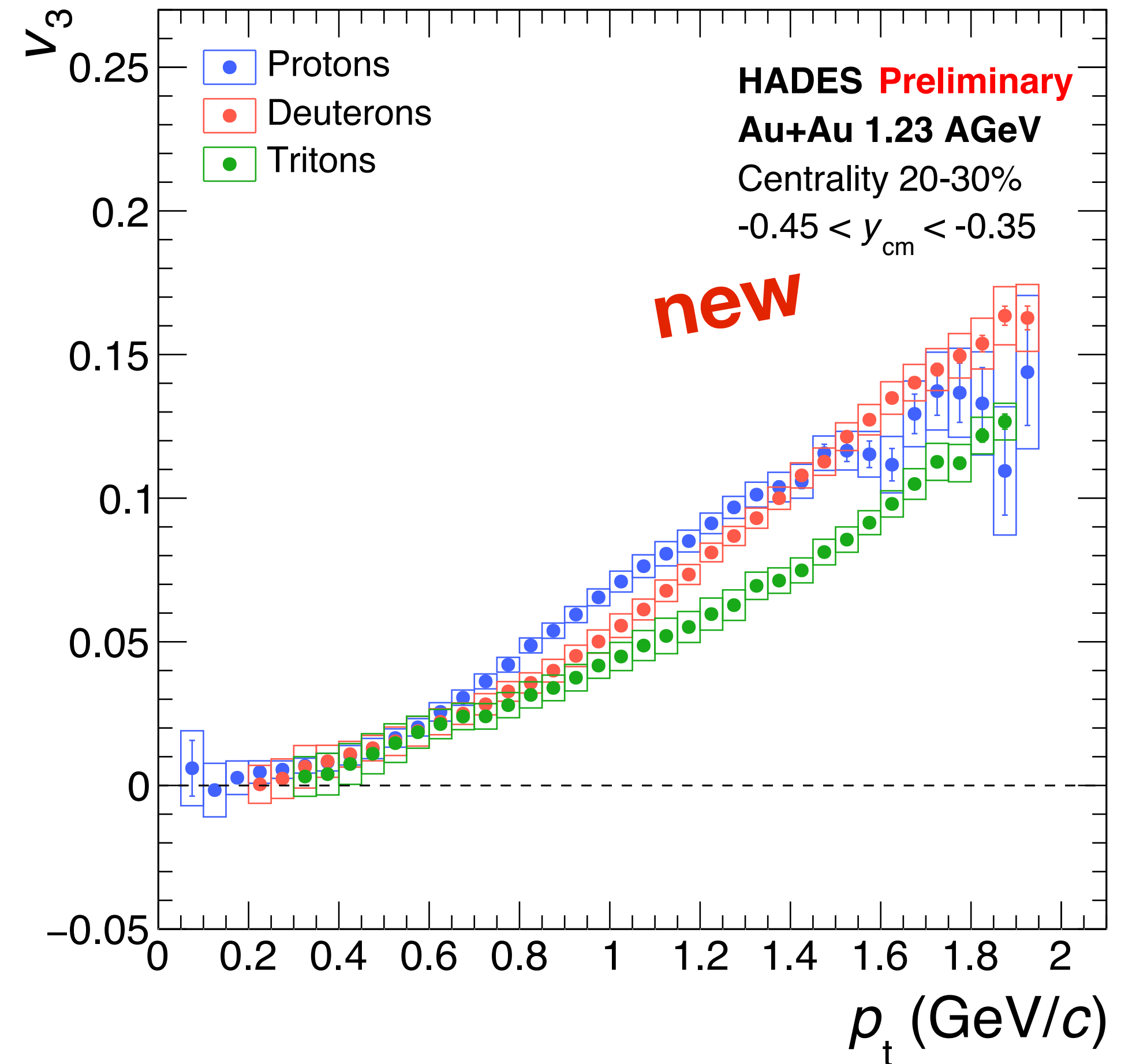

Note: $v_3\{\Psi_{RP}\}$ w.r.t reaction plane $v_3\{\Psi_{RP}\} = \langle\langle \cos 3(\varphi - \Psi_{RP}) \rangle\rangle$

Quadrangular Flow $v_4\{\Psi_{RP}\}$

Protons and Light Nuclei

- First measurement of quadrangular $v_4\{\Psi_{RP}\}$ of protons, deuterons and tritons at SIS energies

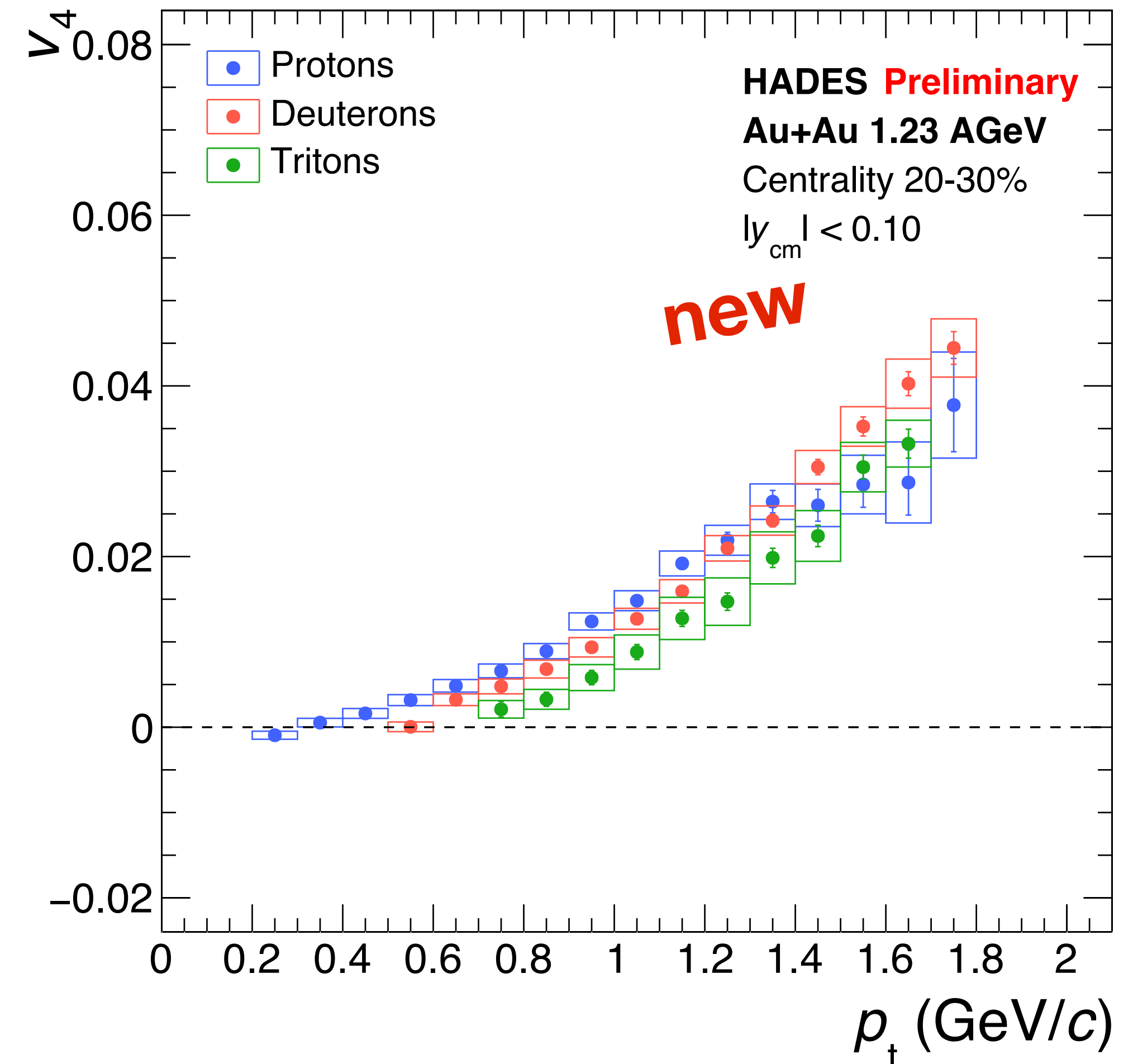

$$v_4\{\Psi_{RP}\} = \langle\langle \cos 4(\varphi - \Psi_{RP}) \rangle\rangle$$

Note: $v_4\{\Psi_{RP}\}$ w.r.t reaction plane

Quadrangular Flow $v_4\{\Psi_{RP}\}$

Protons and Light Nuclei

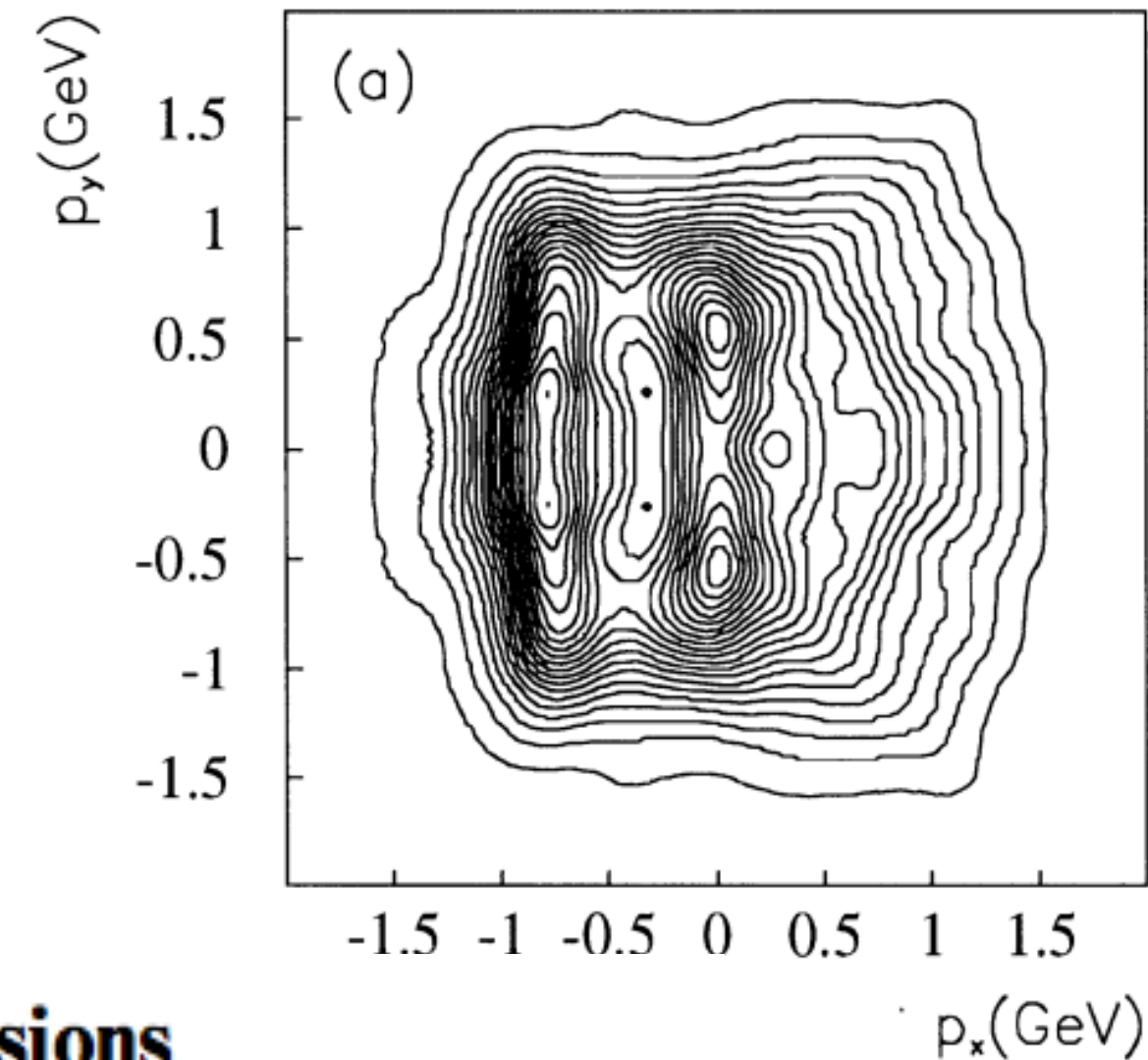

Z. Phys. C 70, 665–671 (1996)

**Flow study in relativistic nuclear collisions
by Fourier expansion of azimuthal particle distributions**

S. Voloshin^{1,*}, Y. Zhang²

The rectangle-type deformation amplitude v_4 could be non-zero, for example, for rapidity windows close to the center of mass, where both squeeze-out emitting preferentially more particles in the direction perpendicular to the reaction plane, and “side-splash” effects can be important.

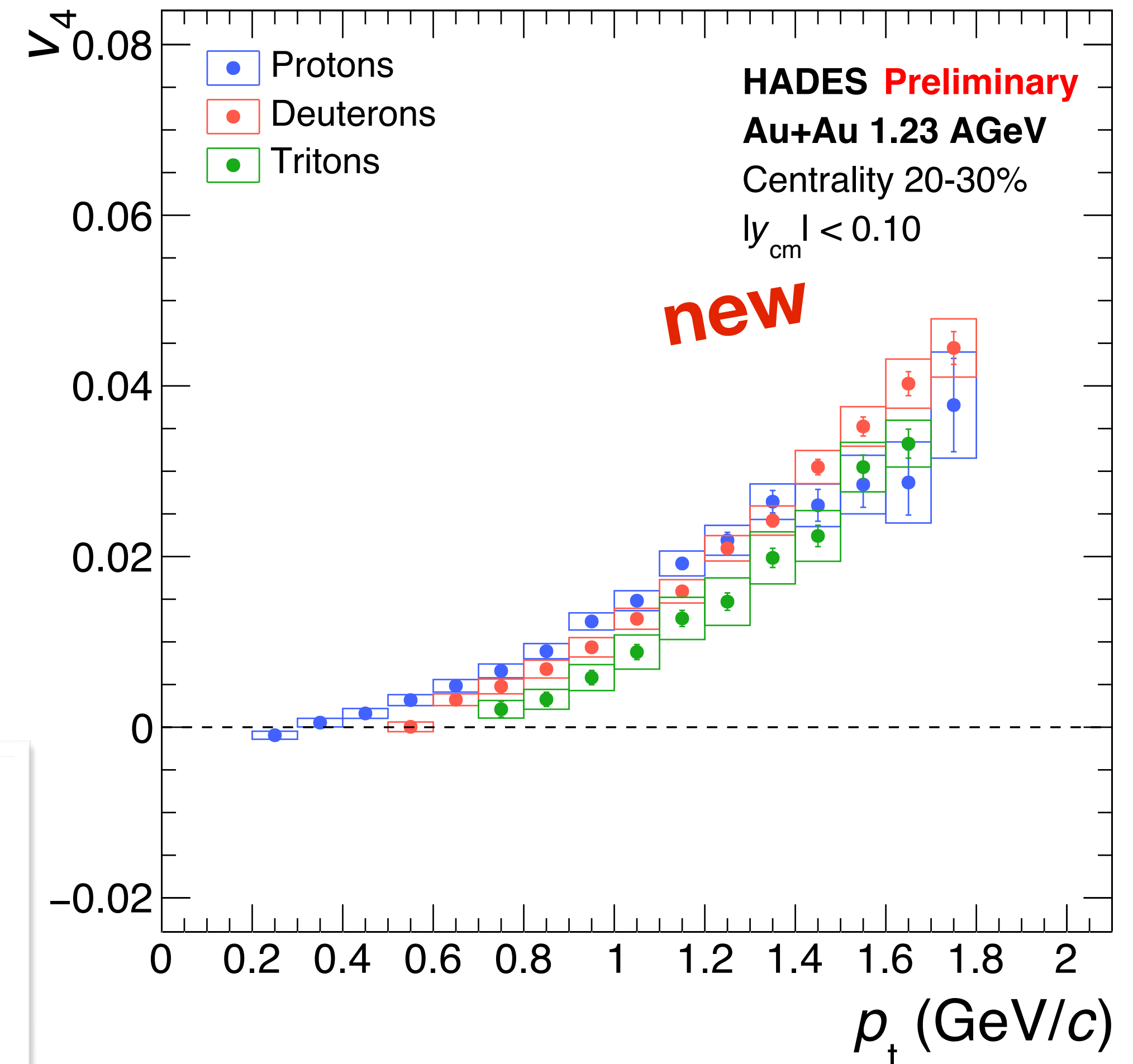

$$v_4\{\Psi_{RP}\} = \langle\langle \cos 4(\varphi - \Psi_{RP}) \rangle\rangle$$

Note: $v_4\{\Psi_{RP}\}$ w.r.t reaction plane

Quadrangular Flow $v_4\{\Psi_{RP}\}$

Protons and Light Nuclei

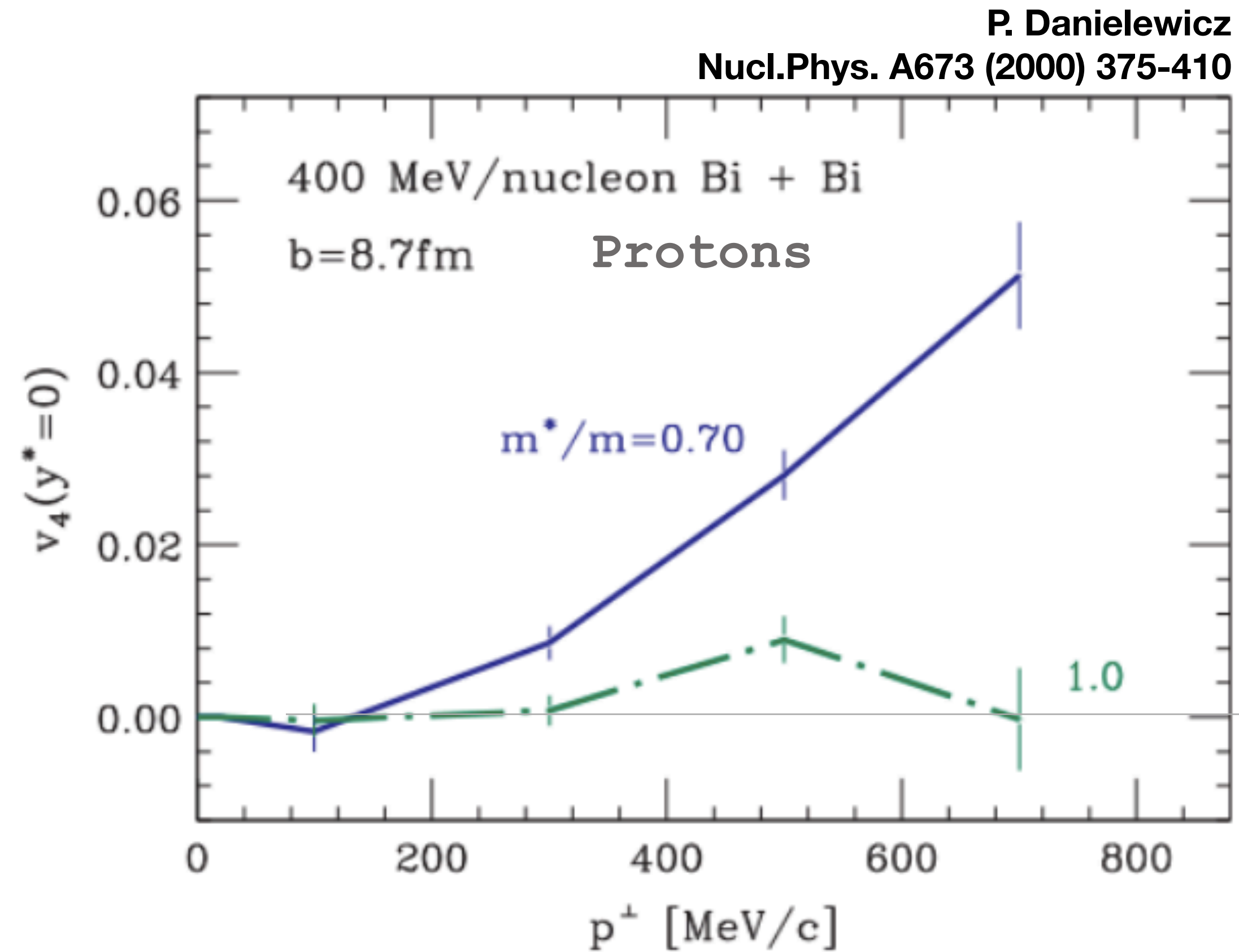

First prediction of v_4 with sensitive to EoS

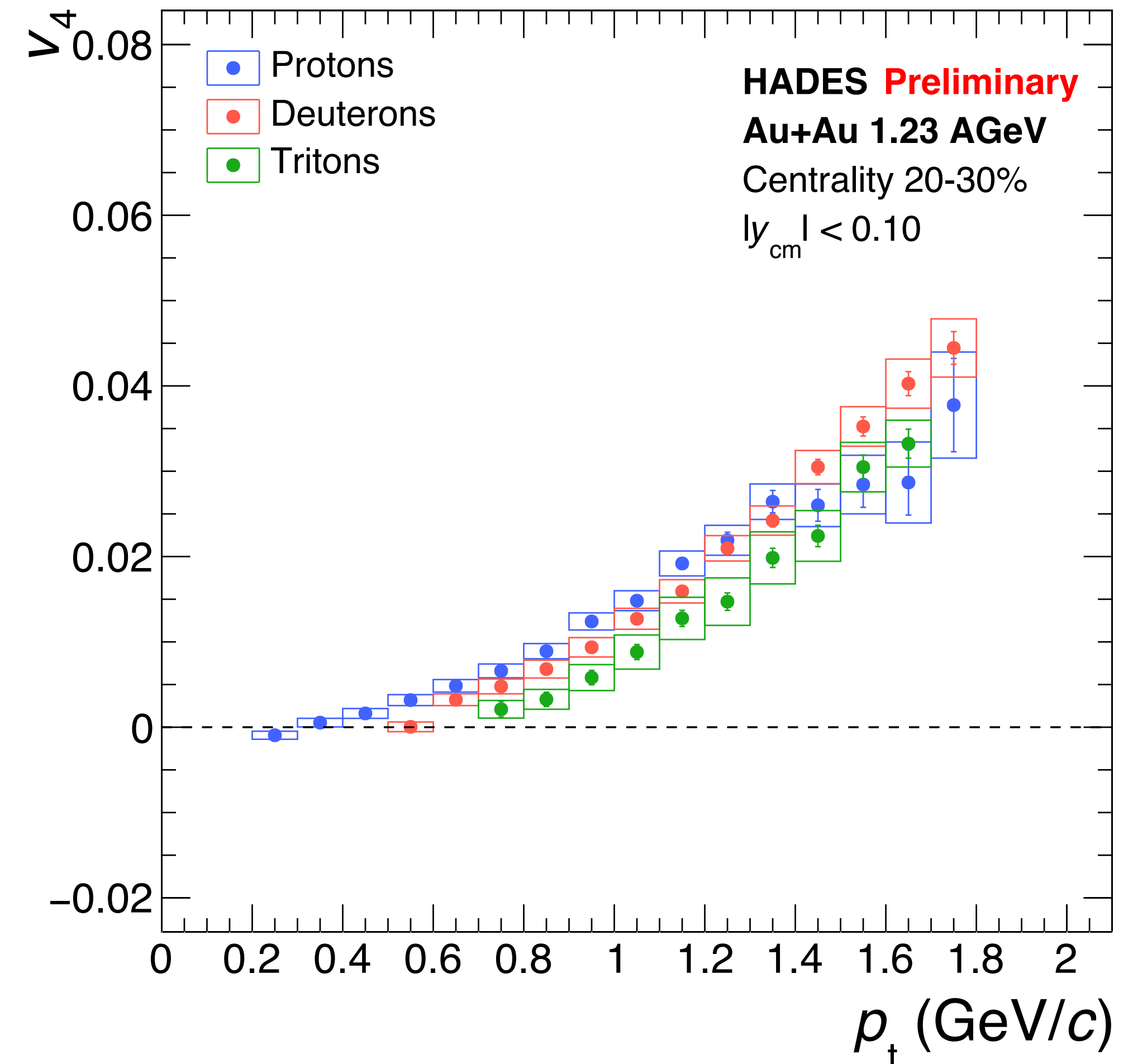

$$v_4\{\Psi_{RP}\} = \langle\langle \cos 4(\varphi - \Psi_{RP}) \rangle\rangle$$

Note: $v_4\{\Psi_{RP}\}$ w.r.t reaction plane

Conclusions

- Freeze-out parameters via Blast-Wave fit:

$$T_{kin} = 66 \pm 8 \text{ MeV}$$

$$\langle \beta_r \rangle = 0.34 \pm 0.04$$

- Directed v_1 and elliptic v_2 flow of protons, deuterons and tritons

- ▶ Elliptic flow at mid-rapidity scales with A

- First measurement at SIS energies of

- ▶ Triangular $v_3\{\Psi_{RP}\}$ and quadrangular $v_4\{\Psi_{RP}\}$ of protons, deuterons and tritons

- ▶ Substantial difference in Pion HBT in Au+Au due Coulomb potential

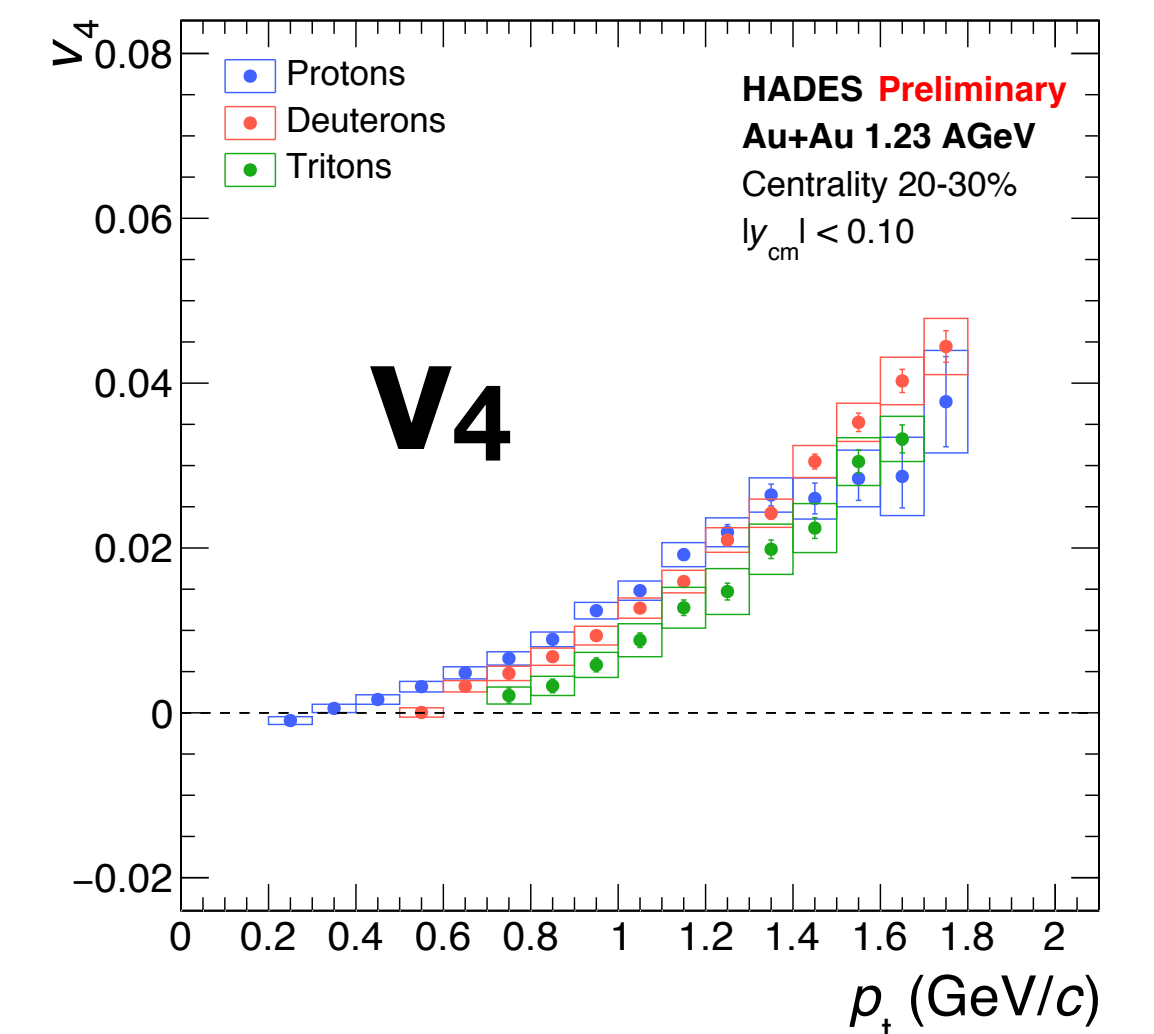
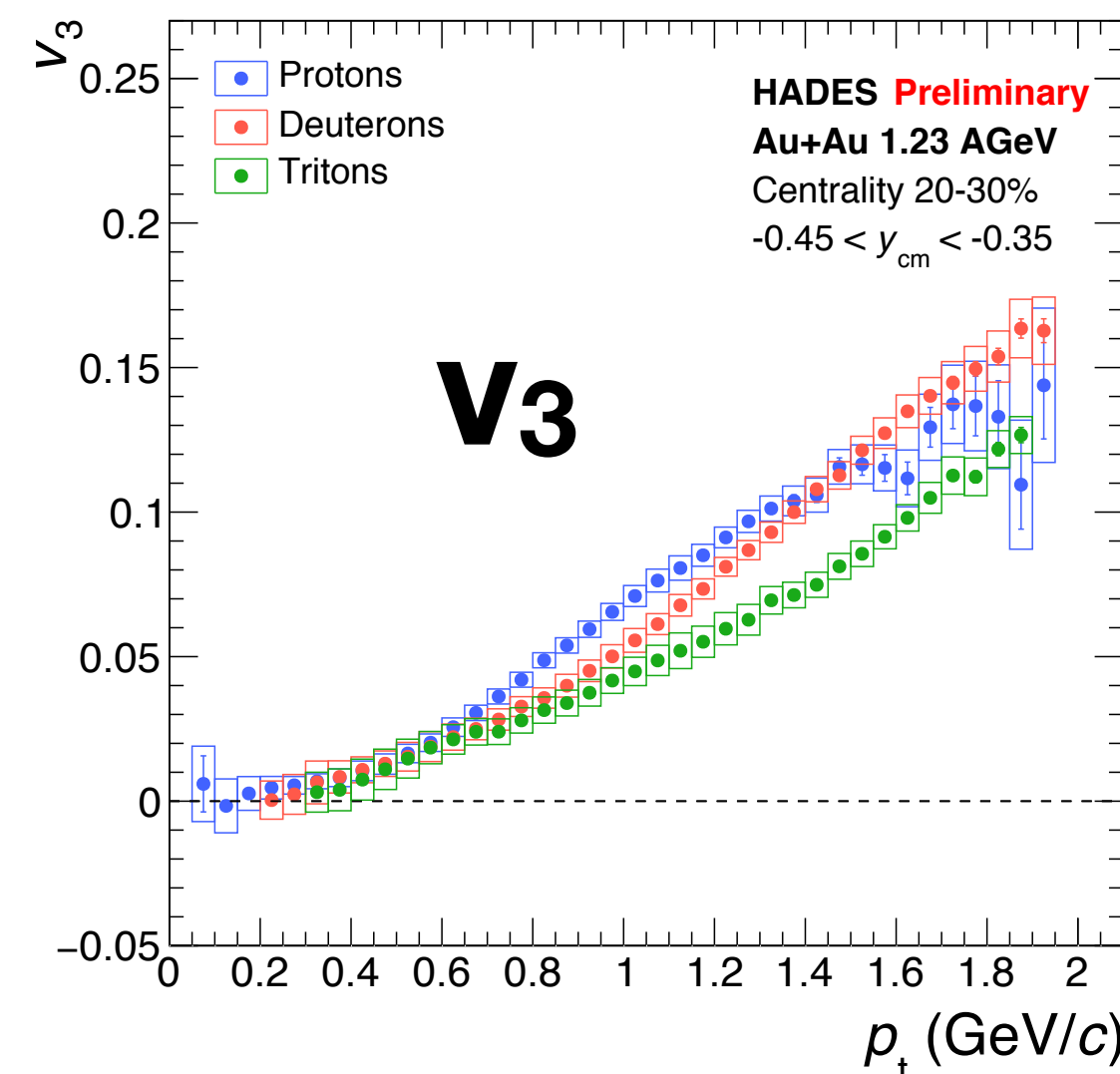
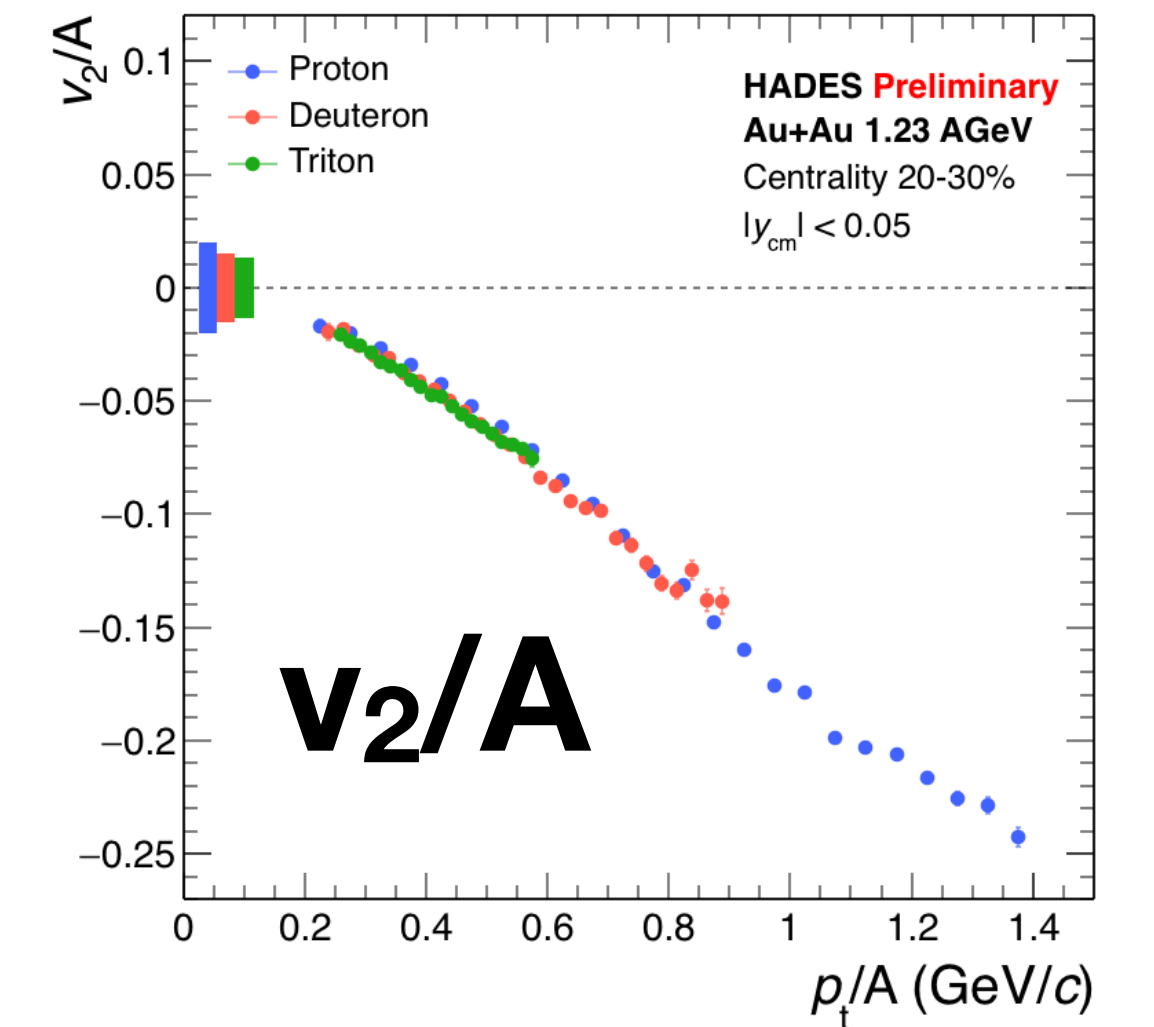
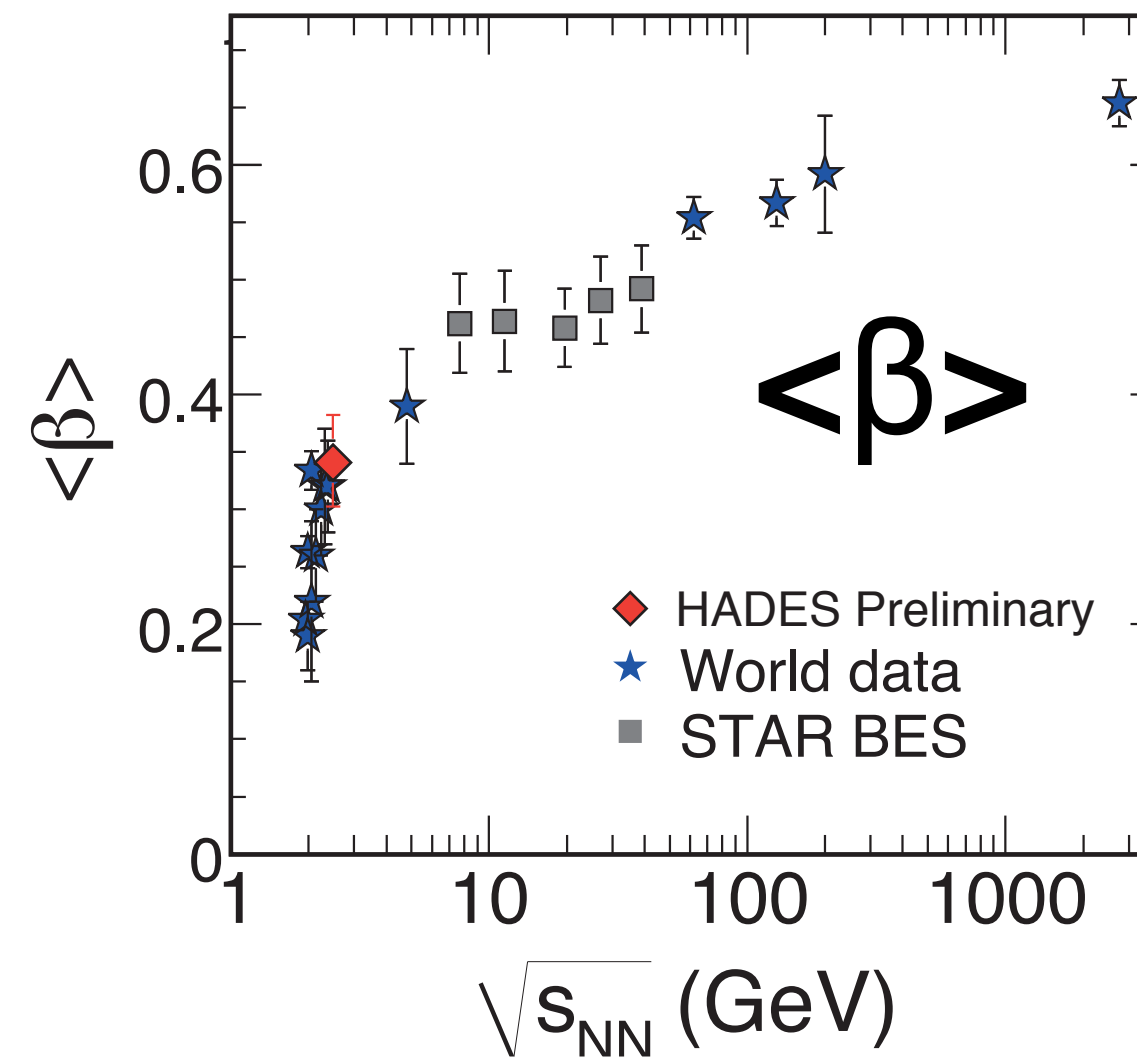



HADES Collaboration

HADES Performance

- High interaction rates and statistics
 - ▶ Total number of events recorded: 7×10^9
 - ▶ 2.1×10^9 most central events analysed
- Centrality
 - ▶ 0-40% most central
 - ▶ Deduced from a Glauber MC model

