



EMC BWE PANDA Services and Mounting Platform

PANDA LII Collaboration Meeting
Mechanical Session
17-Mar-2015



Services

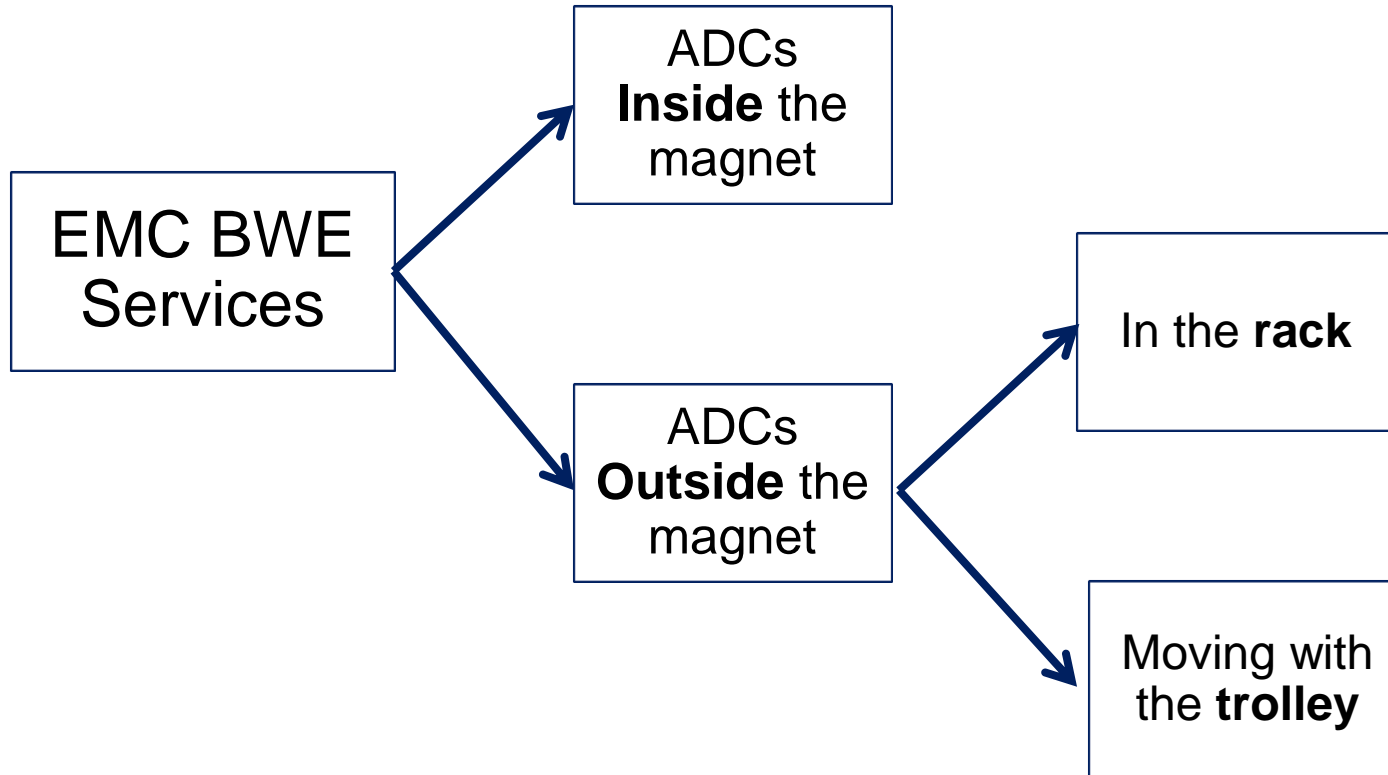

Service	Cross Section (mm ²)	Where it goes
HV	1690	Rack/E10
ASICs (Power line)	392	Rack
ASICs (Sensing line)	200	Rack
ADCs (Power line)	800	Rack/E10
ADCs (Sensing line)	200	Rack/E10
Splitter boards (Power line)	392	Rack
Splitter boards (Sensing line)	200	Rack
ADCs Optical link	7	Rack/E10
Gases, N ₂	200	Building Supply
Readout Cooling, THMP	19	Rack/E10
Detector Cooling	25600	EMC Cooling Plant
Programming Lines	387	Rack/E10
Optical Fibers	886	Rack
ADCs Cooling (Water)	392	Building Supply
TOTAL	31364	
	314 (cm²)	

Service	Cross Section (mm ²)	Where it goes
HV	1690	Rack/E10
ASICs (Power line)	392	Rack
ASICs (Sensing line)	200	Rack
Splitter boards (Power line)	392	Rack
Splitter boards (Sensing line)	200	Rack
CAT Cables	20960	Rack
Gases, N ₂	200	Building Supply
Readout Cooling, THMP	19	Rack/E10
Detector Cooling	25600	EMC Cooling Plant
Programming Lines	387	Rack/E10
Optical Fibers	886	Rack
TOTAL	50926	
	509 (cm²)	

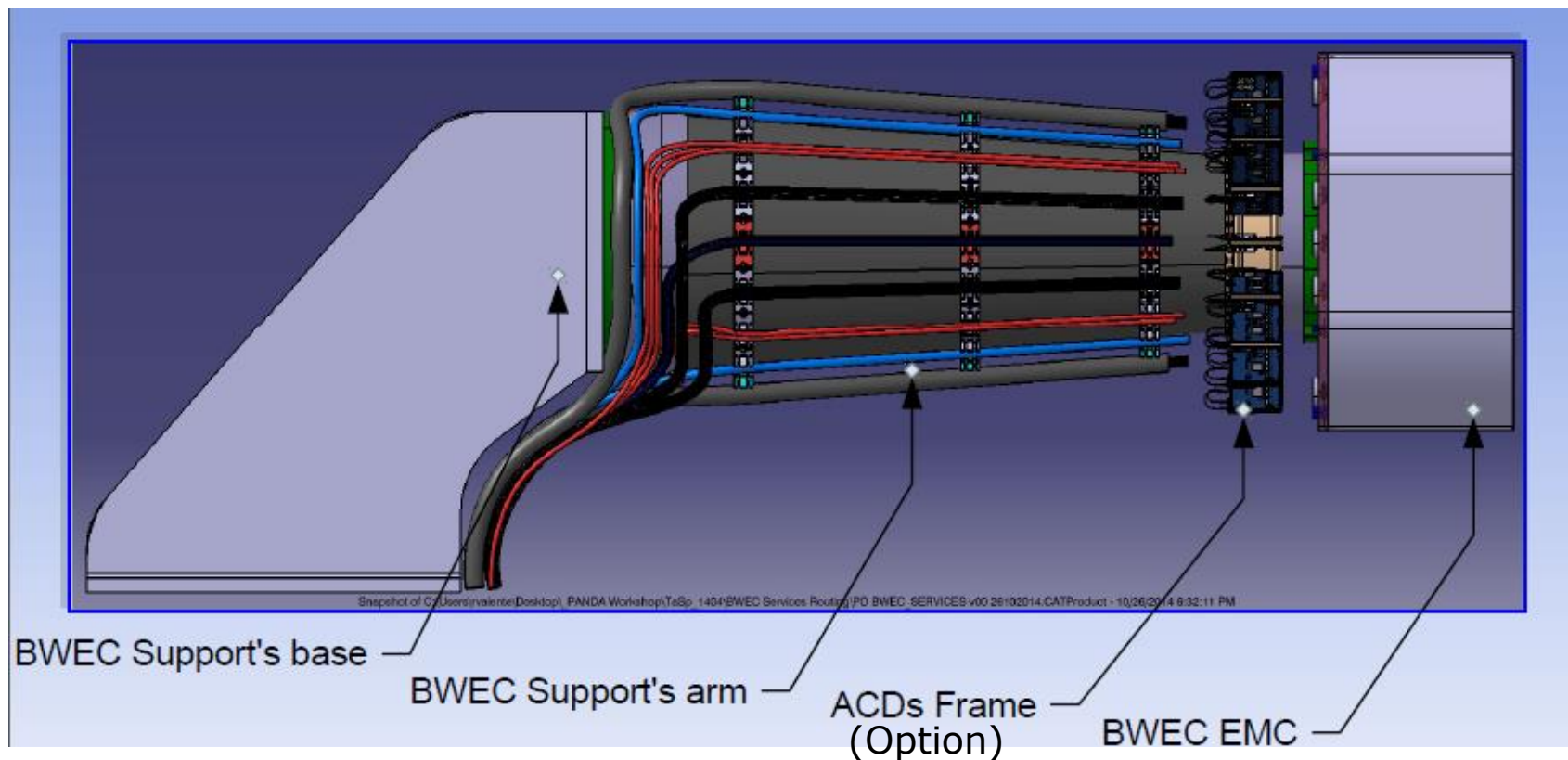

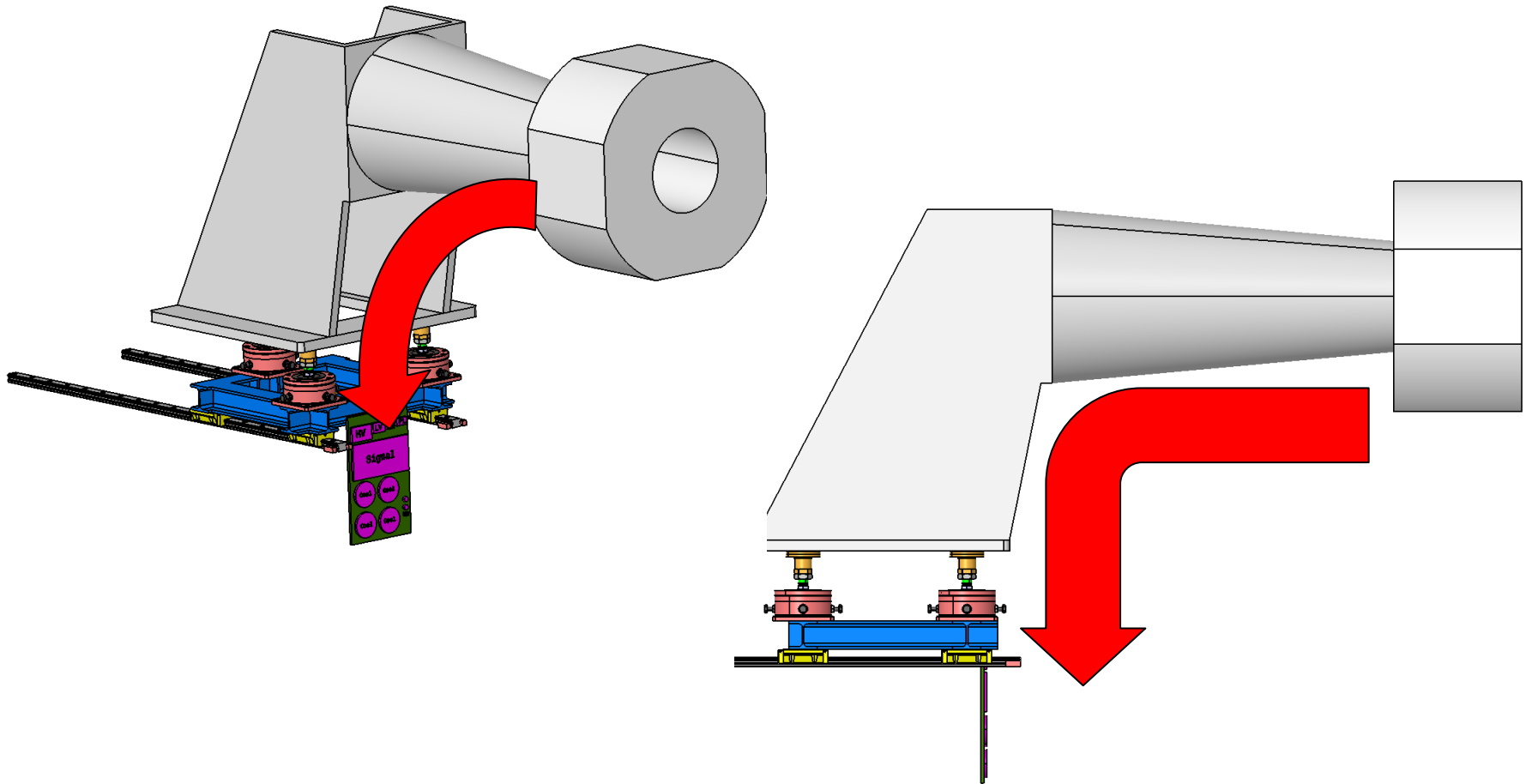

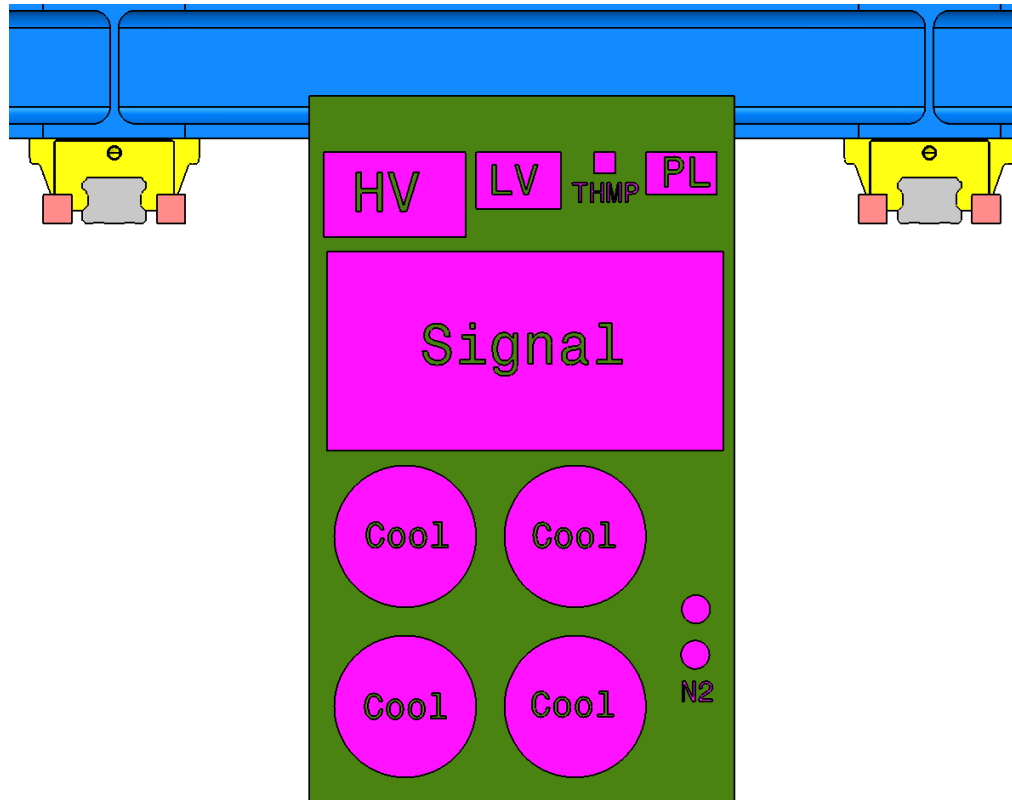

Services go to
Patch Panel
 which is fixed on
 the BWE trolley.

Possibility: **ADCs**
 also fixed on the
 trolley

Optic Fibers go
 directly to the
rack

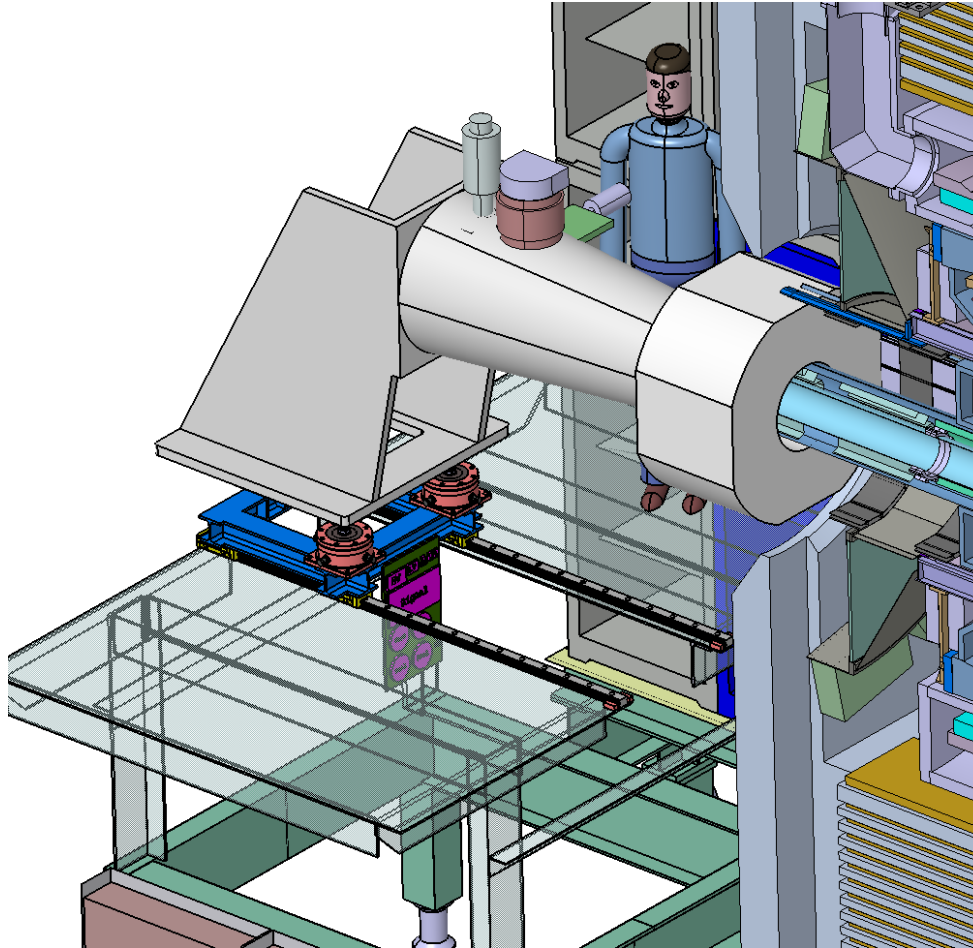

Patch Panel
moves with the
BWE trolley
along the rails
on both the
Auxiliary and
Mounting
Platforms

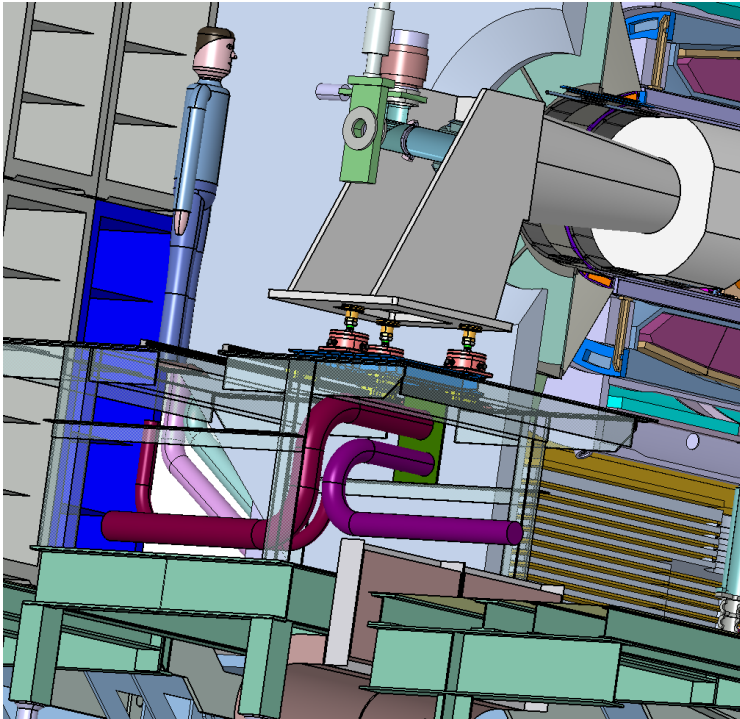

Services go below the
Auxiliary platform

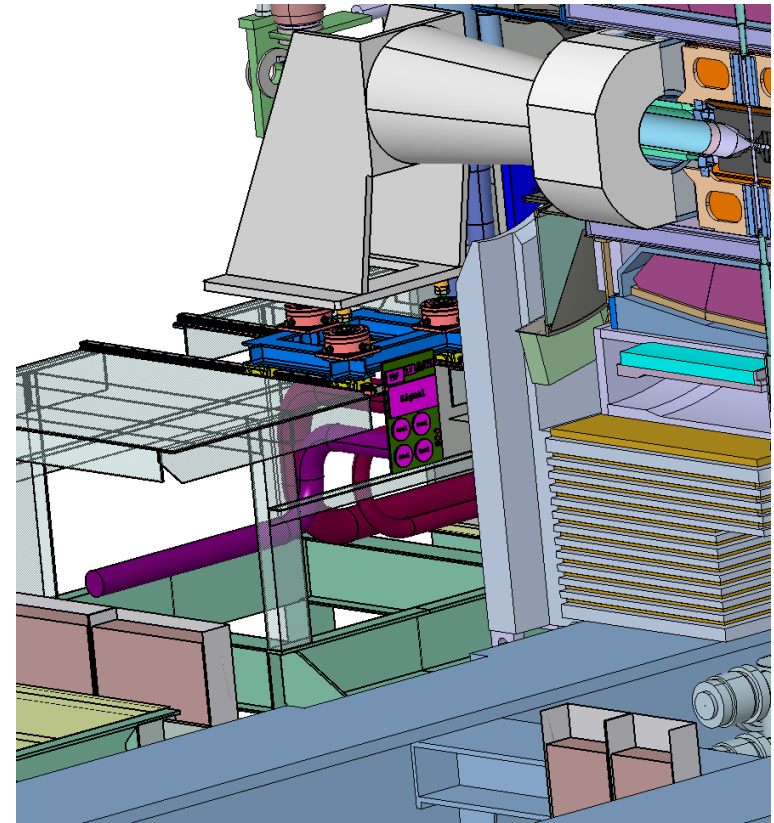

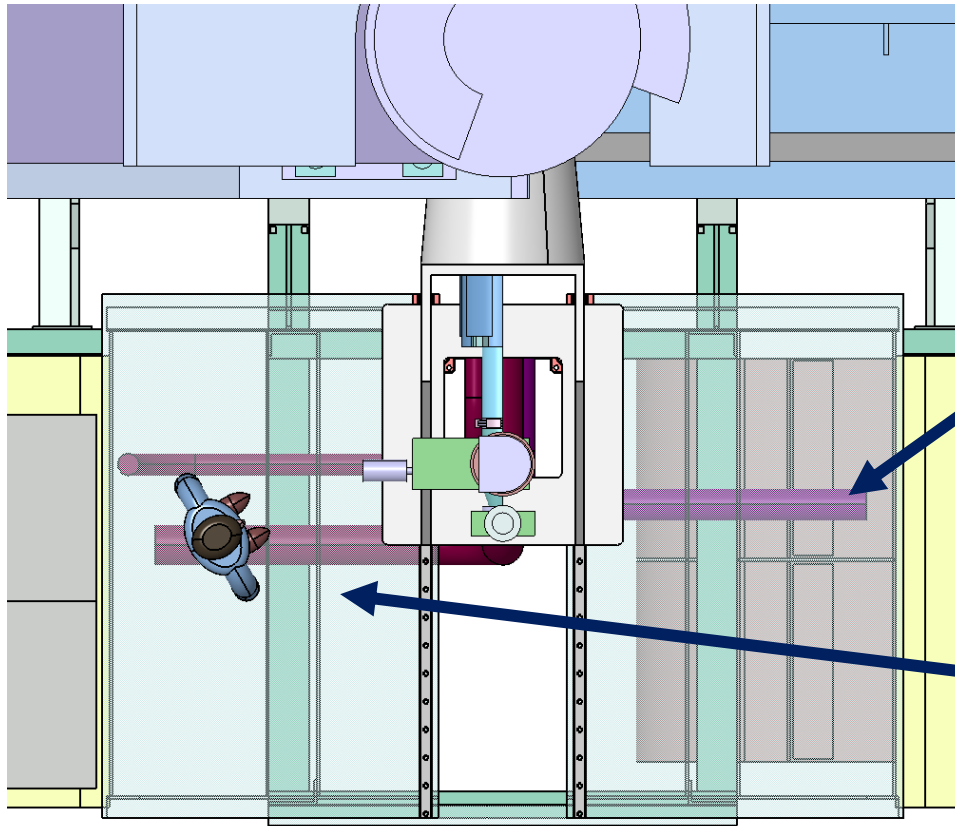

EMC Cooling,
Cooling **water,**
Nitrogen goes
to Cooling Plant
and hall supplies

Everything else
goes to the
Upstream,
West, Bottom
Rack and E10
Level

- Space between Auxiliary Platform and Racks??
- MVD Services, through BWE trolley??

Mounting Platform

From the last December MEC meeting

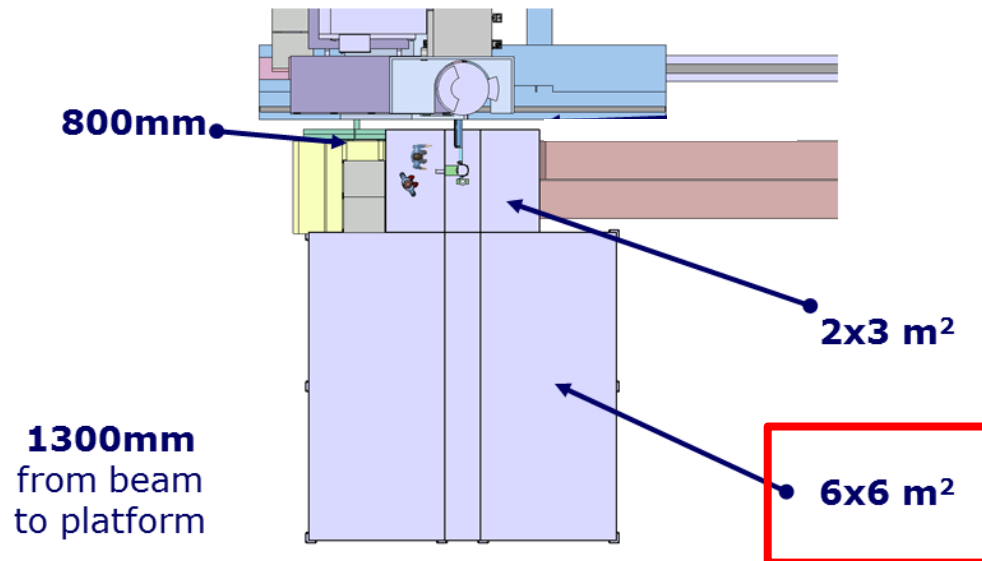

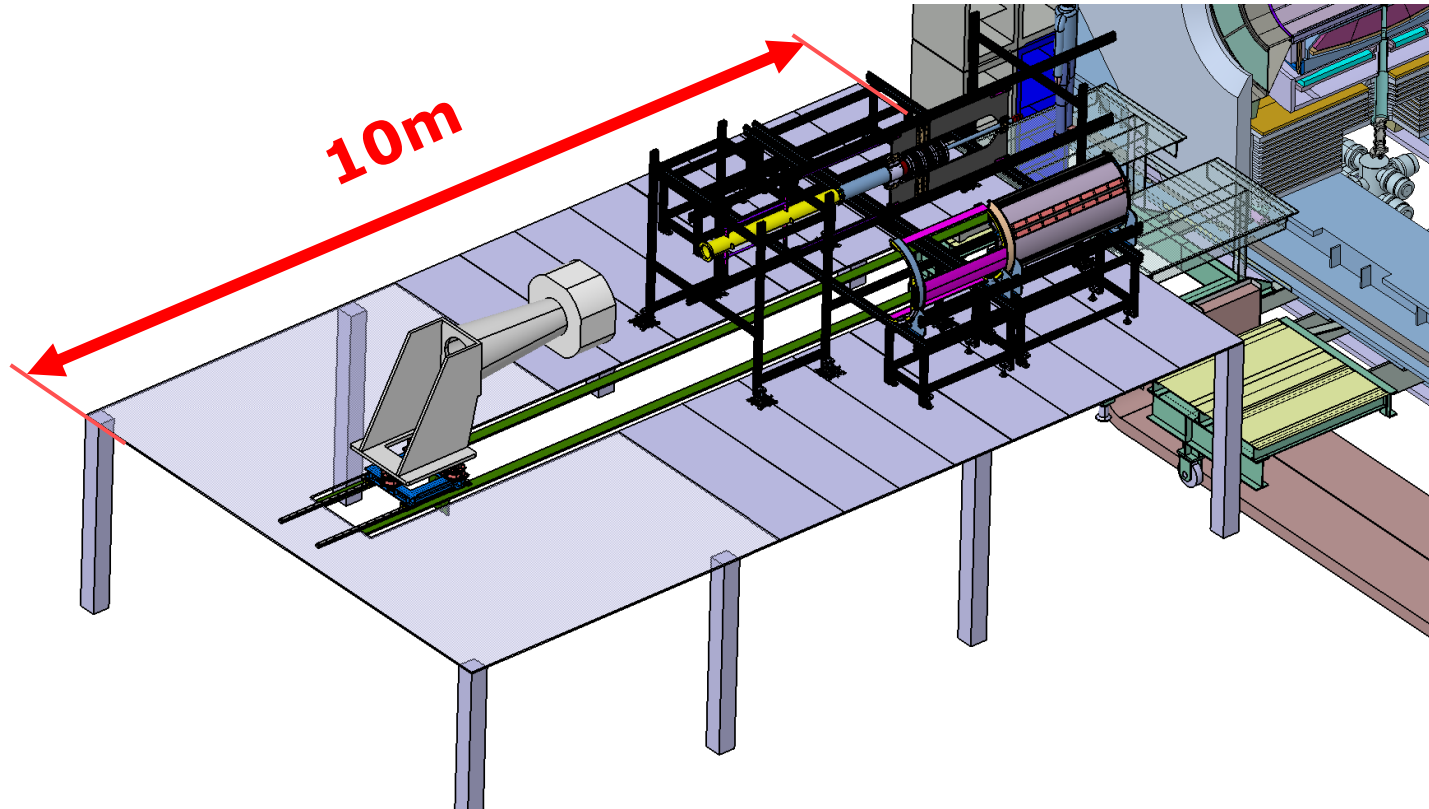

In order to mount MVD/STT and BWE **in parallel** we need a **10 meter** Platform

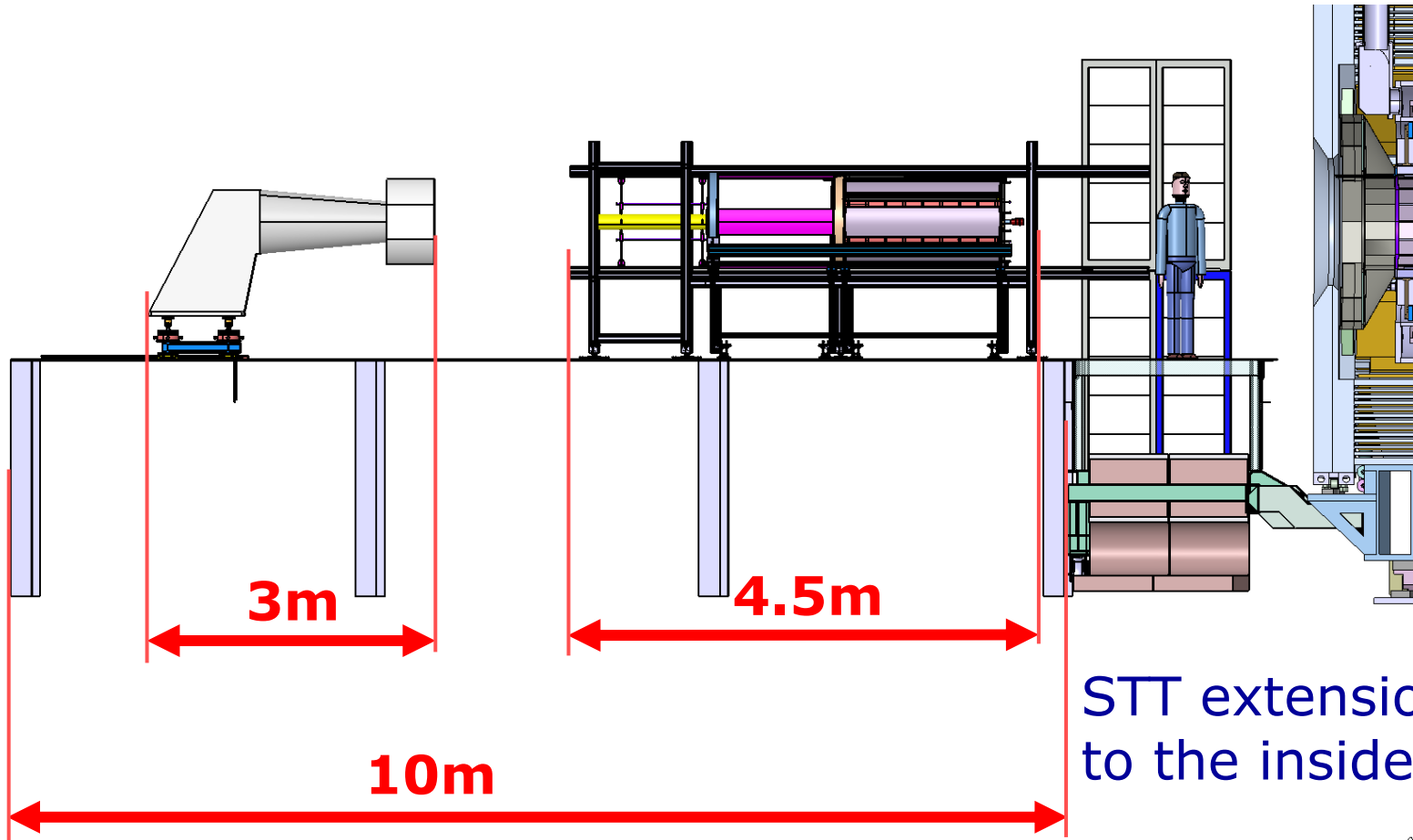

0

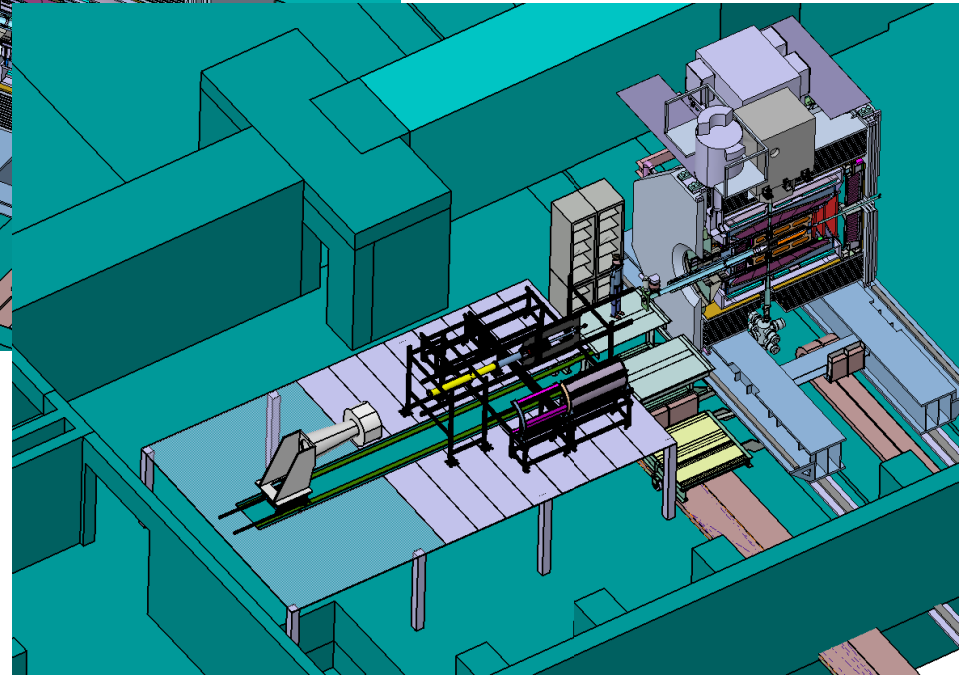
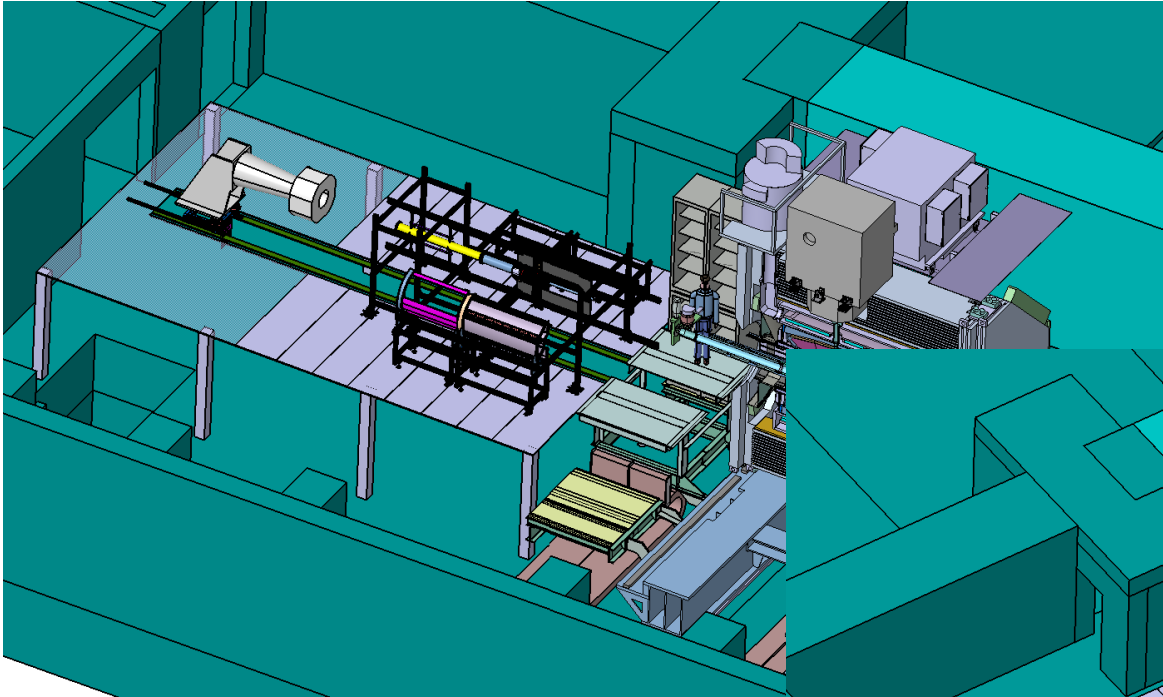

Platform too big for the PANDA hall?

Above the cooling pit?

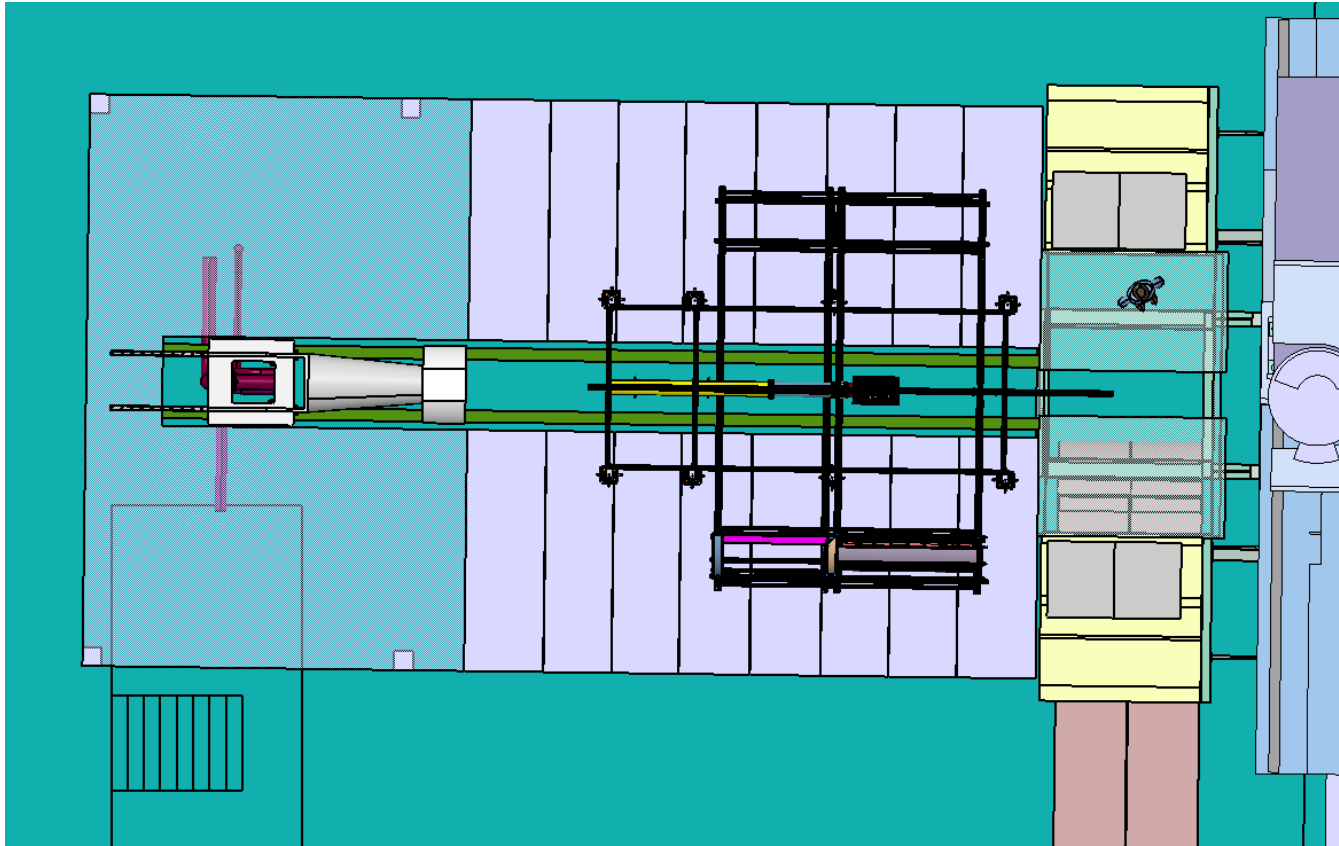

Movable racks and **extensions** to the Auxiliary Platform?

Thank you

H. Ahmadi
S. Ahmed
L. Capozza
M. Deiseroth
F. Maas
O. Noll
D. Rodríguez Piñeiro
R. Valente