

The show MUST begin

MUST work packages and cost estimate

Shreya Roy

Anastasios Belias

On behalf of the MUST group

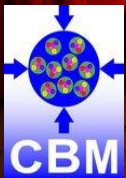

CBM PANDA



MUST : Work packages



Detector components



Services : LV, HV,
gas, cooling



MUST software

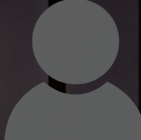

Detector tests
& QA



FEE



DAQ



Gas system



Mechanics



Commissioning



Installation



DCS, Monitoring

WP1 : Detector components

Objective:

To re-qualify all existing LHCb Outer Tracker (OT) hardware components—including straw modules, C-frames—for reuse as part of the MUST detector in CBM.

Tasks:

- 1.1 Provide C-frames with straw modules (LHCb)
- 1.2 Provide straw modules with electronics box (LHCb)

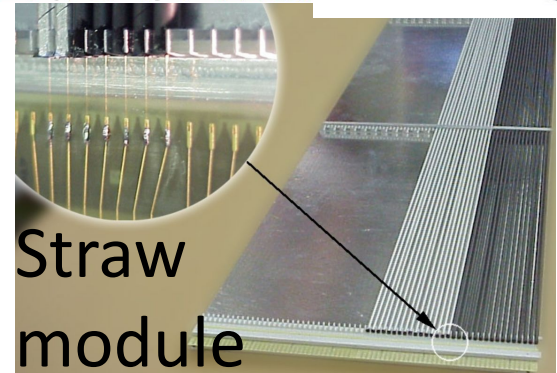
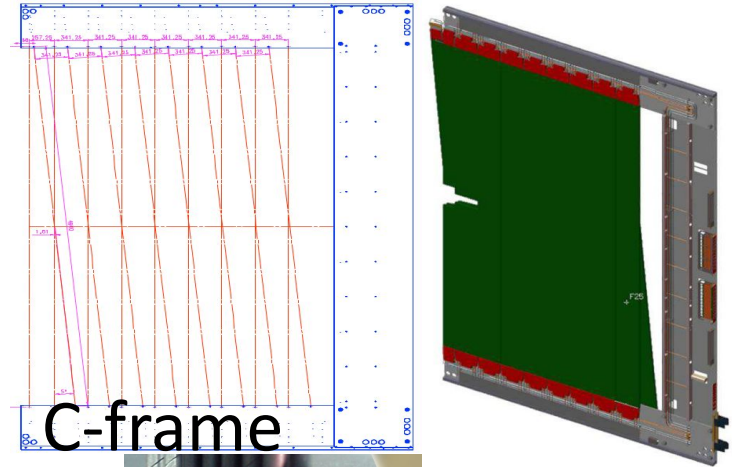

WP2 : Detector services

Objective:

Preparation/procurement of on- and off-detector parts and services required for reuse of LHCb OT as the MUST detector in CBM.

Tasks:

- 2.1 LV, connectors, cables
- 2.2 HV, connectors, cables
- 2.3 Gas (Ar/CO₂/O₂)
- 2.4 Cooling water



LV power supply

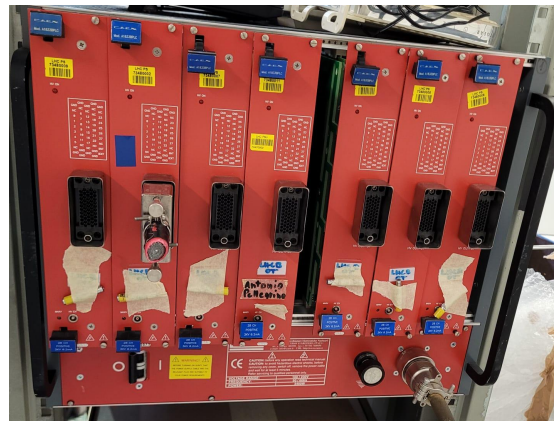

MUST HV supply

WP3 : Mechanics

Objective:

Design, production, and integration of new mechanical structures required to install MUST in CBM

Tasks:

- 3.1 Transport and handling frame
- 3.2 Support structure for detector and absorbers
- 3.3 Mechanical integration into MUCH
- 3.4 Mechanical simulations (deformation analysis, load and stress calculations, stability and safety)
- 3.5 Production and assembly
- 3.6 Installation in CBM

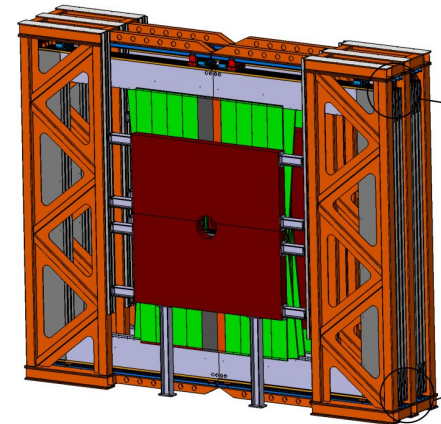
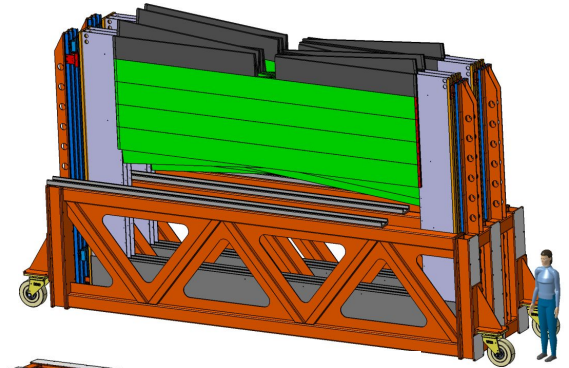

design by Stefan Koch

WP4 : Gas System

Objective:

Design, construction, integration, and commissioning of the gas system for MUST operation in CBM.

Tasks:

- 4.1 Gas system design
- 4.2 Operational parameters
- 4.3 Control and monitoring (DCS integration)
- 4.4 Leak tests
- 4.5 System installation in CBM

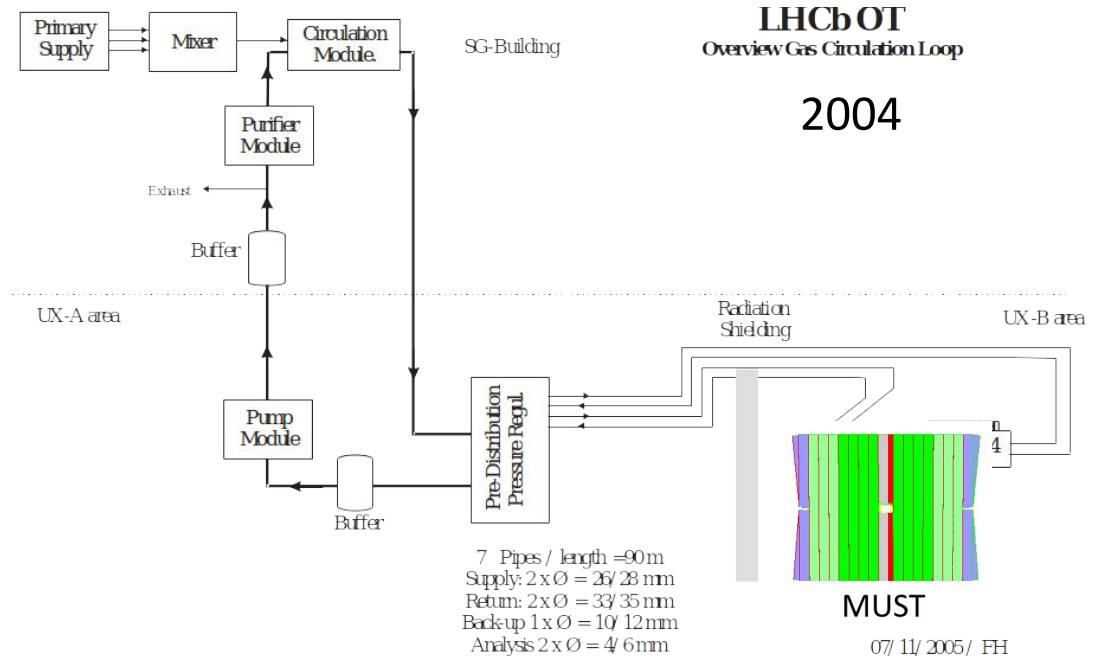

Refs : Performance of the LHCb Outer Tracker 2014 JINST 9 P01002

WP5 : Front End Electronics

Objective:

To develop and integrate all front-end electronics, digital readout needed to run MUST in the CBM environment.

Tasks:

- 5.1 Analogue readout (ASDBLR, LHCb ASICs)
- 5.2 Digital Readout DiRich (DOGMA based, CBM-FAIR Interface)

Front-End Electronics Development at GSI

LHCb OuterTracker
straw-tubes Readout

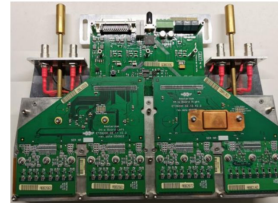

PaSta @ mCBM
Readout



MuSt @ CBM
Readout

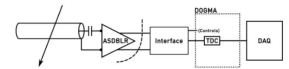
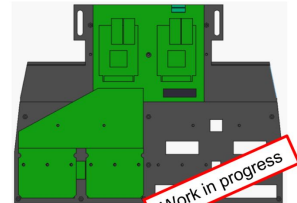

WP6 : DAQ

Objective:

To create DAQ interfaces

Tasks:

6.1 DAQ and integration to CBM [DOGMA]

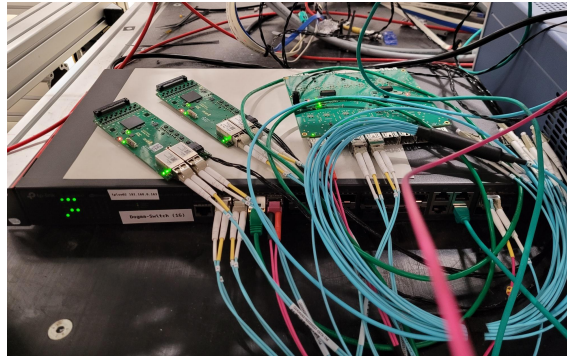

https://redmine.cbm.gsi.de/projects/mcbm/wiki/DOGMA_setup

WP7 : DCS and Monitoring

Objective:

To integrate into DCS

Tasks:

- 7.1 DCS and integration to CBM
- 7.2 HV, LV, gas, and cooling interface
- 7.3 Monitoring and control software
- 7.4 Alarm and safety (DSS)
- 7.5 Data logging and database integration
- 7.6 Testing and commissioning

Power Supply **HMP4040 DOGMA** [connected to **IP10.203.30.9**]

	1 - LV		2 - LV		3 - LV		4 - LV	
Voltage [V]	1.800	set	3.000	set	3.800	set	12.000	set
Actual[V/A]	1.800	2.337	3.000	0.375	3.800	0.581	12.000	0.471
Limits[V/A]	32.500	3.000	32.500	3.000	32.500	3.000	32.500	3.000
Output Relais	on	off	on	off	on	off	on	off
Global Switch	ON OFF							
<input checked="" type="checkbox"/> Enable read-back of values					Read settings	Go		
								15:39:59

https://redmine.cbm.gsi.de/projects/mcbm/wiki/DOGMA_setup

WP8 : Detector tests and QA

Objective

Perform full functional and performance validation of all MUST hardware prior to installation and during commissioning.

Tasks:

- 8.1 Dismounting of C-frames and modules
- 8.2 Testing of individual modules with electronics box (LHCb)
- 8.3 Detector data analysis & Quality Assurance(QA)
- 8.4 Acceptance tests of 264 MUST modules
- 8.5 Integration of front-end electronics and cabling

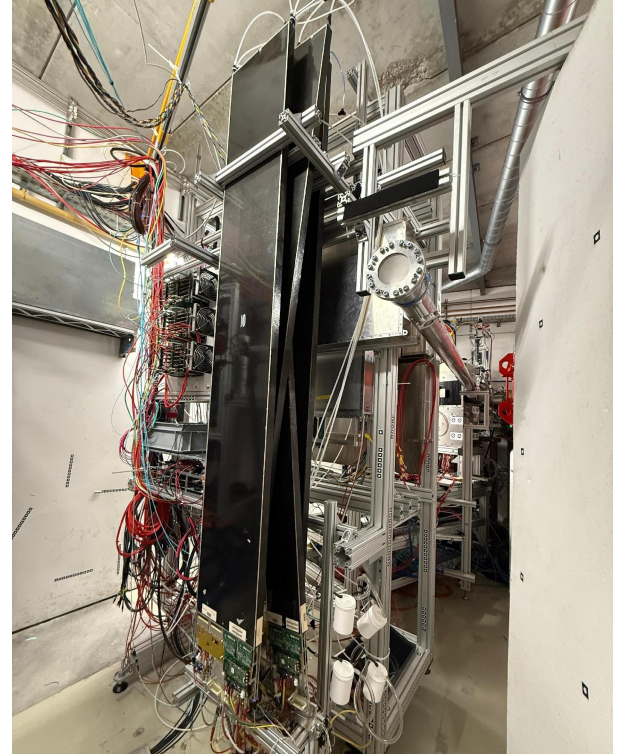

WP9 : MUST software

Objective:

Develop and integrate the full simulation, digitisation, reconstruction framework in CBMROOT.

Tasks:

- 9.1 Simulation within the CBM Framework (geometry, digitisation, reconstruction, tracking, PID)
- 9.2 Validation & Performance evaluation of the software
- 9.3 Physics analysis
- 9.4 Computing tasks

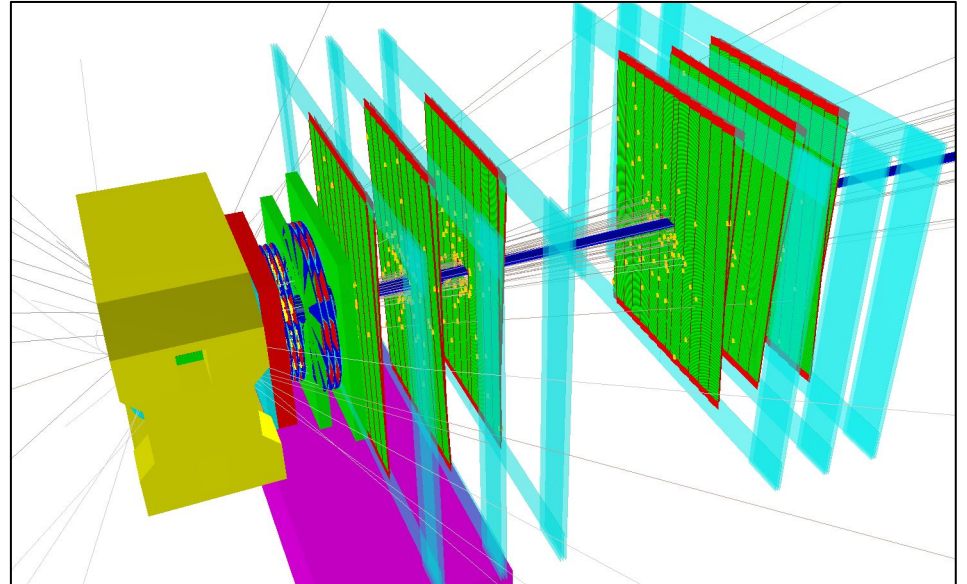

WP10 : Installation

Objective:

Install the MUST detector and all associated infrastructure in the CBM cave. Detector fully installed and connected.

Tasks:

- 10.1 Installation of detector MUCH/MUST support structures
- 10.2 Transport to CBM and installation of MUST stations
- 10.3 Installation of gas system, LV, HV, DCS, service infrastructure in CBM
- 10.4 Integration into CBM DAQ (optical backbone)



WP11 : Commissioning

Objective:

Commission MUST and validate its performance for stable operation during CBM data taking.



















Tasks:

11.1 Alignment & Calibration in CBM

11.2 Online monitoring and QA validation



Work package status table

WP	Description	Progress	Lead/Institute
1	Detector components : C-frames, modules	50% 	GSI (from LHCb)
2	Services : LV, HV, gas, cooling	20% 	India, GSI,(HV from LHCb)
3	Mechanics : support structure	10% 	GSI, 
4	Gas System	0% 	
5	Front end electronics	20% 	GSI, 
6	DAQ	20% 	Cracow, GSI, 
7	DCS	10% 	China, 
8	Detector tests and QA	10% 	GSI, India, 
9	MUST software & analysis	40% 	GSI, India, 
10	Installation	0% 	GSI, India, 

Cost estimate

	Component	Work packages	Total cost (k€)
1	Low Voltage (LV)	WP2	140
2	High Voltage cable infrastructure (HV)	WP2	80
3	Mechanics (MUST support structure)	WP3	140 (+70 for Abs #5 frame)
4	Gas system (open mode operation)	WP4	220
5	FEE + DOGMA components, optical interface	WP5, WP6	740
6	Cooling water monitoring and distribution	WP2	25
7	Installation and transport, e.g. cranes	WP1, WP3, WP10	50
	Total		1.400 k€

Backup

Cost Estimate

Man power...

Component	Units needed	Cost per unit (€)	Total cost (€)
1) LV power supplies (Rack CBMPRT.006) (off-detector)	6	12k	72k
2.1) LV cables (35 mm ² , e.g. SCEM 04.08.61.935.8)	3840m	4	16k
2.2) LV connectors (SCEM 06.01.15.520.0)	96	3	300
3) LV distribution in module (on-detector)	1k	50	50k
4) HV power supplies (CAEN A1833BPLC 8x) (main frames, off-detector)	2	0	0
5.1) HV cables (16 pcs, 40 m)	640m	6/m	4k
5.2) HV connectors (32 pcs)	32	450	15k
5.3) HV patch panels	1008*4		12k
6.1) HV patch cables (12 x 4 pcs, 5m)	240m	6/m	1440
6.2) HV patch cable connectors (2 x 12 x 4 pcs)	96	450	44k
7) HV boards on detector	1k	0	0
8) Module interface board	1008	50	50k
9.1) FEE, ASDBLR ASIC	4032	0	0
9.2) FEE, TDC FPGA Readout DOGMA	1008	400	404k
10.1) DOGMA data fibres (+1 SFP)	1008	50	51k
10.2) DOGMA control fibres	1008	50	51k
10.3) DOGMA Control Module	48	400	24k
10.4) SFP for data, SFP to DCM	2016	12	24k
11) Ethernet Switch (data)	48	800	40k
**check radiation levels			
12) DOGMA CRI patch fibers	48	500	24k
13) CRI: FLX-155B	6	11k	66k
14) MUST gas inlet/outlet pipes	12	1k	12k
15) Gas mixing system	1	150k	150k
16) Gas distribution system	2	20k	40k
17) Gas Ar /CO ₂ /O ₂ bottles (50l)	140/31/3	45/120/13	10k
18) Cooling water monitoring and distribution	1	25k	25k
19) Mechanics: MUST support structure	2	67k	132k
20) Installation and transport, e.g. crane			50k
Total			1.37M

MUST Work Package Structure

1. Detector components - GSI from LHCb
2. Services - HV (ok), LV (needed), cooling (needed), gas (needed)
3. Mechanics -(Stefan)
4. Gas system
5. FEE - (GSI/EEL)
6. DAQ - (Greg)
7. DCS , Monitoring software (Peter Z.,)
8. Detector tests & QA
9. MUST software and analysis
10. Installation
11. Commissioning/operation -

Work package summary table

WP	Description	Exist	Location	WPL	Timeline
1	Detector components and services				
1.1	C-frames with straw modules (LHCb)	YES	GSI		
1.2	Straw modules with electronics box (LHCb)	YES	GSI		
1.3	On-detector services (LV)	No	GSI		
1.4	On-detector services (HV)	Part	GSI		
1.5	MUST Gas system	No	GSI		
1.6	On-detector services (Cooling)	Part	GSI		
2	Mechanics				
2.1	Revisit C-frame module assembly for MUST	NO			
2.2	Integration of C-frames to Stations for MUST	NO			
2.3	Mechanical integration of MUST in MUCH	NO			
3	FEE, DAQ, DCS				
3.1	Analogue readout (LHCb ASICs)	YES	GSI		
3.2	Digital Readout DiRich	Part	GSI		
3.3	Digital readout DOGMA (with interface)	NO			
3.4	DAQ and integration to CBM [DOGMA]	NO	GSI		
3.5	DCS and integration to CBM	NO			
4	Detector tests				
4.1	Testing of Individual Modules with LHCb electronics box	Part			
4.2	Acceptance tests of MUST modules	NO			
4.3	Dismounting of C-frames and modules	NO			
4.4	Detector data analysis & Quality Assurance(QA)	NO			
5	MUST software integration in CBMROOT				
5.1	Simulation within the CBM Framework	Part			
5.2	Validation & Performance evaluation of the software	NO			
5.3	Computing tasks	NO			
6	Installation, Commissioning and Monitoring				
6.1	Installation of gas system, LV, HV infrastructure in CBM	NO			
6.2	Integration into CBM DAQ (optical backbone)	NO			
6.3	Alignment & Calibration in CBM	NO			

To
be
filled
up

Time is short.

Need you to contribute in any of the work packages.

Contact : S. Roy, A. Belias¹⁹