

MUST Support Structure and transport to the CBM cave

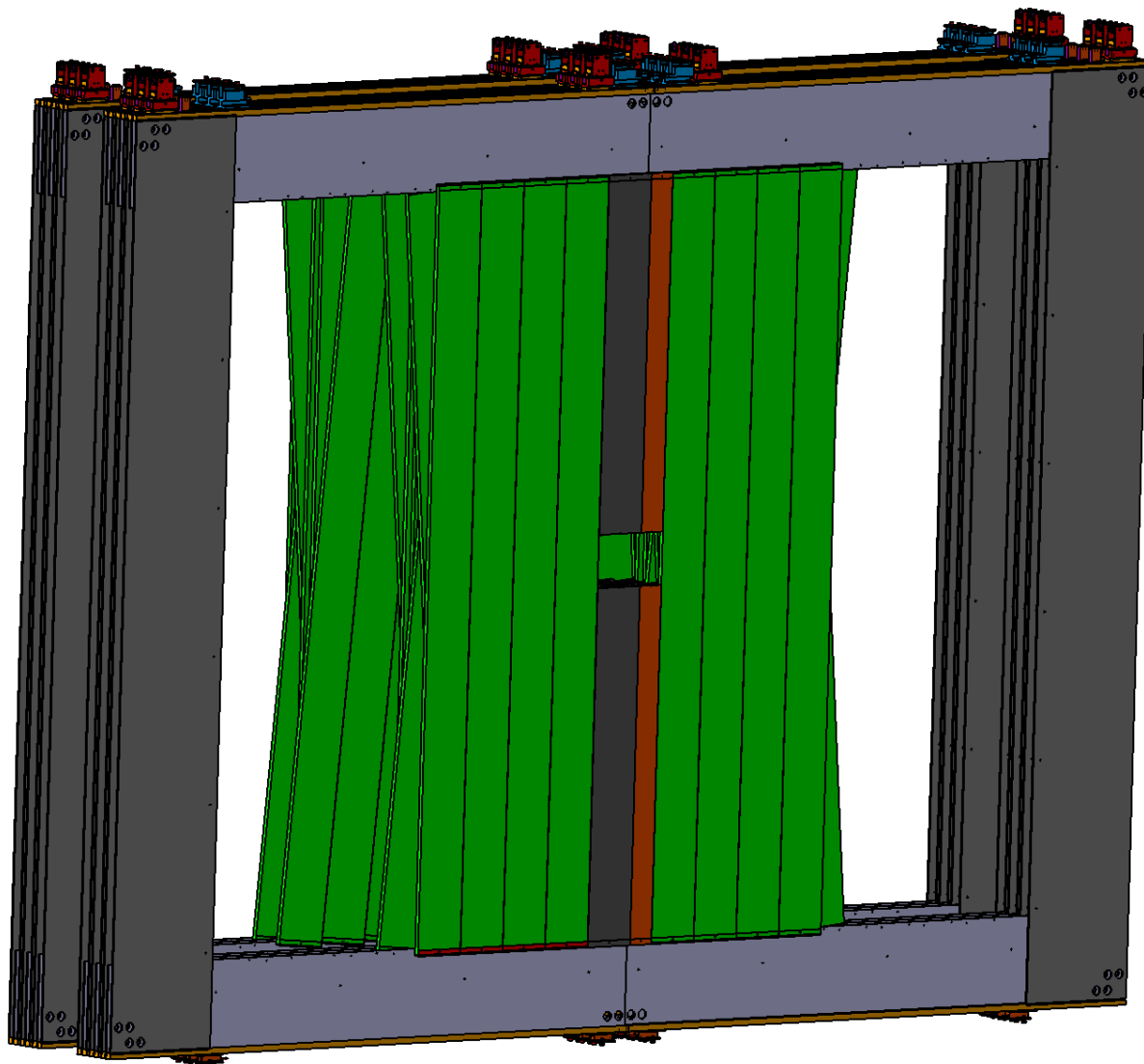

Contents:

1. General overview
2. First design of MUST support frame
3. MUST transport from GSI to FAIR
possible solutions:
 - a) Transport via LHCb transport frame
 - b) Transport of individual C-frames via trolleys
 - c) Transport by MUST support frame
 - d) ...
4. Advanced design of MUST support frame including absorber 5
5. Open items and next steps

1. General overview

- The MUST detector will consist of 12 C frames and will be divided in two stations.

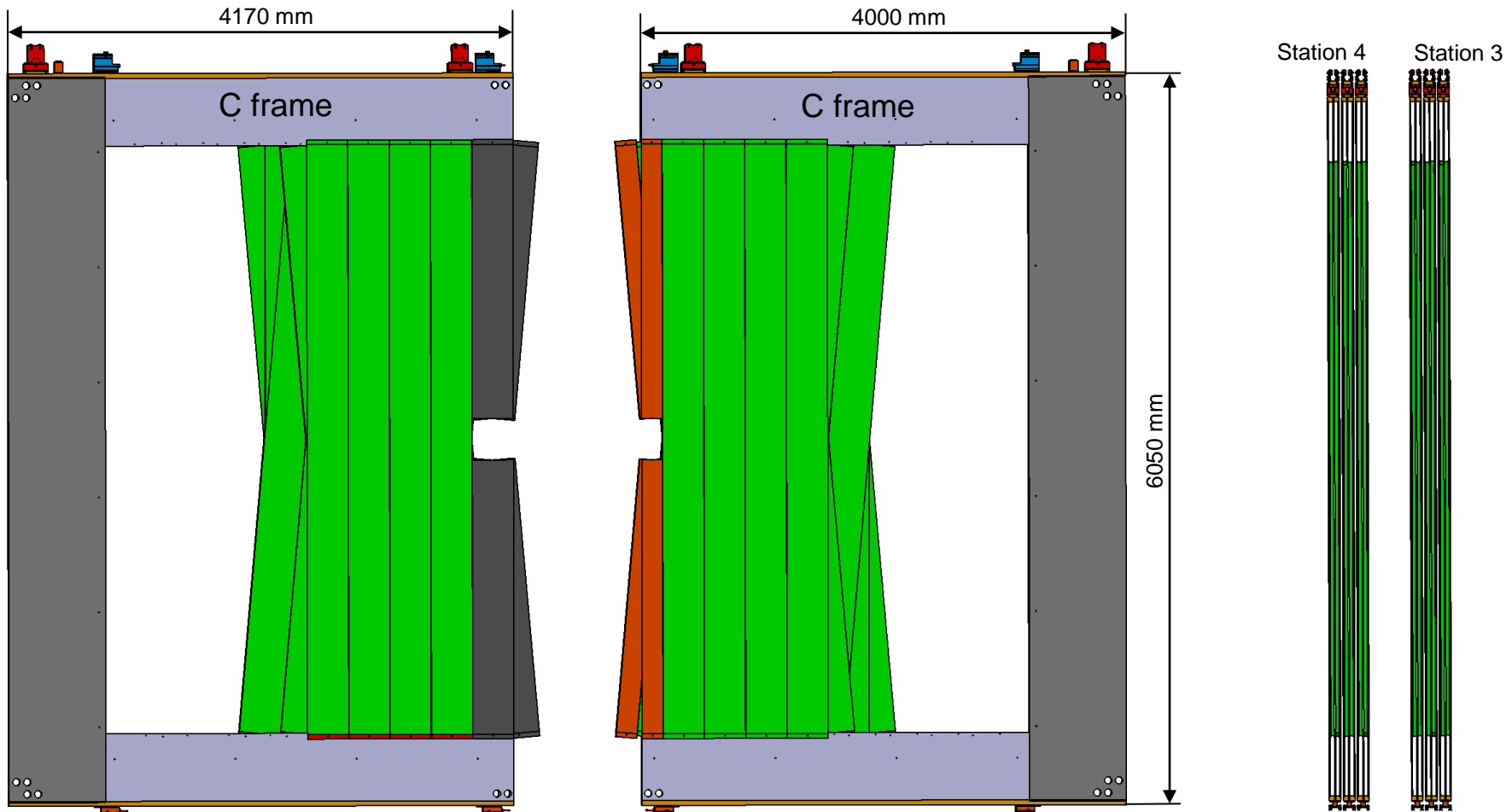

1. General overview

- Each station consists of 6 C frames, 3 to the left and right of the beam axis. The position of modules are well defined via pin holes in the C frame.

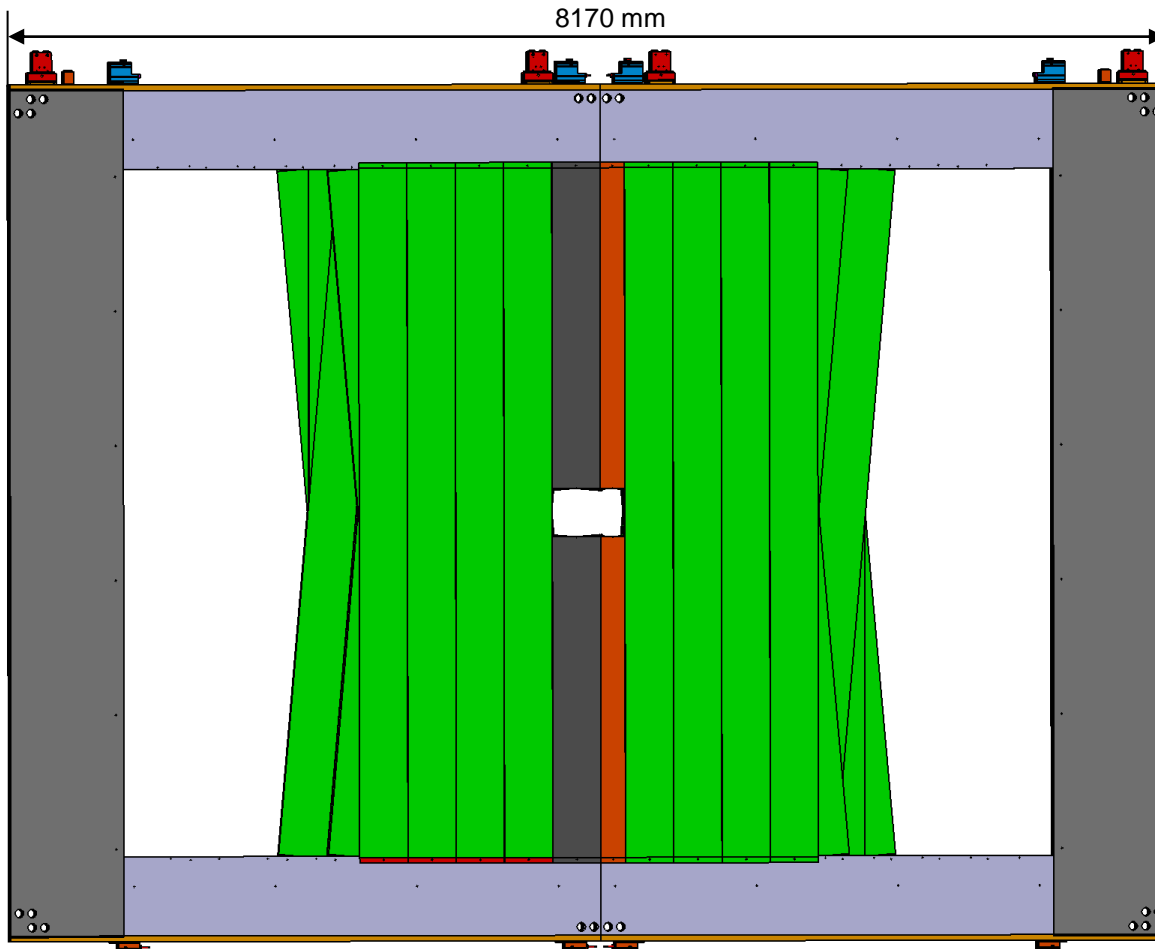

Module type F



Module type S1



Module type S3



1. General overview

- The gap between the C frames is 20 mm, the distance between C frames and absorber are 30 mm

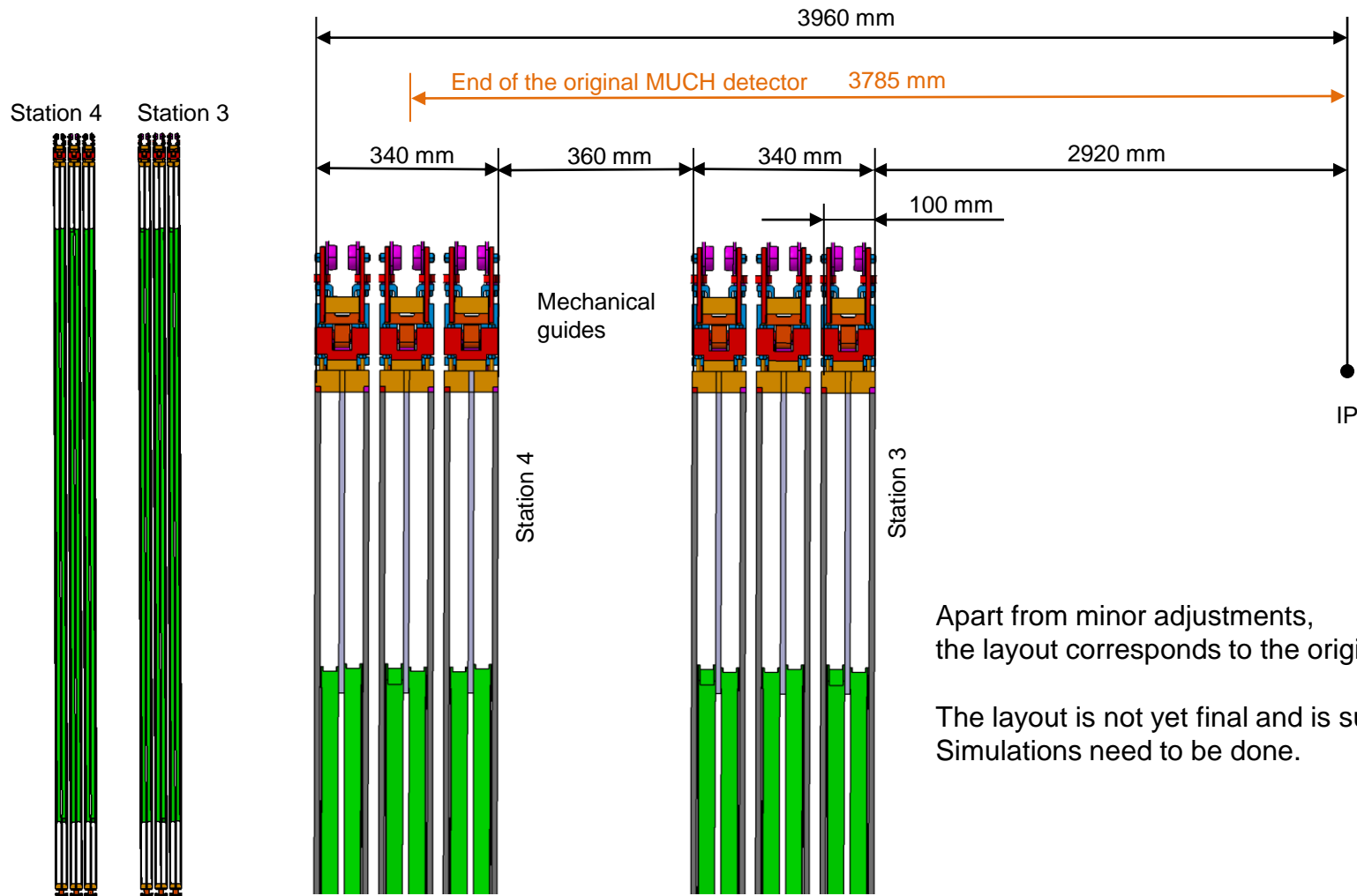

Apart from minor adjustments, the layout corresponds to the original MUCH layout.

The layout is not yet final and is subject to change. Simulations need to be done.

2. First design of MUST support frame

Requirements:

- The support frame must carry the C frames.
- The design must prevent the absorbers from tipping over, even in the event of seismic activity.
- The frame must be compatible with the existing C-frame guides.

Supplementary:

- Because the outer tracker transport frame is probably too large for the gate of the CBM hall, optionally, the holding structure could also serve as a transport device for the C-frames.

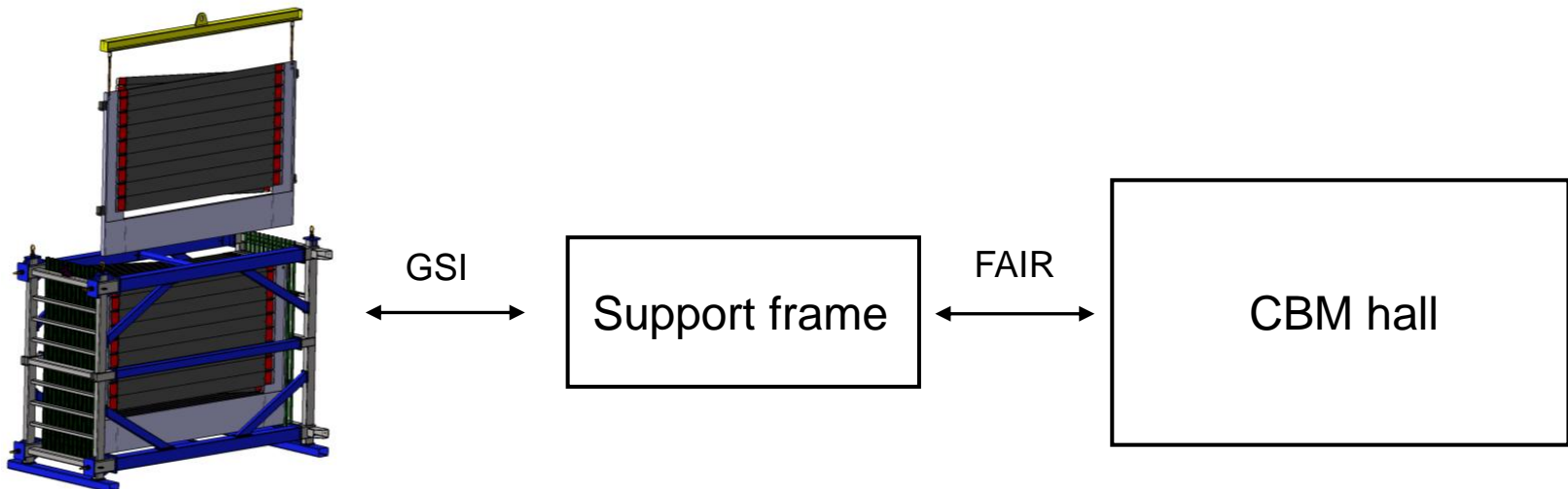

2. First design of MUST support frame

Proposal and first design:

- The support frame is divided in two similar structures, left and right of the beam axis.
- The left part carries the left frames of station 3 and 4, the other part the right frames of station 3 and 4.

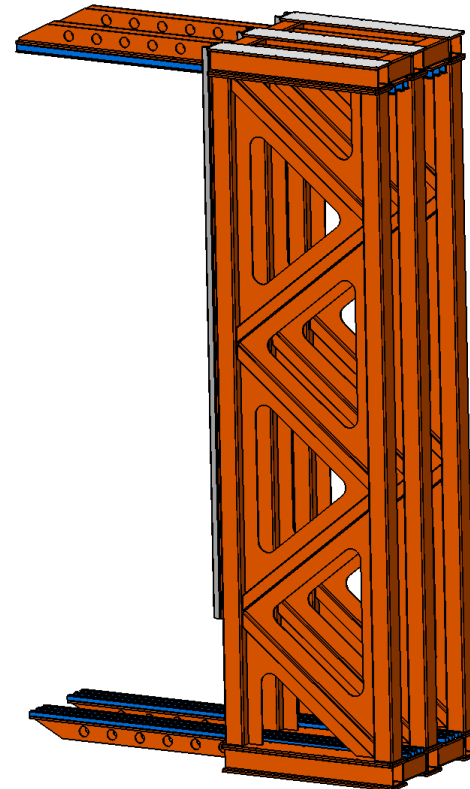
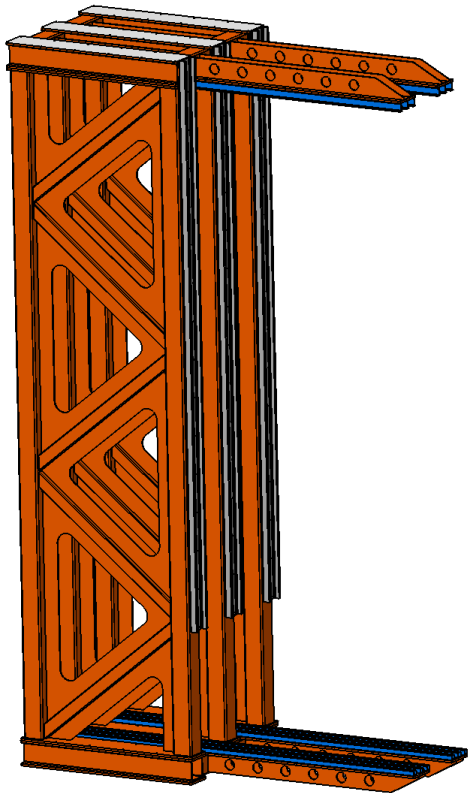

2. First design of MUST support frame

Proposal and first design:

- The support frame is divided in two similar structures, left and right of the beam axis.
- The left part carries the left frames of station 3 and 4, the other part the right frames of station 3 and 4.

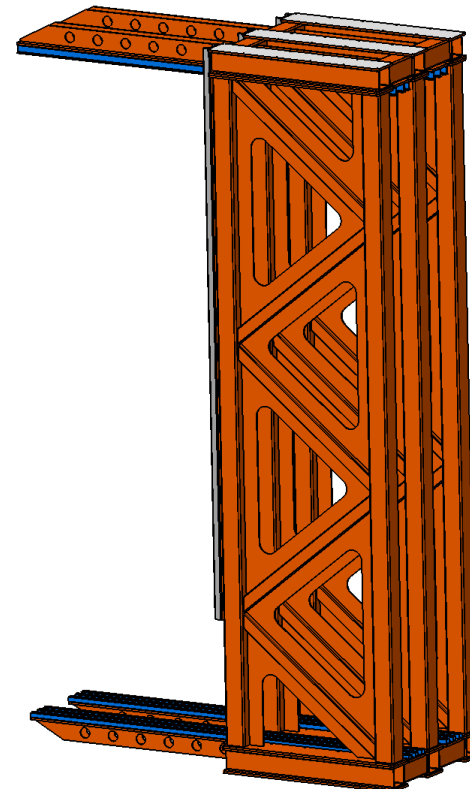
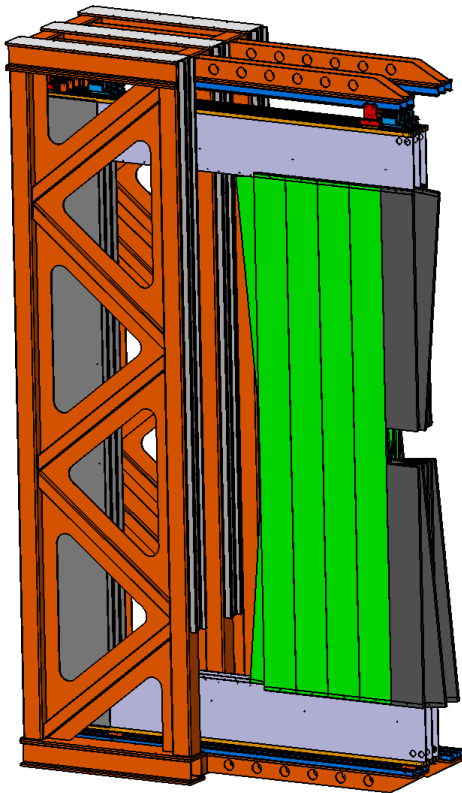

2. First design of MUST support frame

Proposal and first design:

- The support frame is divided in two similar structures, left and right of the beam axis.
- The left part carries the left frames of station 3 and 4, the other part the right frames of station 3 and 4.

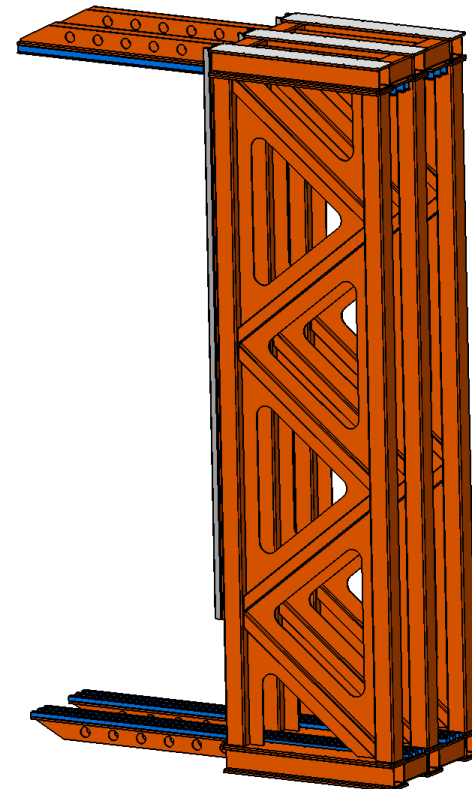
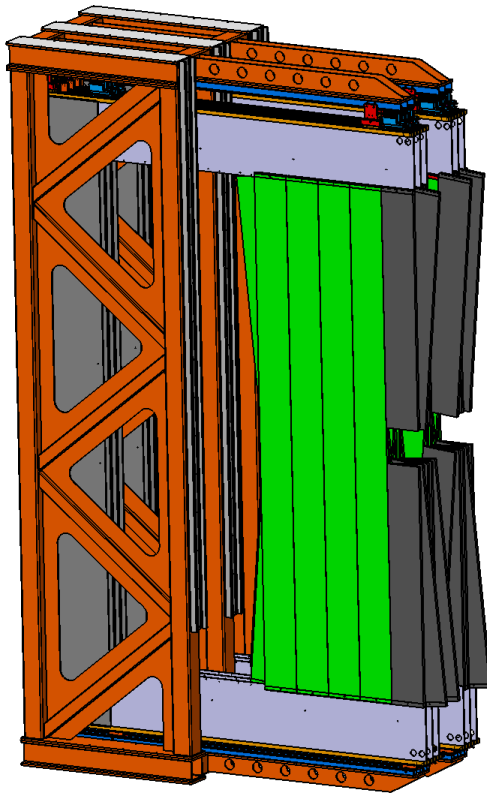

2. First design of MUST support frame

Proposal and first design:

- The support frame is divided in two similar structures, left and right of the beam axis.
- The left part carries the left frames of station 3 and 4, the other part the right frames of station 3 and 4.

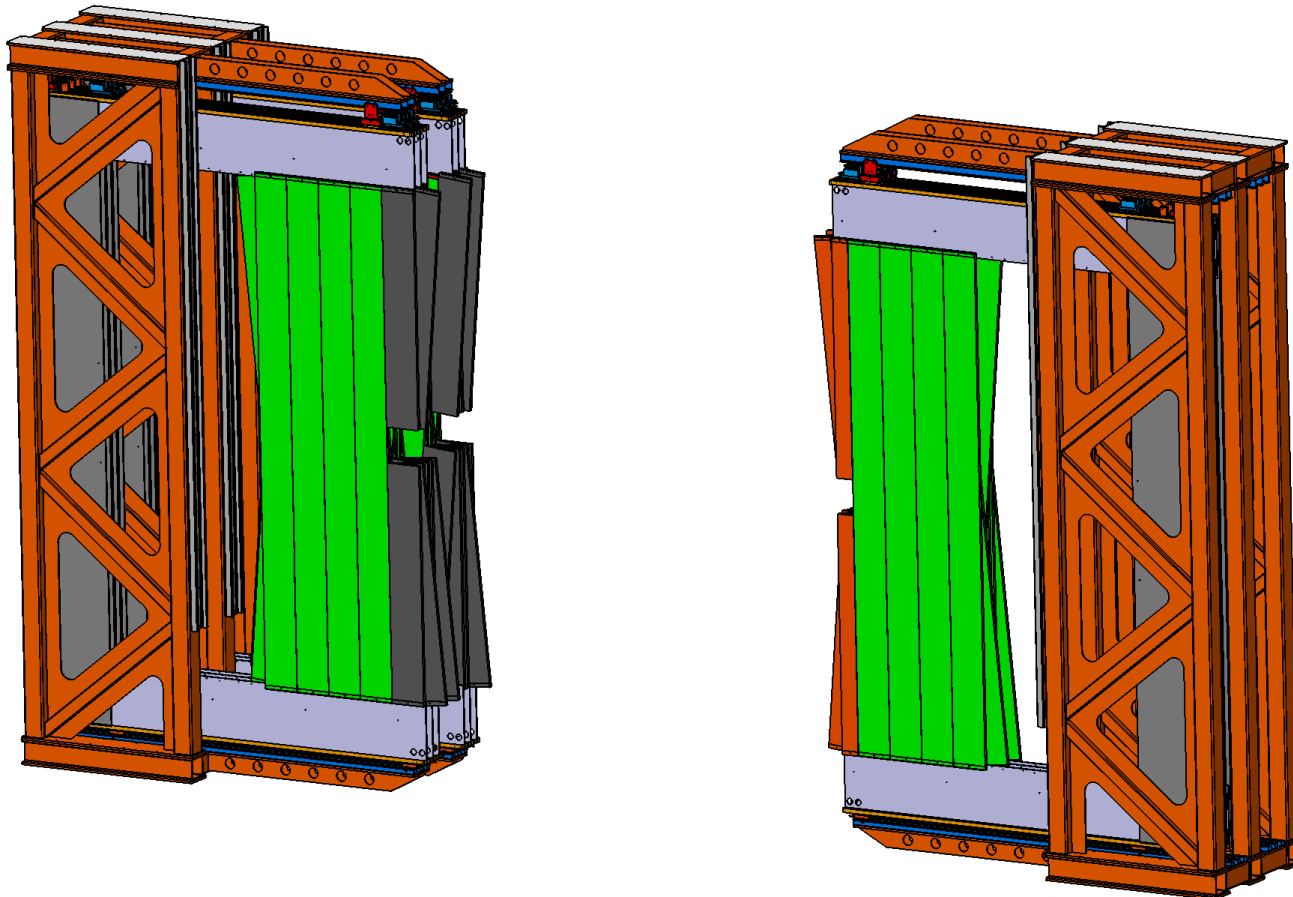

2. First design of MUST support frame

Proposal and first design:

- The support frame is divided in two similar structures, left and right of the beam axis.
- The left part carries the left frames of station 3 and 4, the other part the right frames of station 3 and 4.

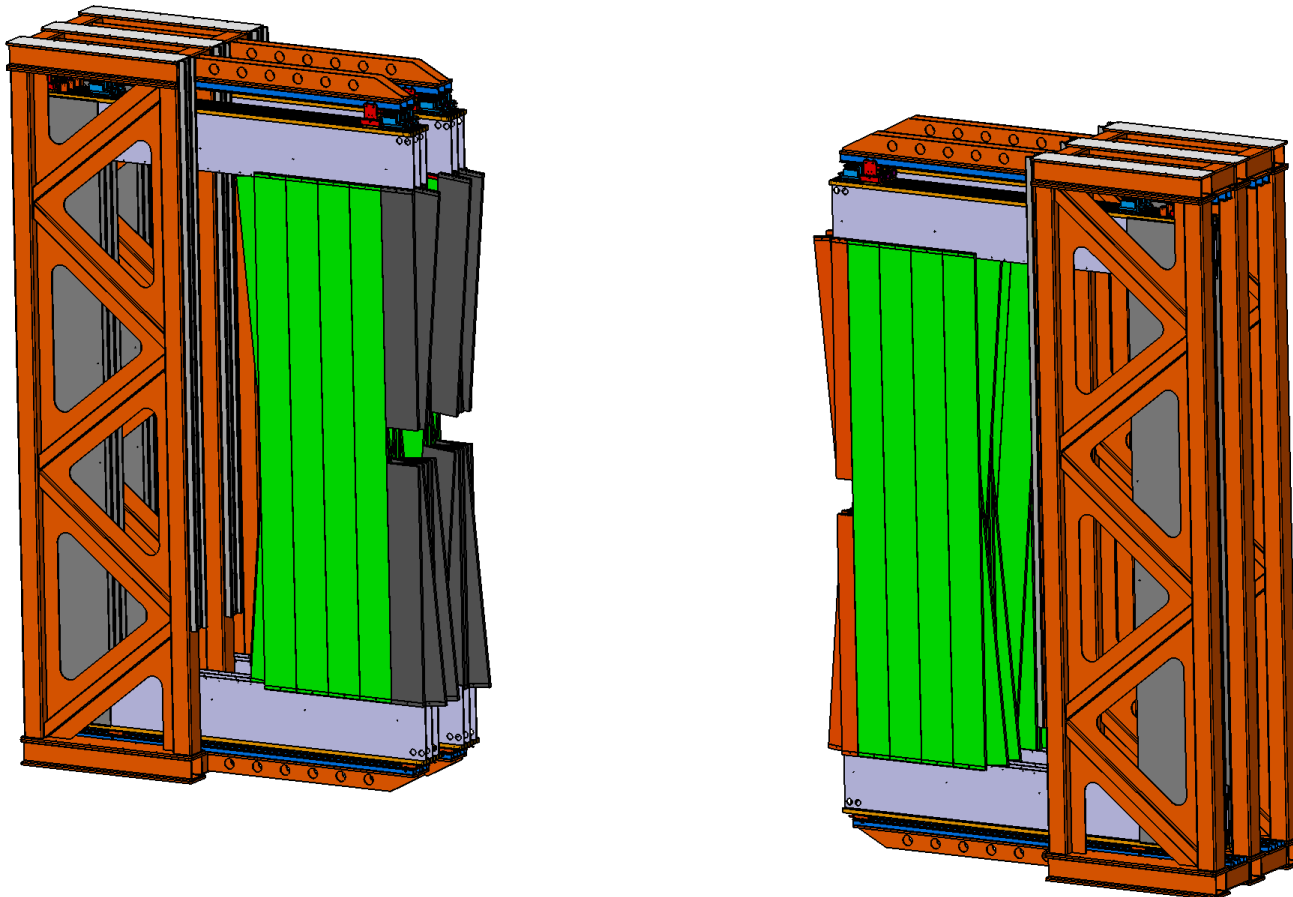

2. First design of MUST support frame

Proposal and first design:

- The support frame is divided in two similar structures, left and right of the beam axis.
- The left part carries the left frames of station 3 and 4, the other part the right frames of station 3 and 4.

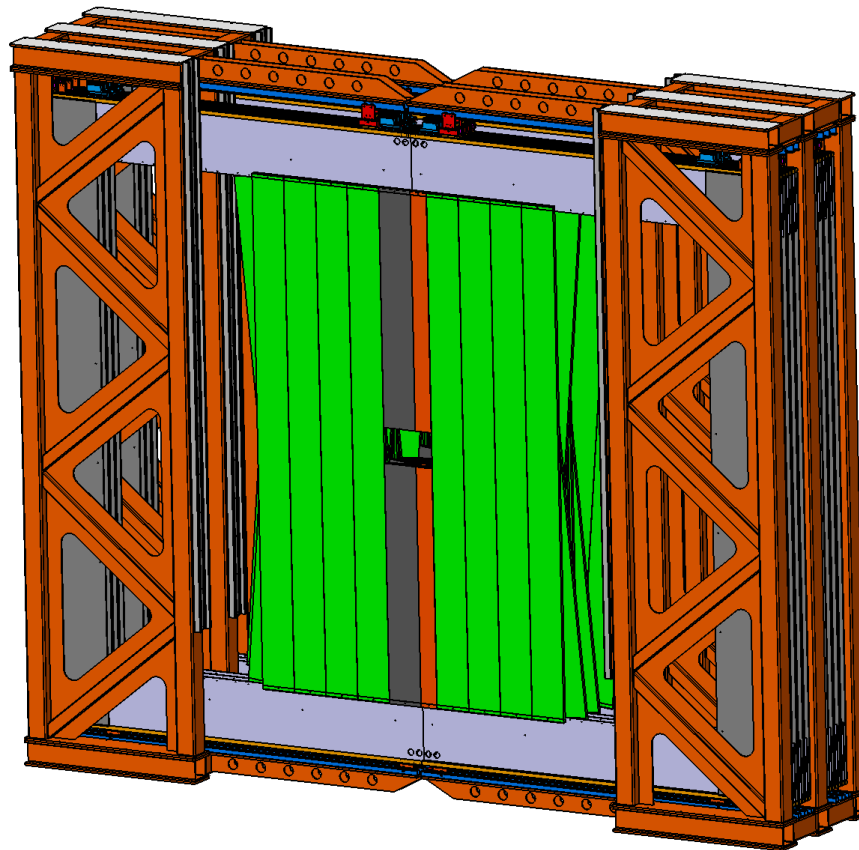

2. First design of MUST support frame

Proposal and first design:

- For guiding the C frames we used the same profiles and roller as at LHCb.
- The Roller are already attached to the C frames.

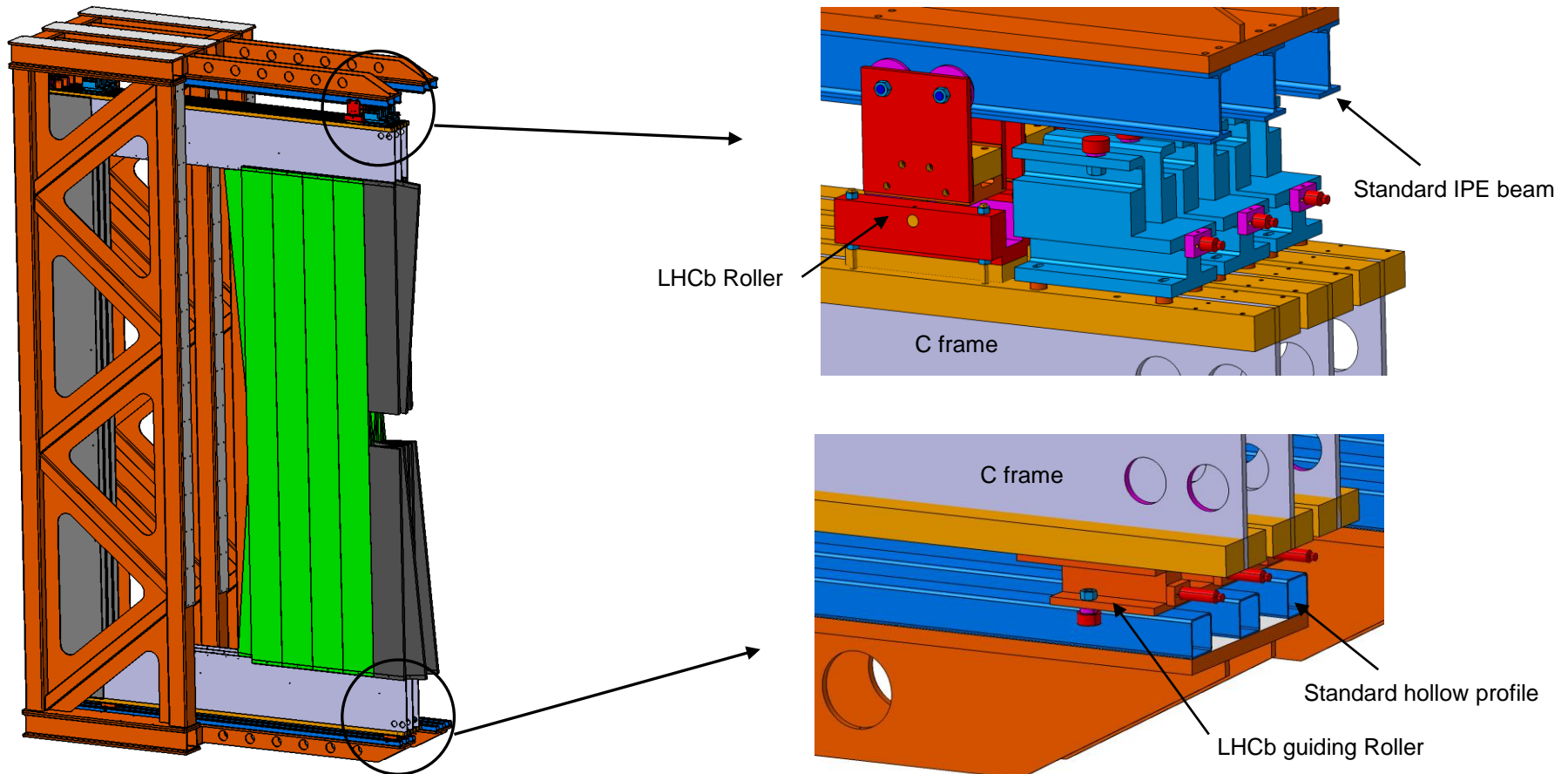

2. First design of MUST support frame

Proposal and first design:

- The design is configured so that the C-frames can be removed laterally at any time.

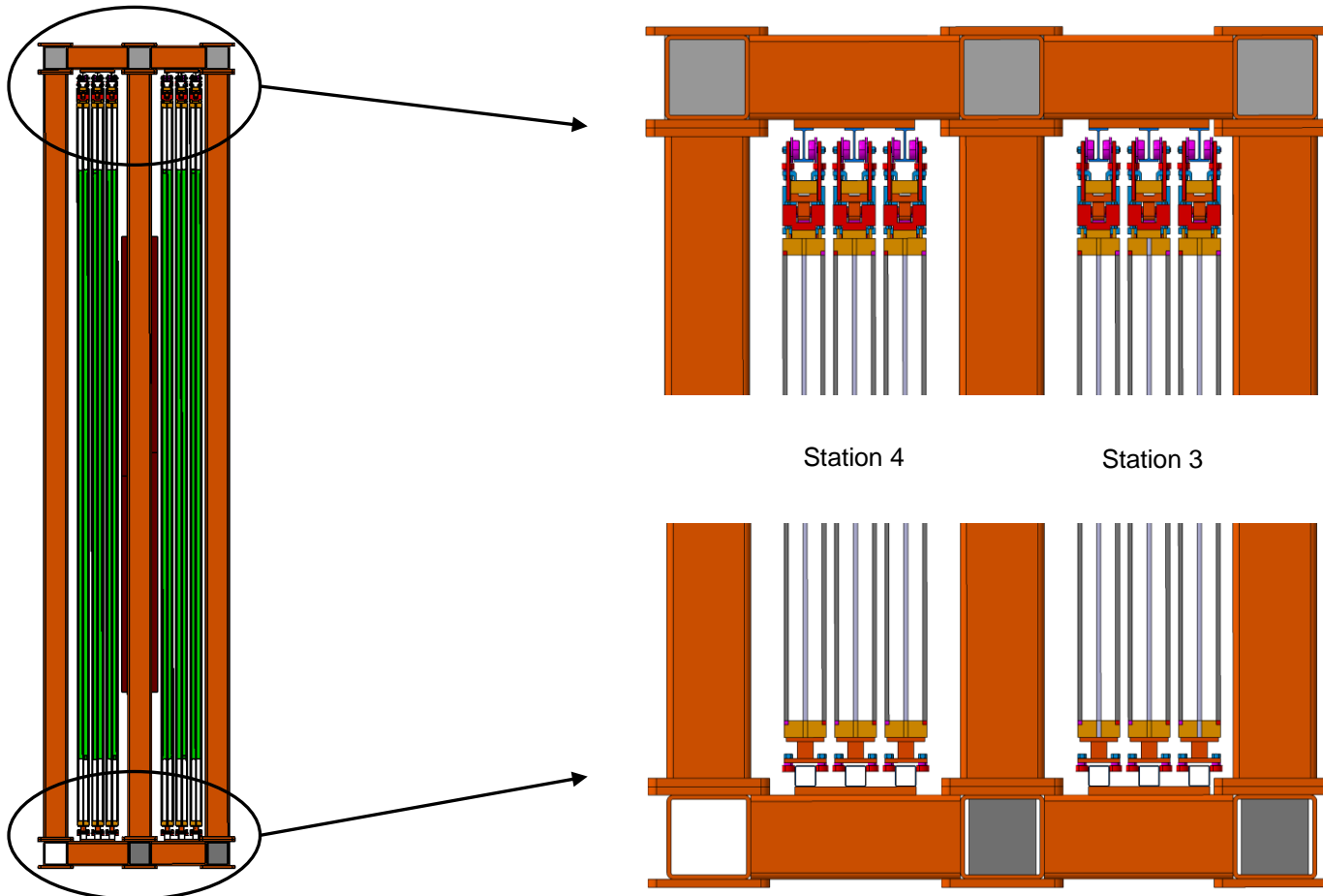

2. First design of MUST support frame

- The two similar structures themselves consist of various welded assemblies.

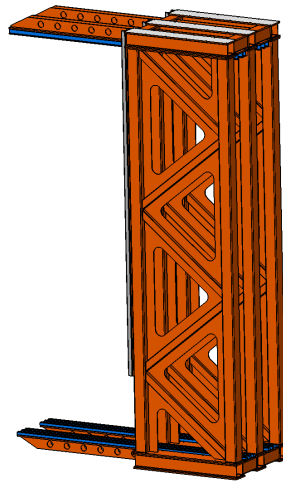
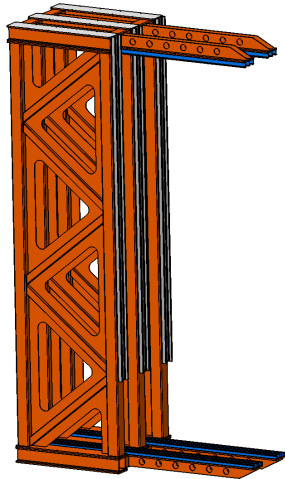

1 x base platform
bottom

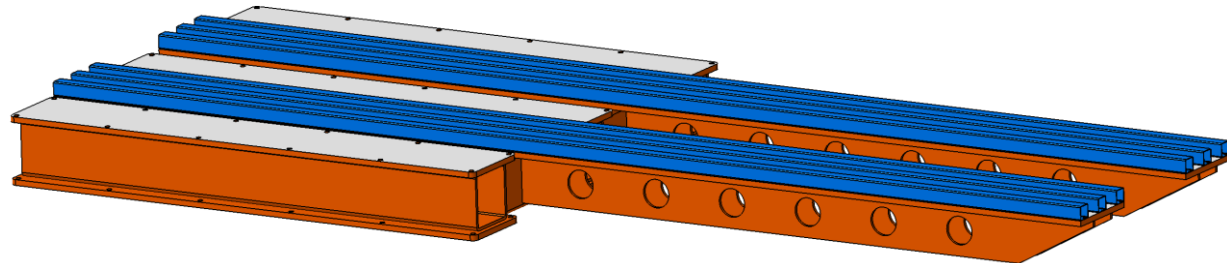
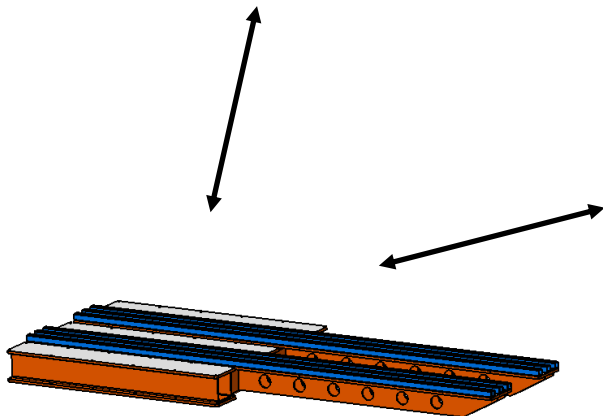

2. First design of MUST support frame

- The two similar structures themselves consist of various welded assemblies.

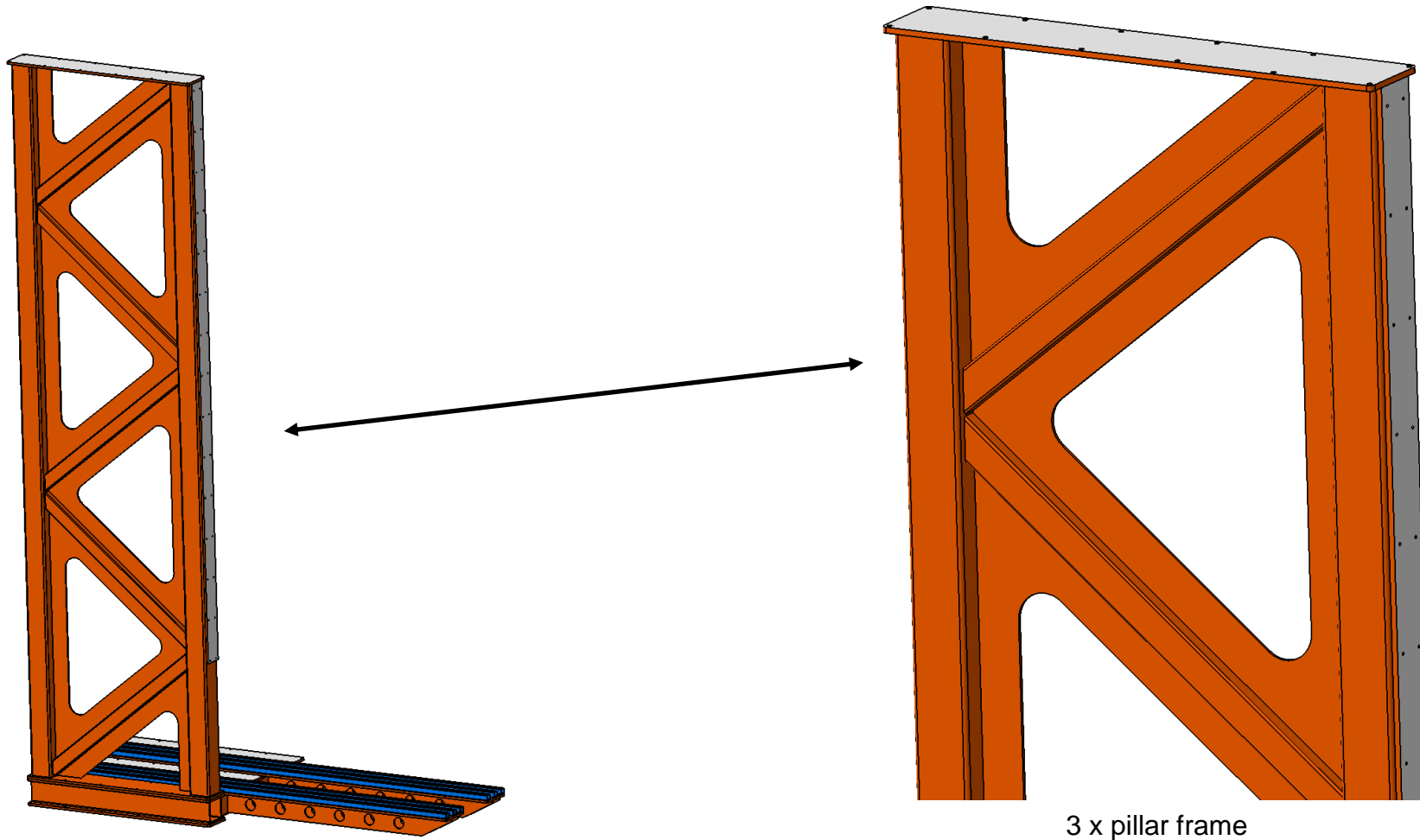

2. First design of MUST support frame

- The two similar structures themselves consist of various welded assemblies.

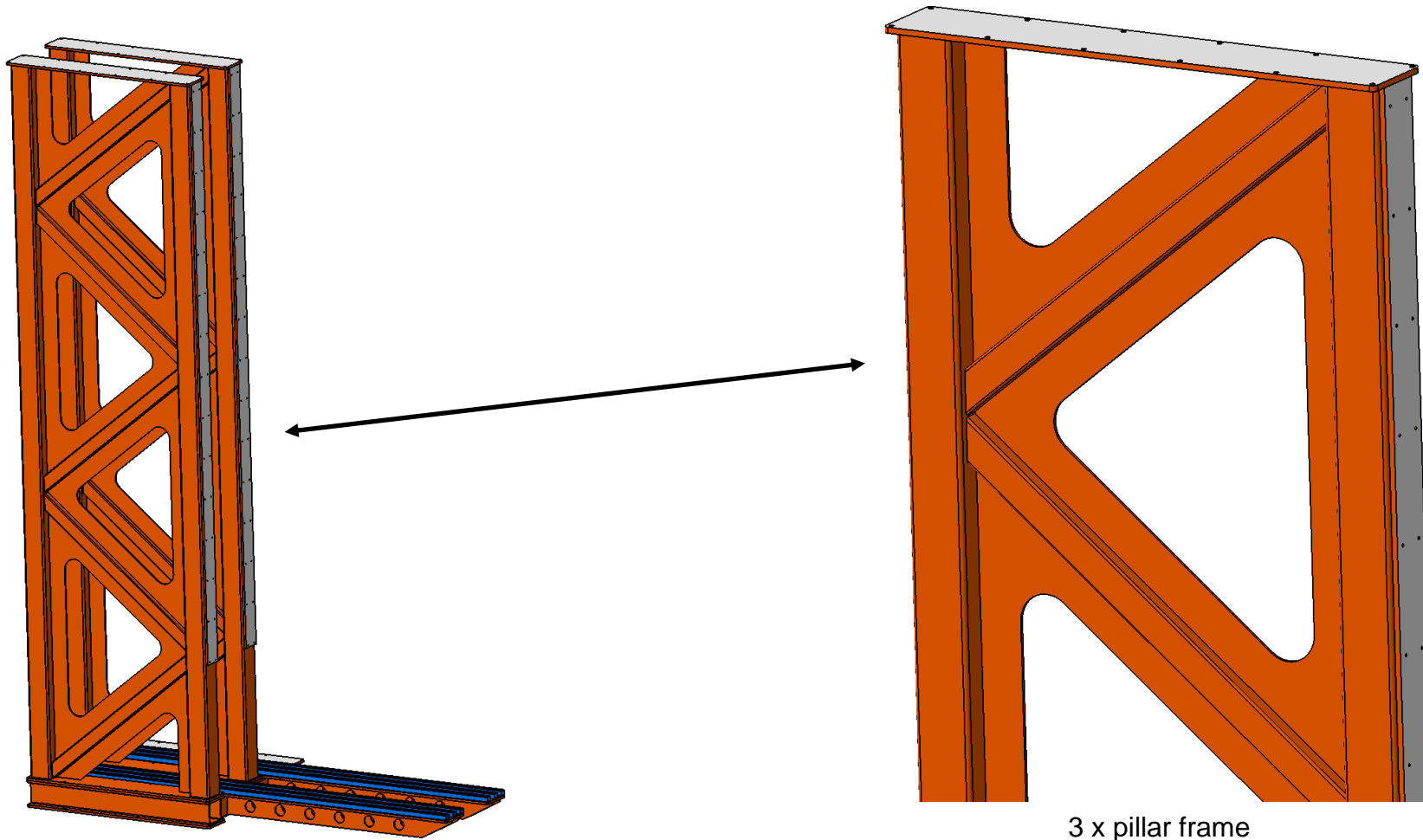

3 x pillar frame

2. First design of MUST support frame

- The two similar structures themselves consist of various welded assemblies.

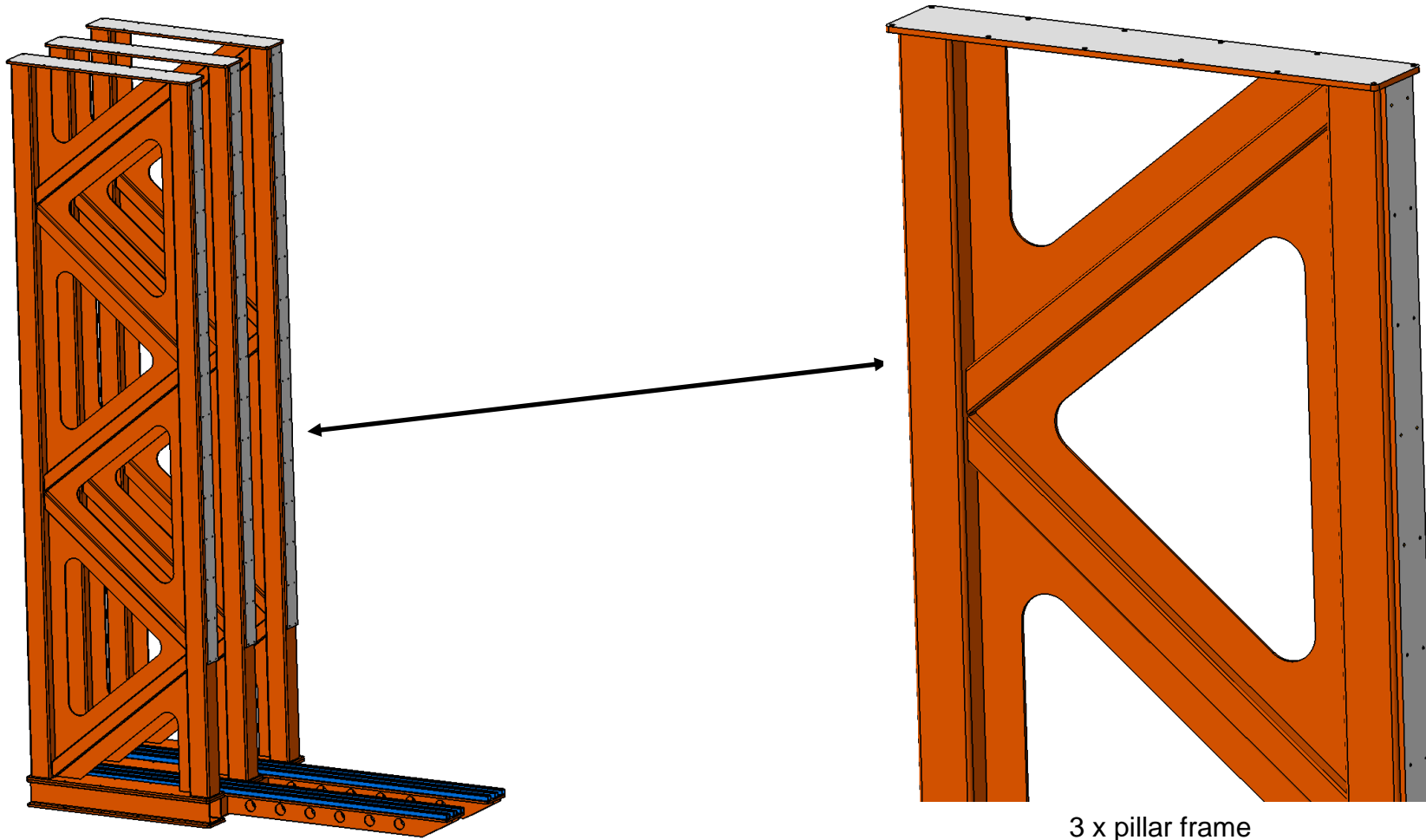

2. First design of MUST support frame

- The two similar structures themselves consist of various welded assemblies.

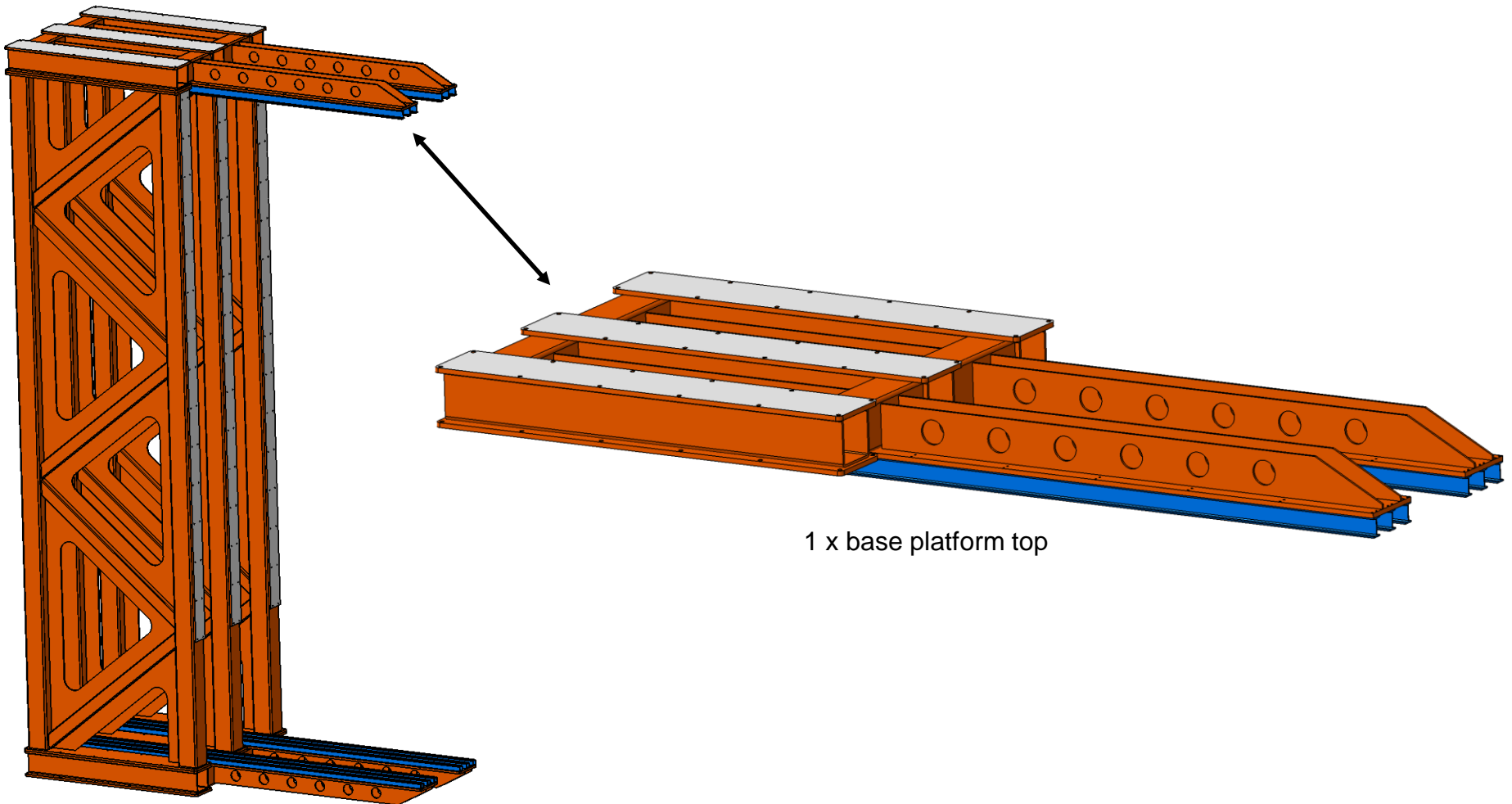

2. First design of MUST support frame

- The two similar structures themselves consist of various welded assemblies.

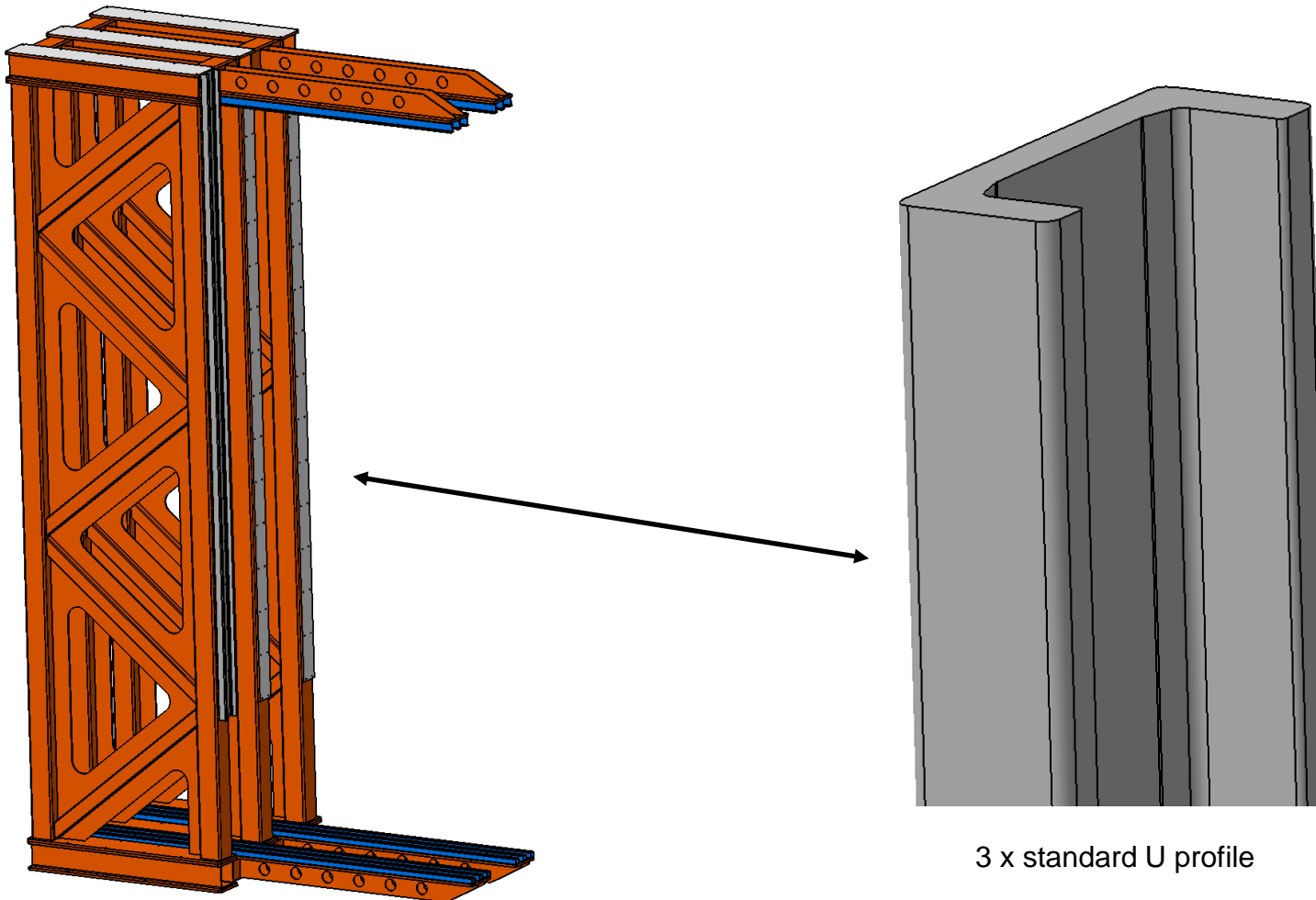

2. First design of MUST support frame

- The two similar structures themselves consist of various welded assemblies.

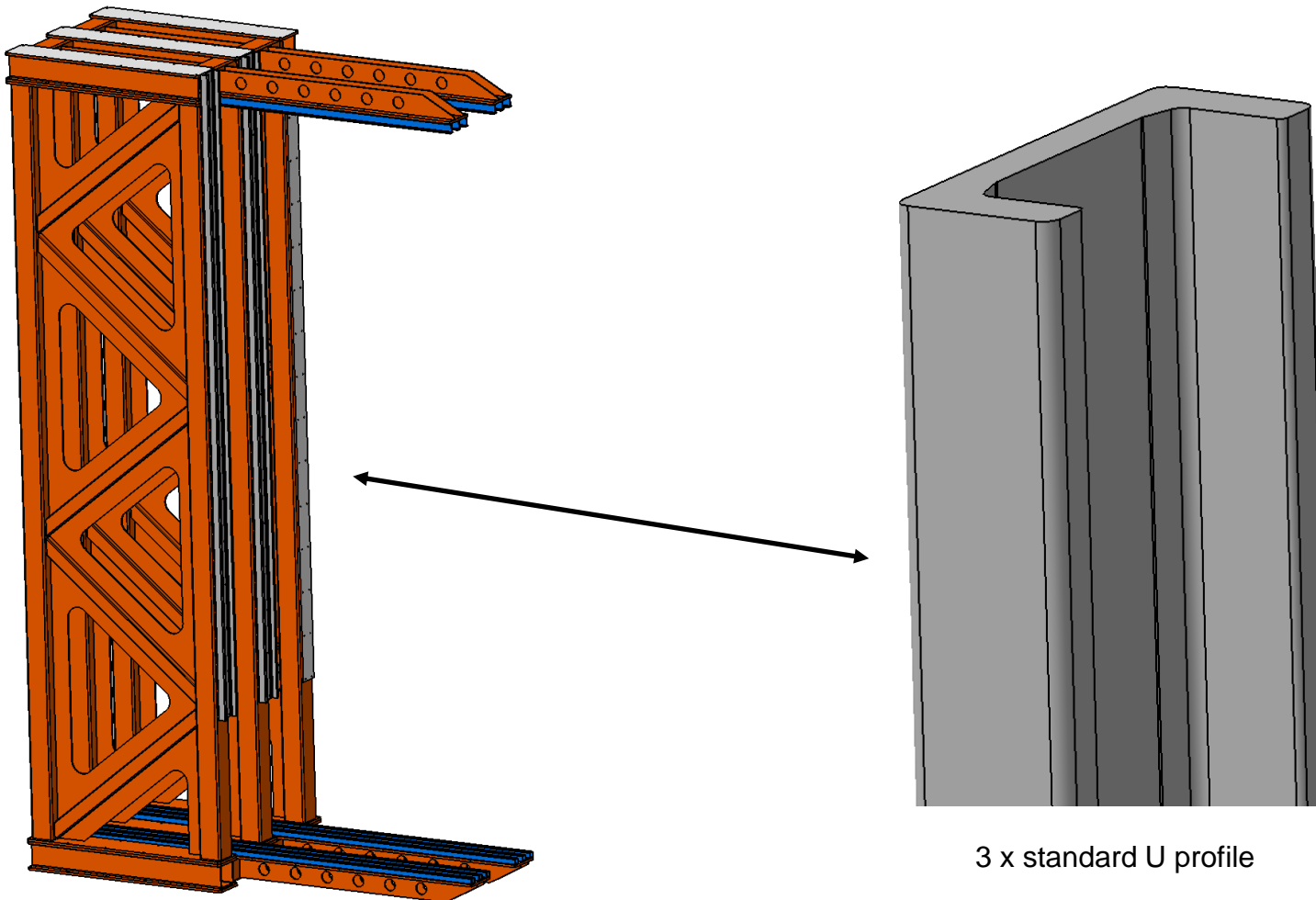

2. First design of MUST support frame

- The two similar structures themselves consist of various welded assemblies.

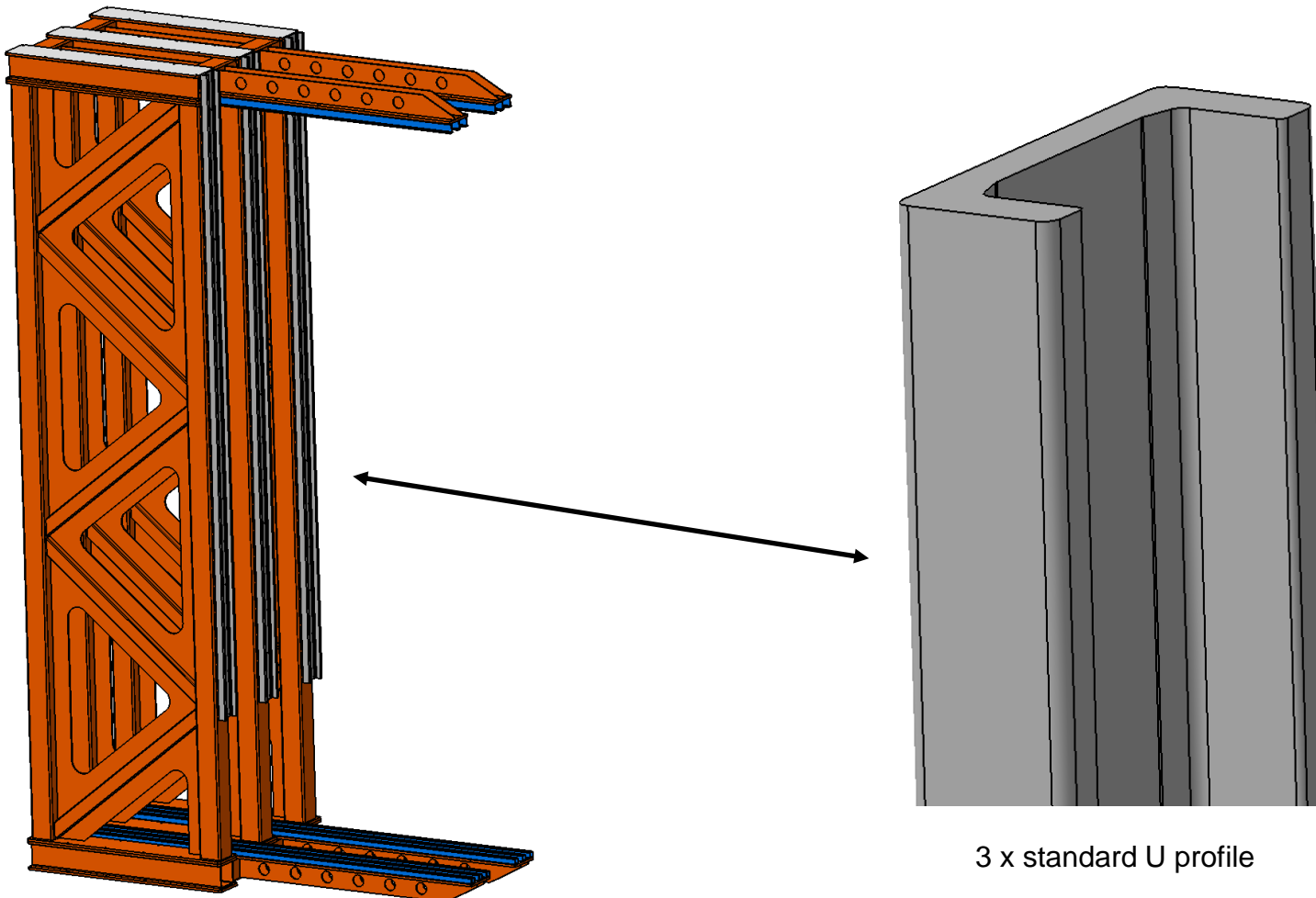

2. First design of MUST support frame

- The standard U-profiles serve to guide and horizontally secure the absorbers via Roller.
- This allows the absorbers to be installed and removed independently, without endangering the C-frames.
- The geometry of the absorbers corresponds to the original MUCH layout.

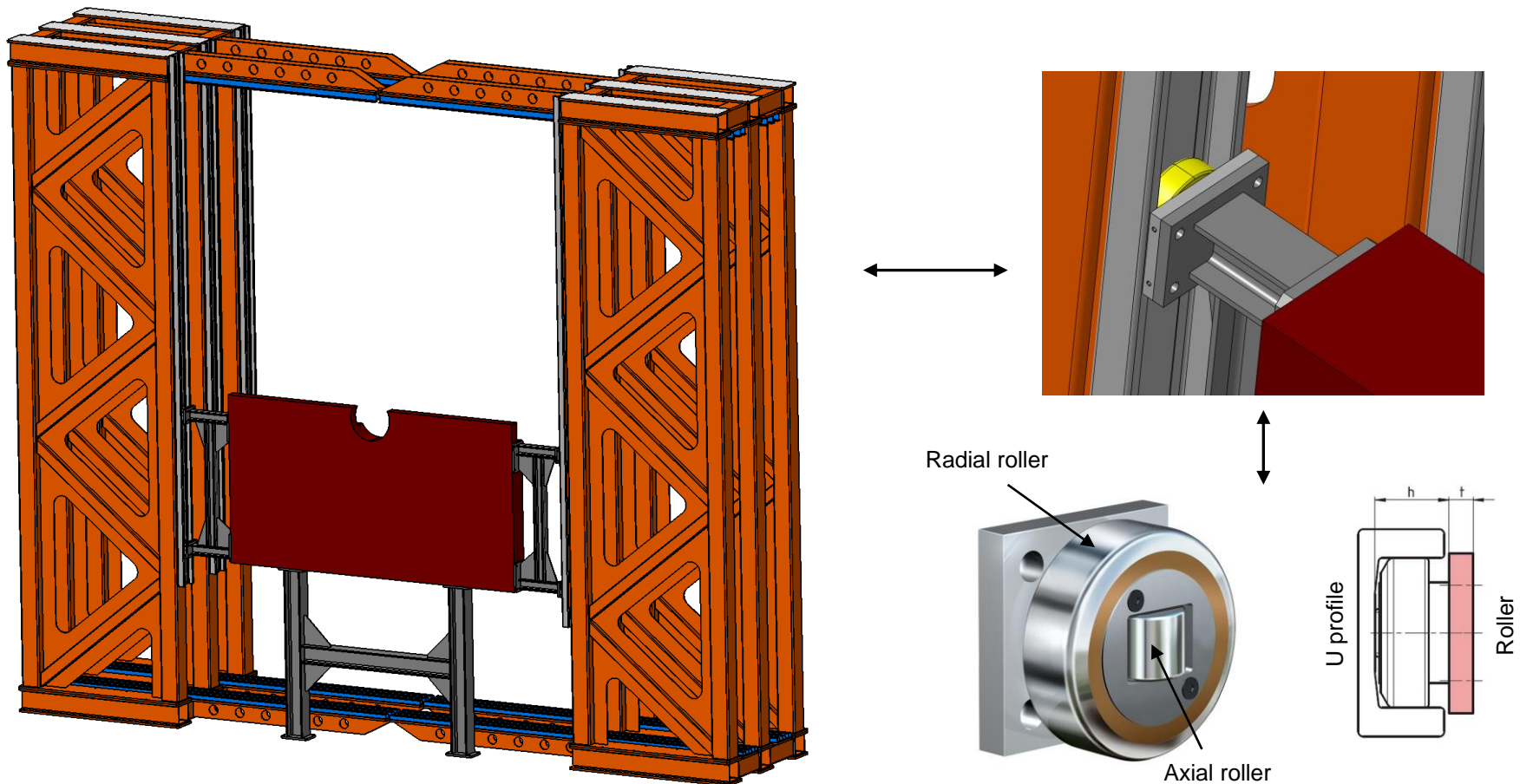

2. First design of MUST support frame

- The standard U-profiles serve to guide and horizontally secure the absorbers via Roller.
- This allows the absorbers to be installed and removed independently, without endangering the C-frames.
- The geometry of the absorbers corresponds to the original MUCH design.

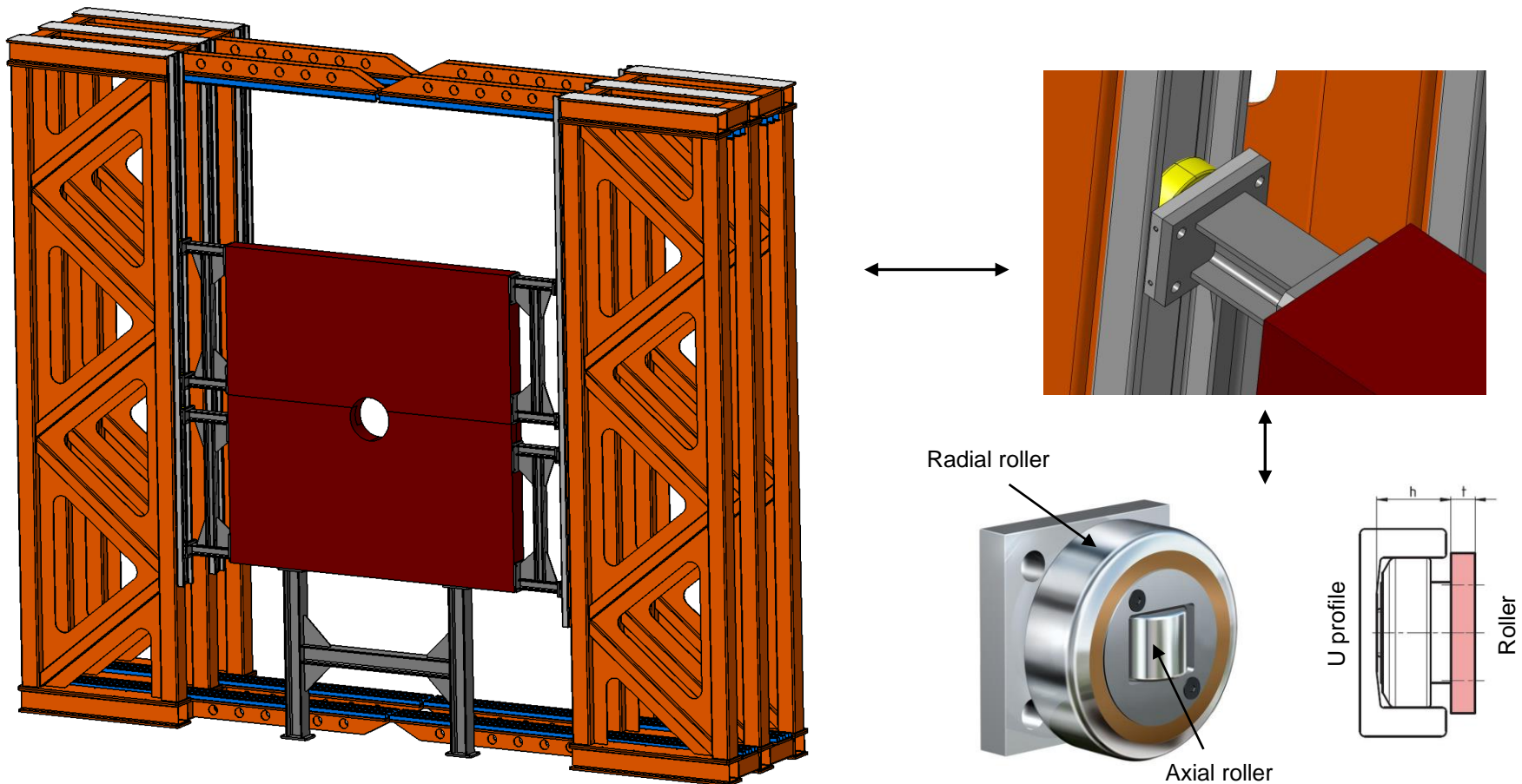

2. First design of MUST support frame

- The standard U-profiles serve to guide and horizontally secure the absorbers via Roller.
- This allows the absorbers to be installed and removed independently, without endangering the C-frames.
- The geometry of the absorbers corresponds to the original MUCH design.

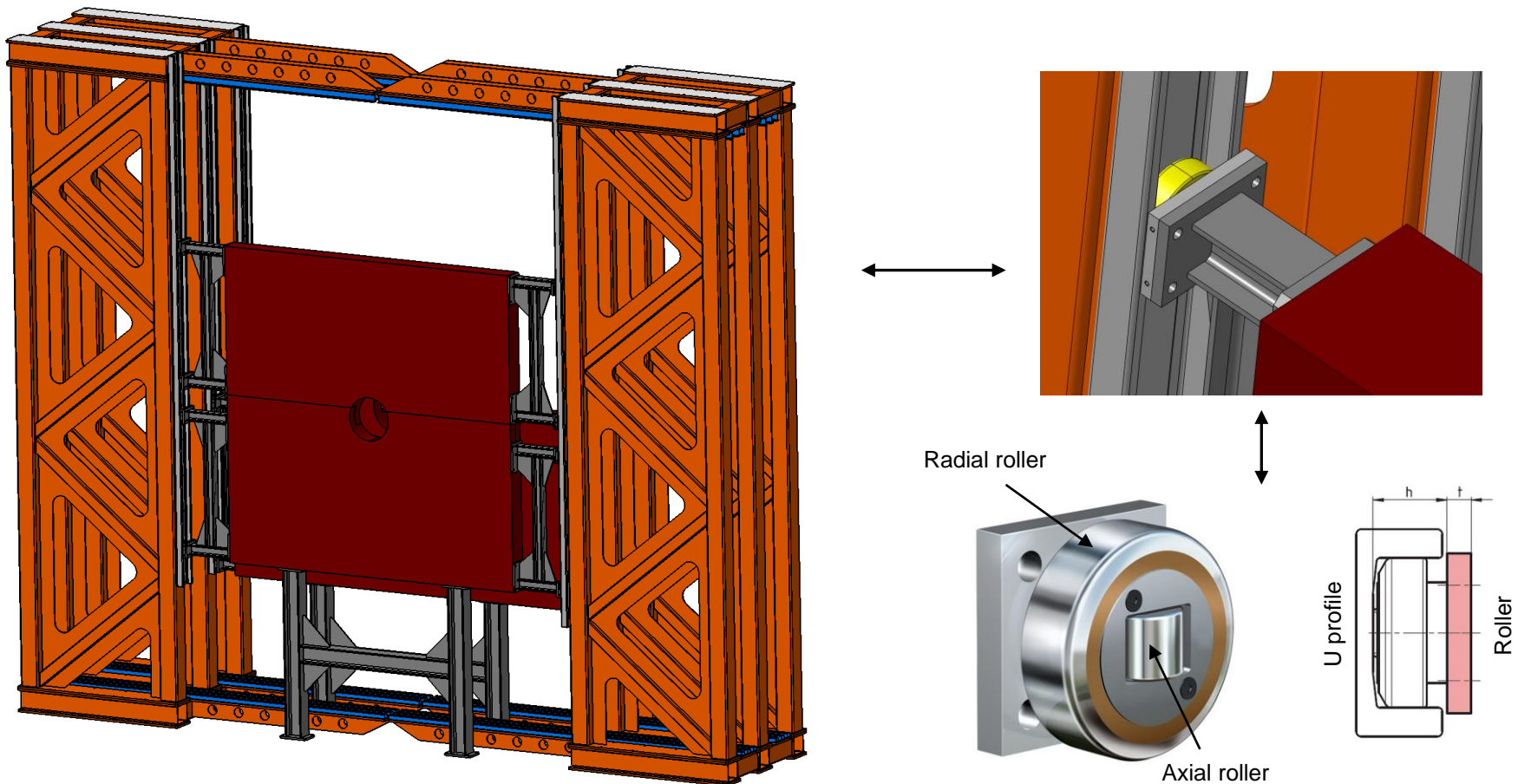

2. First design of MUST support frame

- The standard U-profiles serve to guide and horizontally secure the absorbers via Roller.
- This allows the absorbers to be installed and removed independently, without endangering the C-frames.
- The geometry of the absorbers corresponds to the original MUCH design.

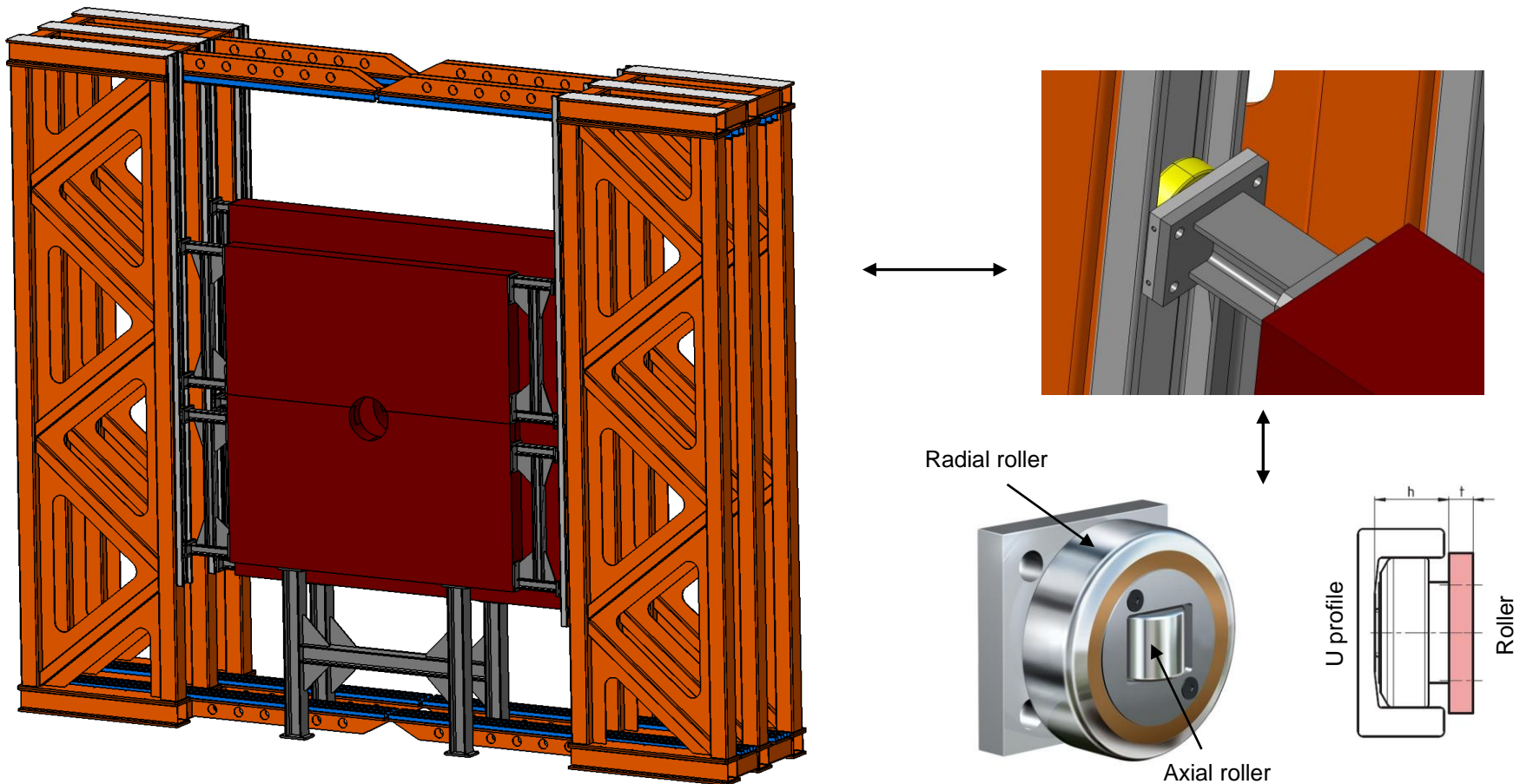

2. First design of MUST support frame

- While the horizontal forces are absorbed by the support frame, the main load is transferred to the lower CBM infrastructure via supports on the lower absorber.

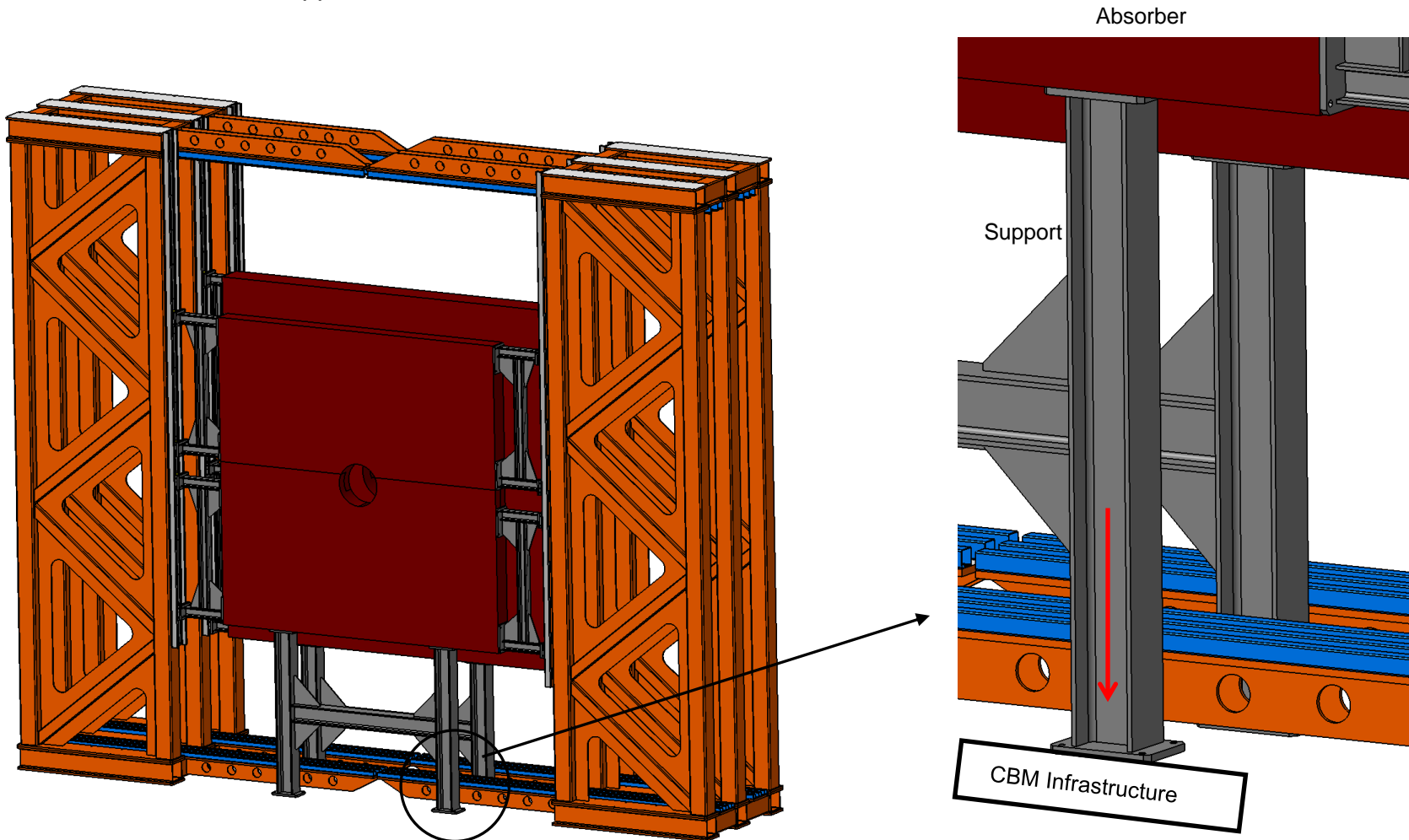

2. First design of MUST support frame

- The following table shows a rough cost estimate.

Item	Costs	Comment
Support frame MUST (Weight approx. 20 tons)		
Steel construction manufacturing	70.000 EUR	Made of structural steel S235
Guide elements and heavy-duty rollers	38.000 EUR	
Static calculation	4.000 EUR	
Transport and assembly	20.000 EUR	Screw connections, no welding
<u>Total costs</u>	<u>132.000 EUR</u>	

3. MUST transport from GSI to FAIR

a) Transport via LHCb OT transport frame

- The C frames are currently located within the LHCb OT transport frame in the BE42 hall at GSI.
- The easiest thing would be to transport the entire frame to the CBM Cave.
- However, the transport frame is relatively tall at 5.152 m and likely won't fit through the truck entrance.
- So the question is, can we somehow get the frame into the CBM cave?

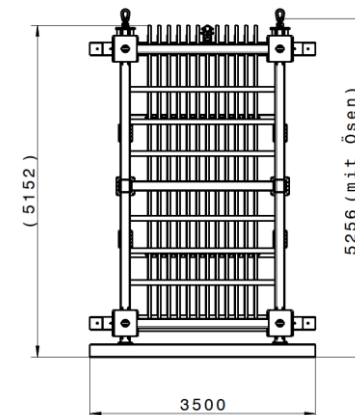
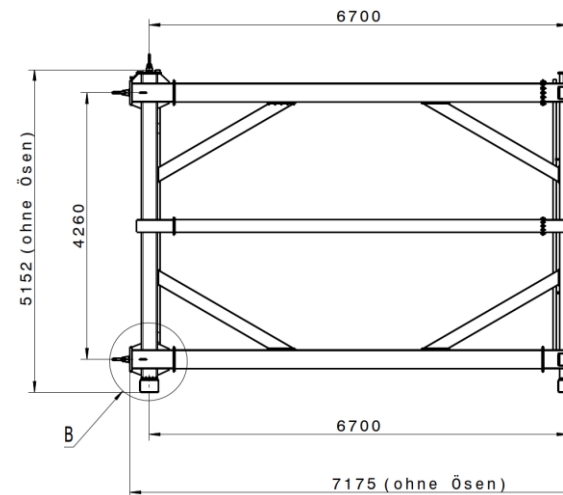
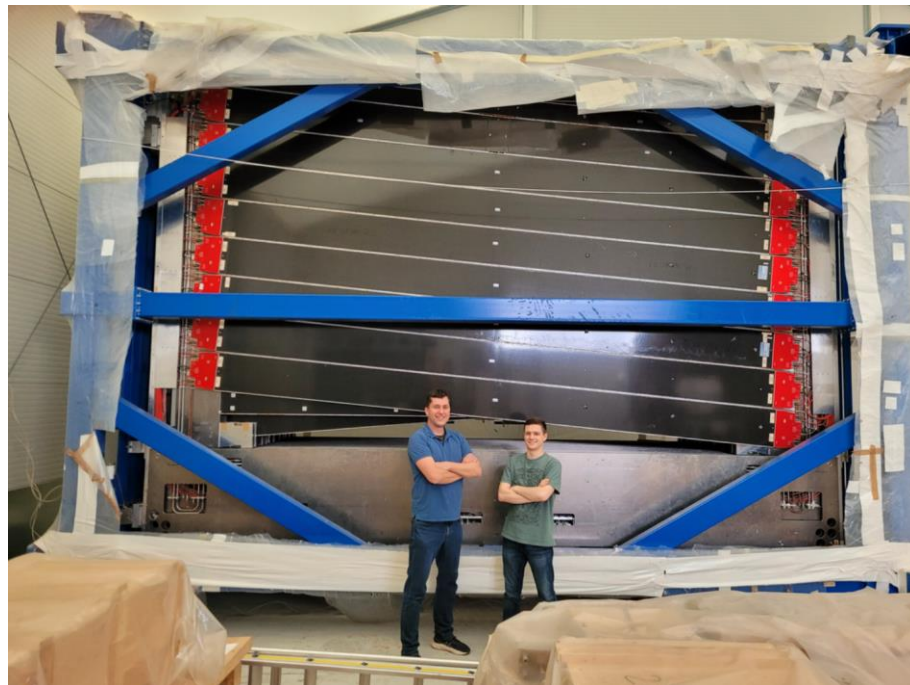

3. MUST transport from GSI to FAIR



b) Transport of individual C-frames via trolleys

- This short presentation shows two possible designs of trolleys for transporting and storing the C-frames of the LHCb Outer Tracker.
- For the main frame of the car we choose aluminum profiles from ITEM.
- These profiles allow a high degree of flexibility for later adjustments thanks to their groove system.
- Since the ITEM profile is very common at GSI, they can be dismantled and stored when they are no longer needed and reused later.
- An assembly of welded profiles would be tailor-made for this purpose and would have to be disposed of afterwards.
- For this reason, the use of ITEM profiles for this purpose, even if standard steel profiles, would be somewhat cheaper, has a financial and economic added value.

3. MUST transport from GSI to FAIR

1. The transport frame must be moved out of hall BE42.

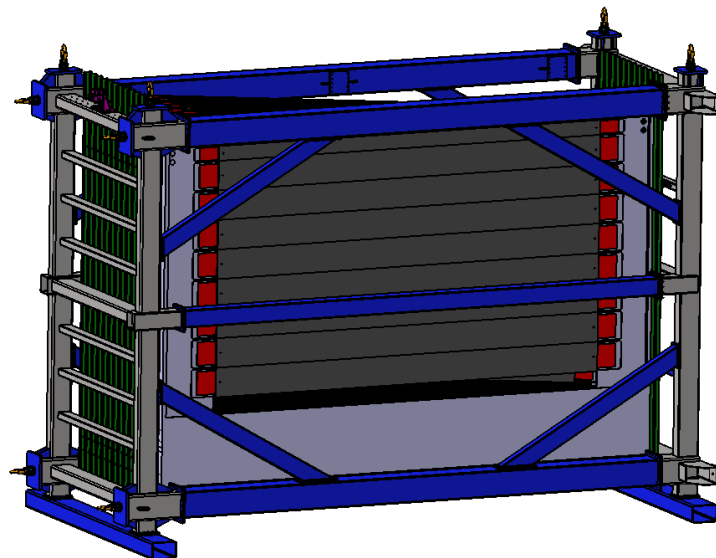

3. MUST transport from GSI to FAIR

2. A mobile crane and a suitable traverse are required.

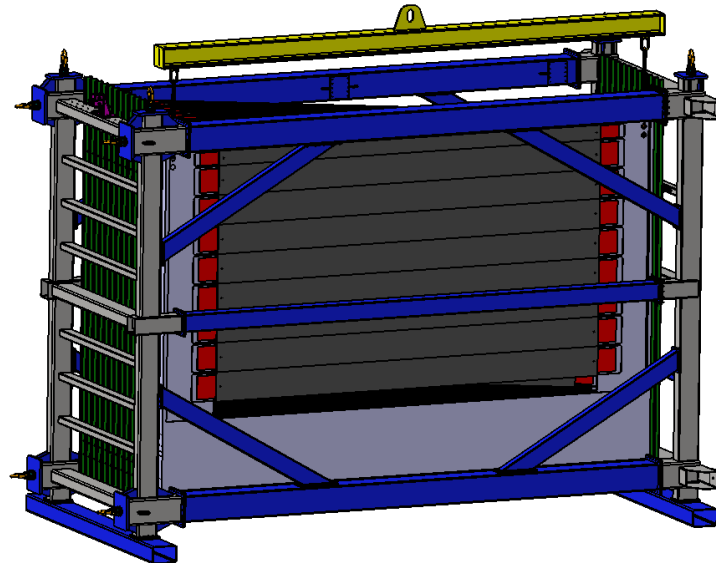

3. MUST transport from GSI to FAIR

3. The traverse is attached to existing holes in the C-frame and the C-frame is lifted out of the transport frame.

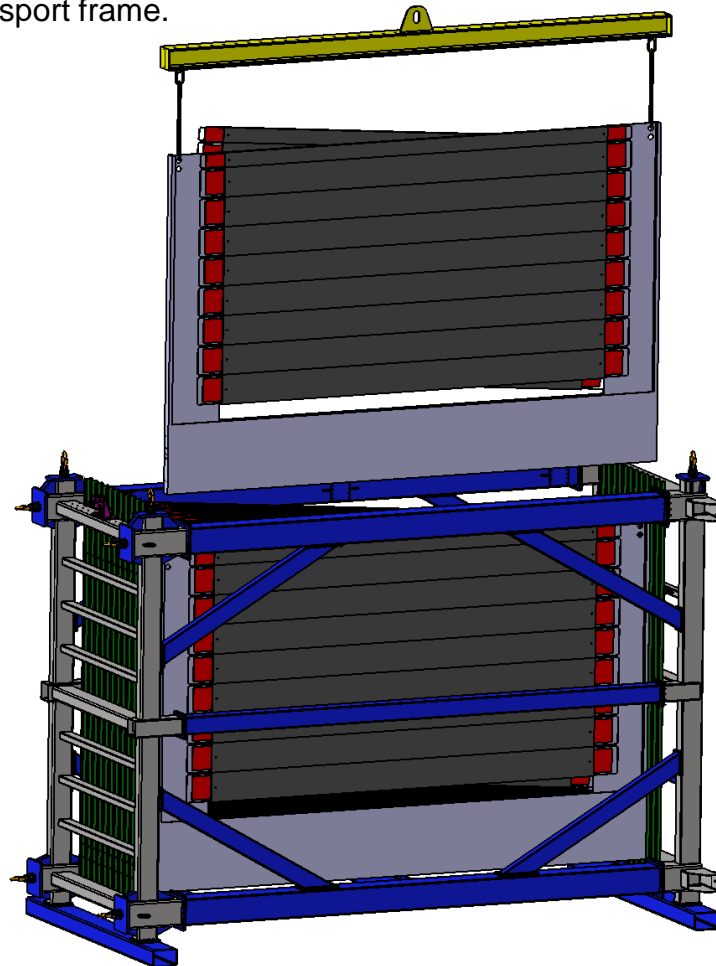

3. MUST transport from GSI to FAIR

4. The C-frame is lifted from the transport frame.

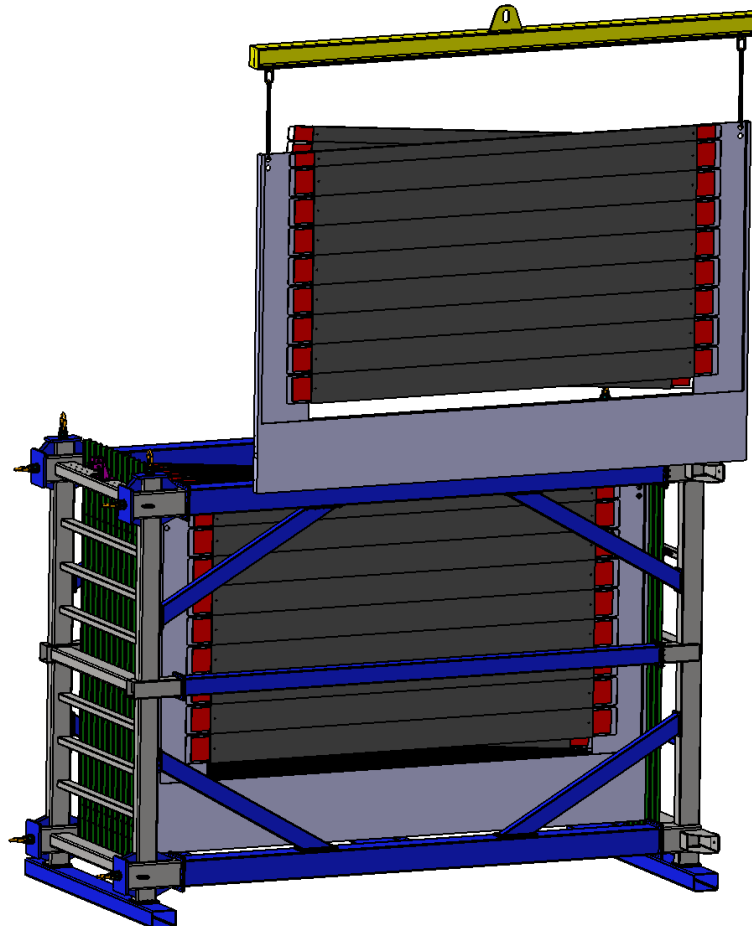

3. MUST transport from GSI to FAIR

5. The C-frame is lowered to just below the ground and special trolleys are brought into position.

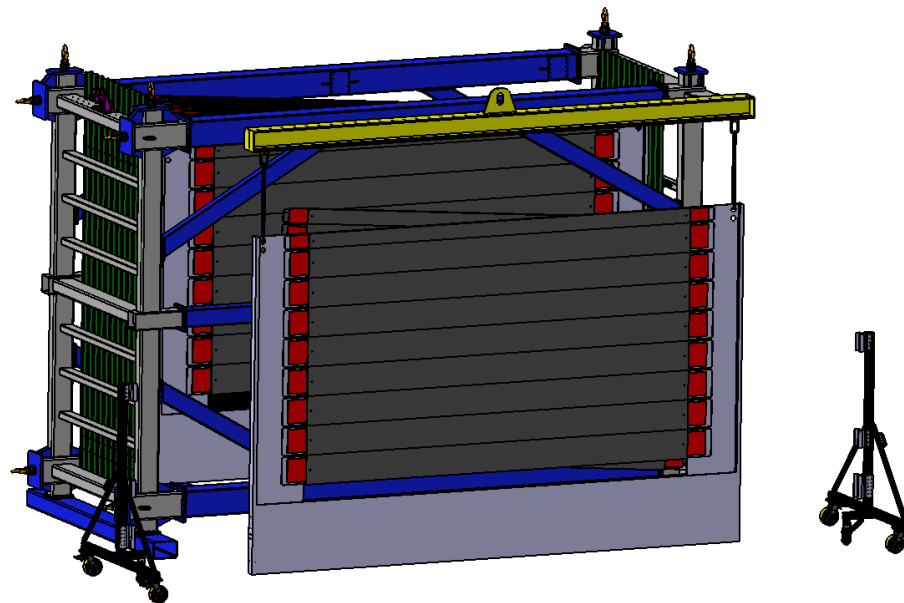

3. MUST transport from GSI to FAIR

6. The two trolleys are attached to the existing threaded holes of the C-frame.

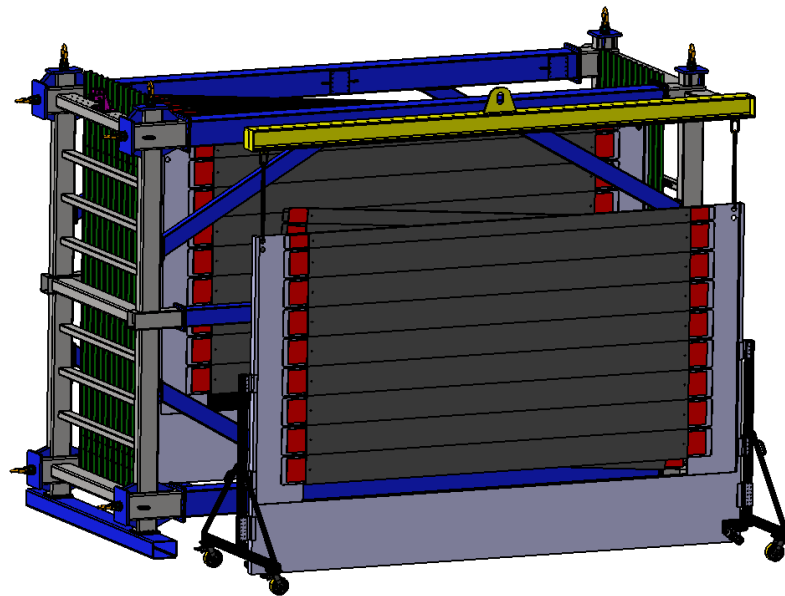

3. MUST transport from GSI to FAIR

7. When both trolleys are connected to the C-frame, the crane and transport frame can be removed.

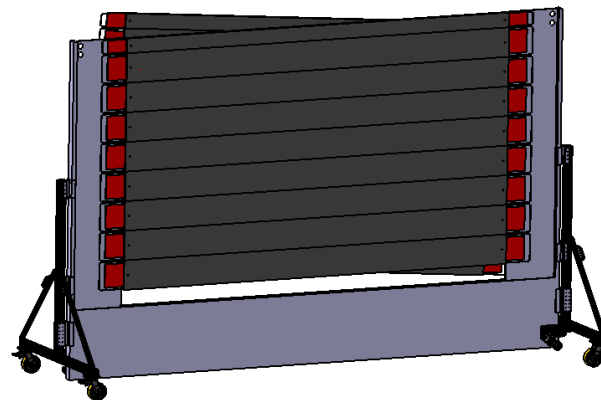

3. MUST transport from GSI to FAIR

- The trolley V1 consists mainly of profiles from ITEM. Additionally, various adapters for attaching the C-frame and roller for transport are included.

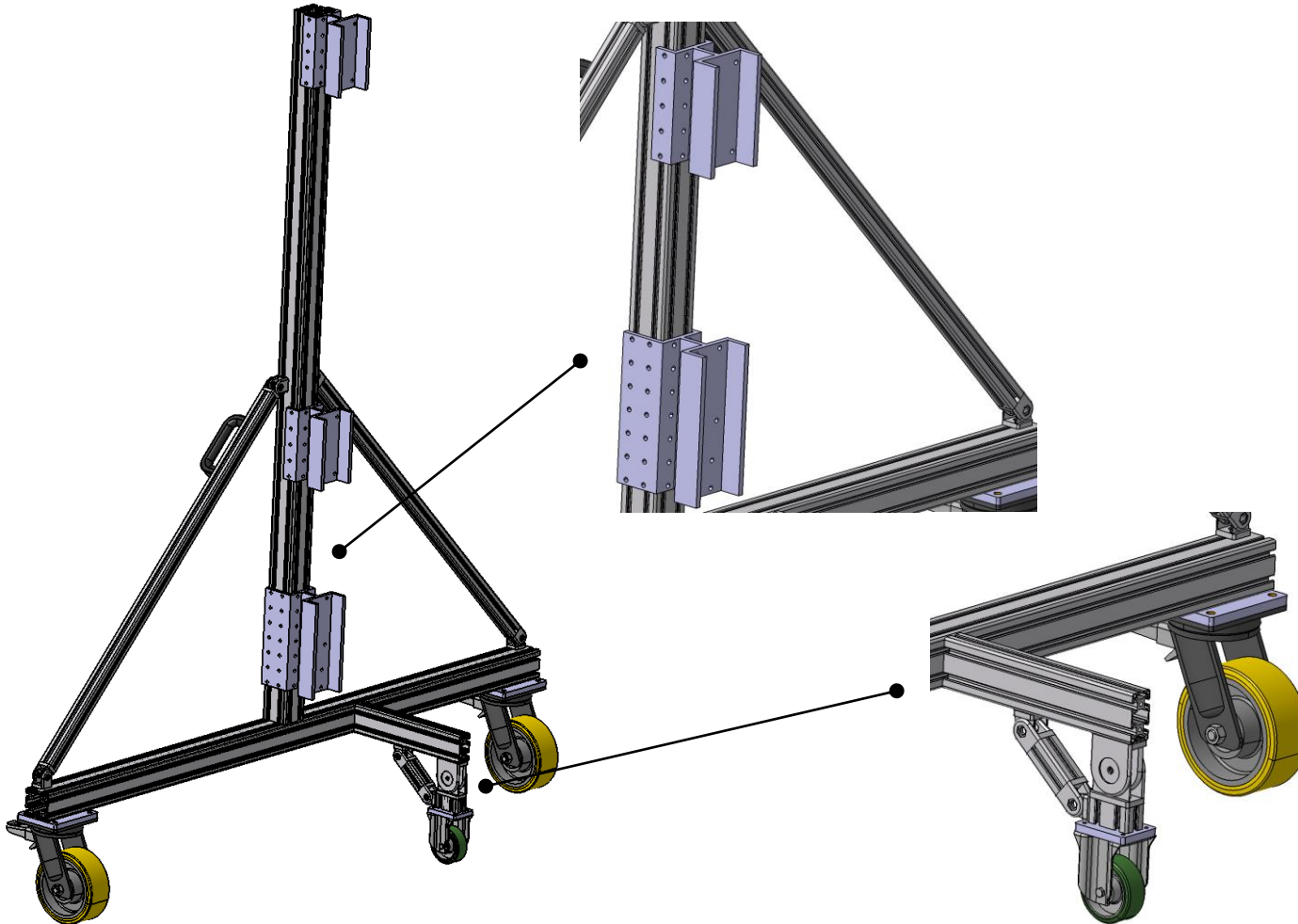

3. MUST transport from GSI to FAIR

- The small roller are used exclusively for the safe movement of the individual trolleys and can be folded away after being attached to the C-frame.

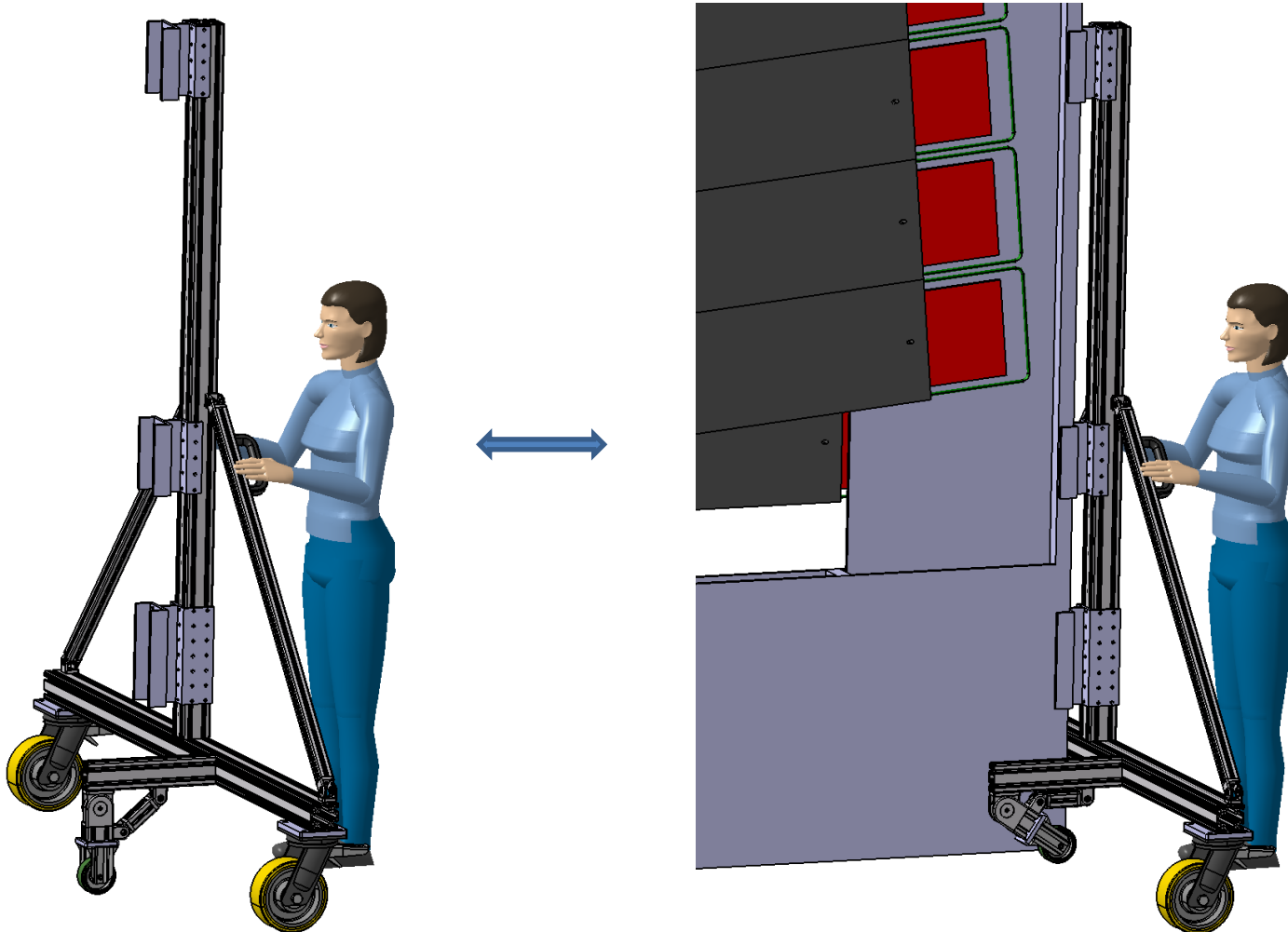

3. MUST transport from GSI to FAIR

- The position of the adapters, and thus the distance of the C-frame from the floor, can be adjusted as needed.
- The maximum height adjustment is 500 mm. However, this requires the C-frame to be decoupled from the trolley, as the adapters can only be moved without force.

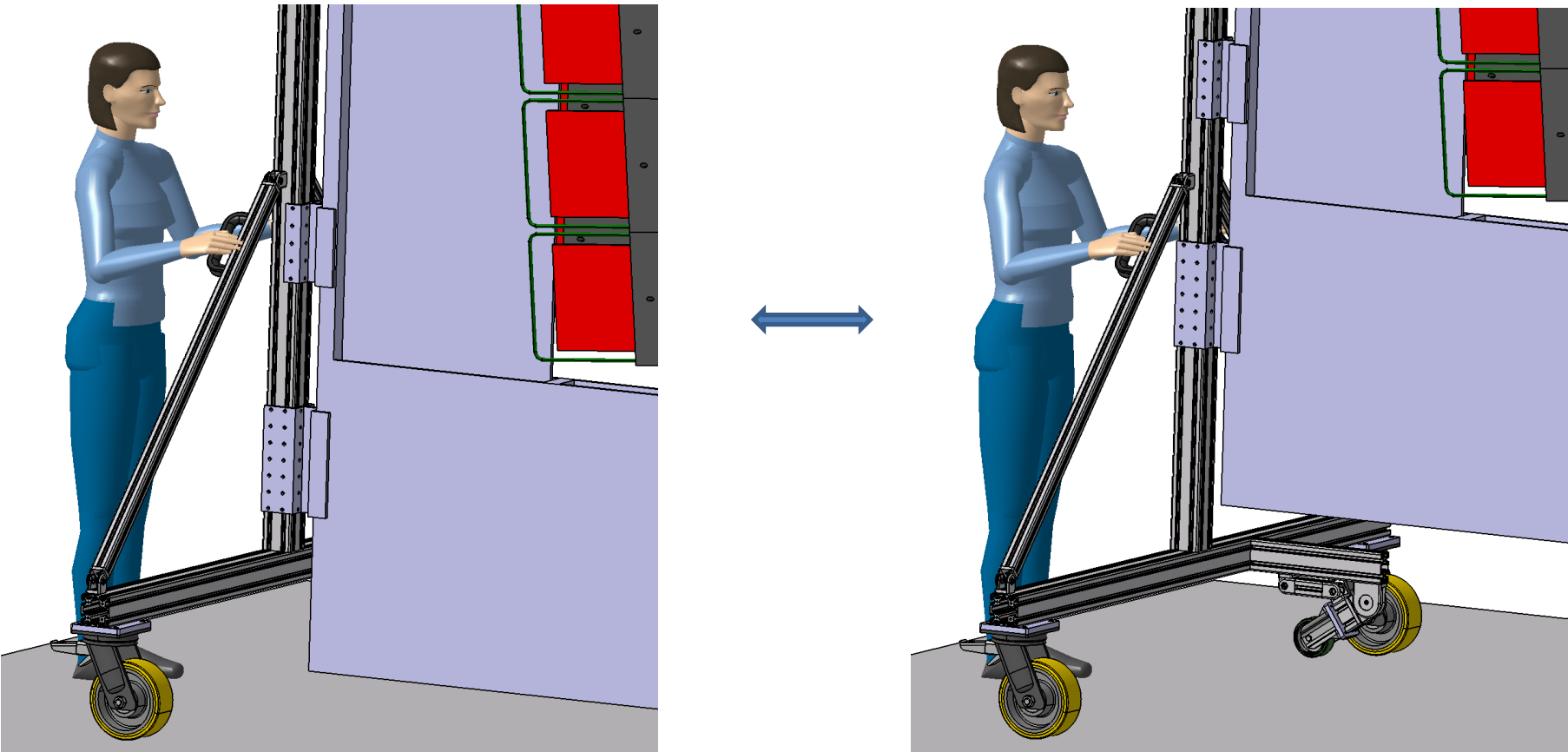

3. MUST transport from GSI to FAIR

- The trolleys are identical on both sides of the C-frame.

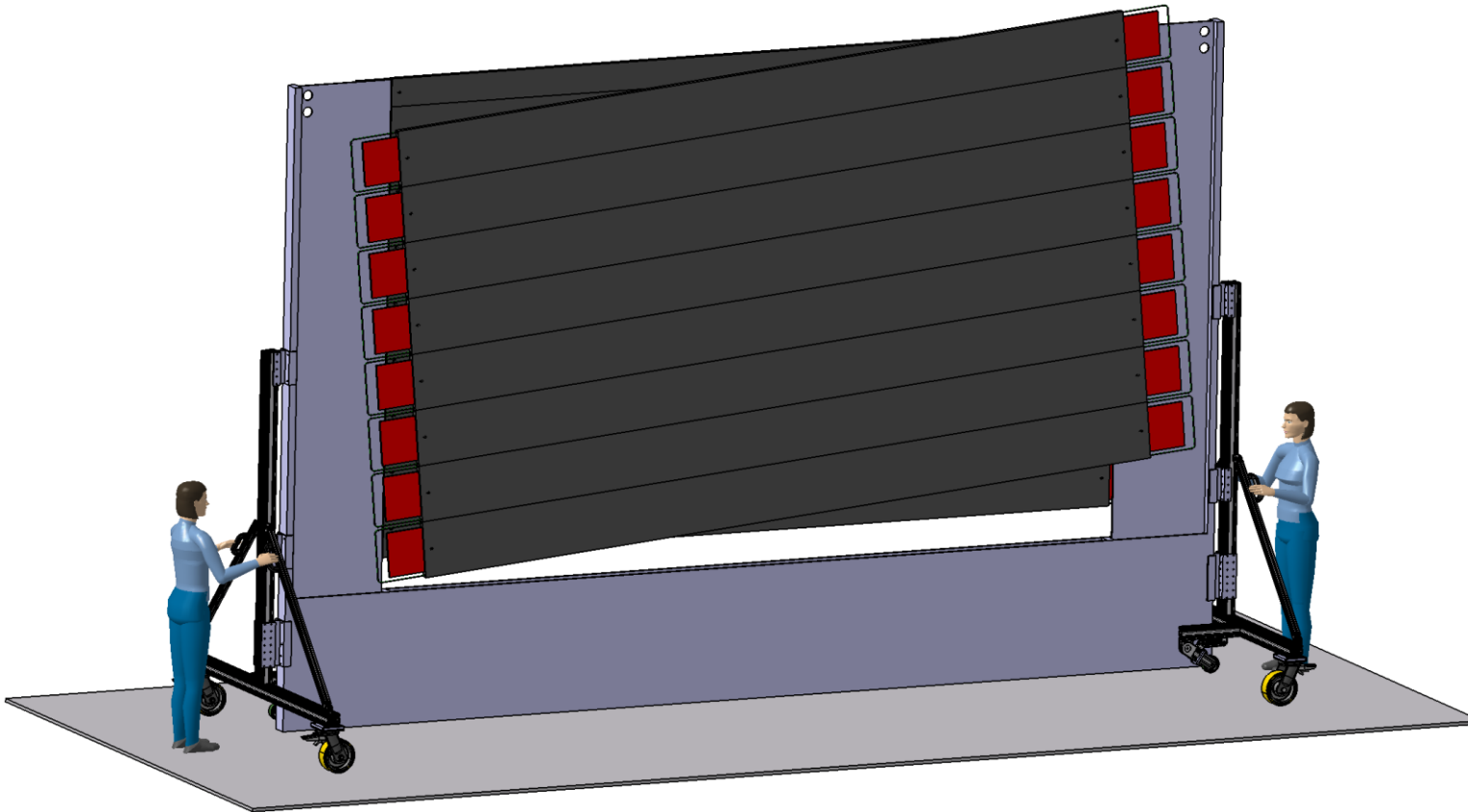

3. MUST transport from GSI to FAIR

c) Transport by MUST support frame

- The MUST mounting frame can be used as a transport frame in a horizontal position.

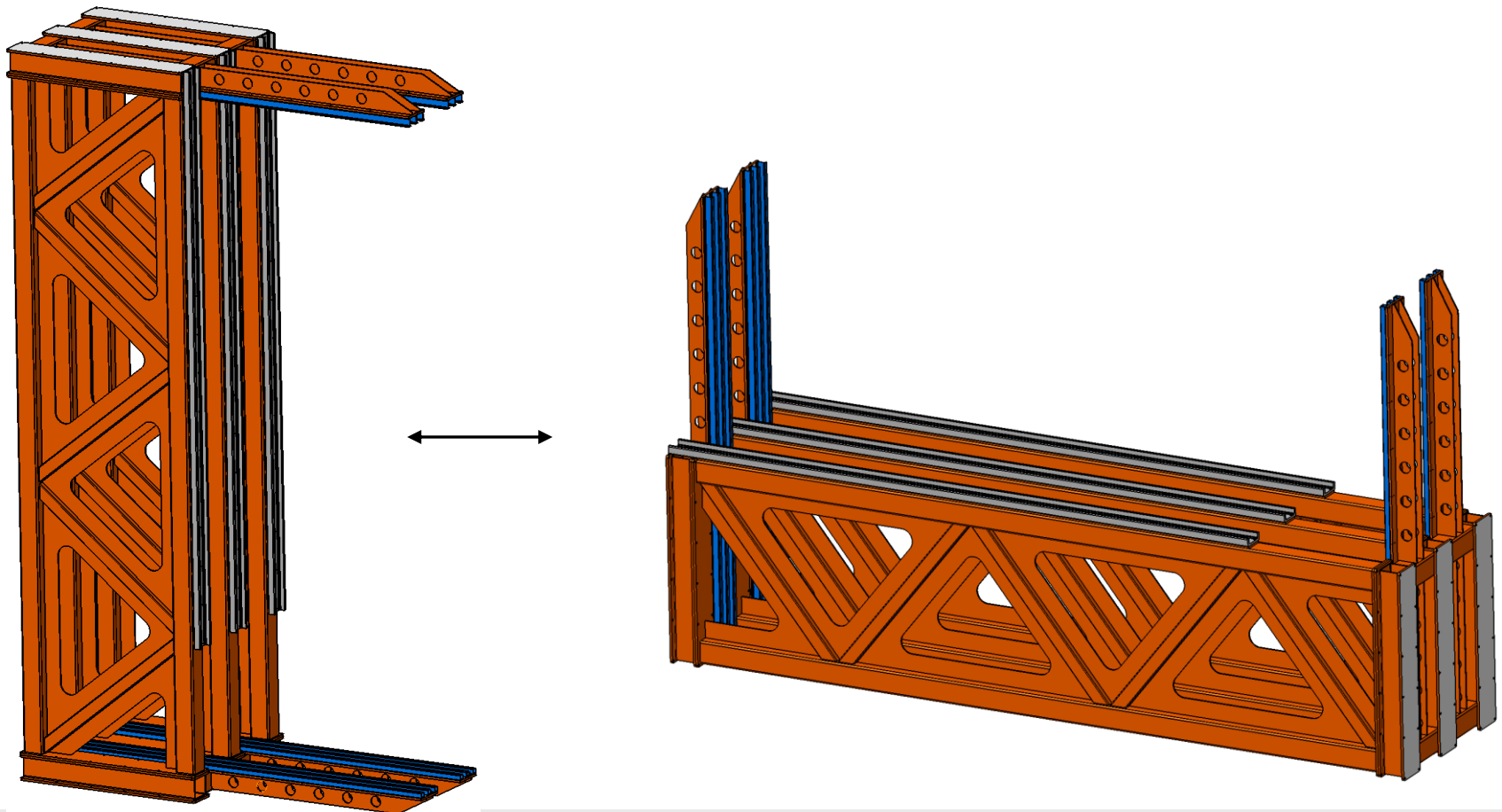

- This would mean that no additional transport devices are needed.

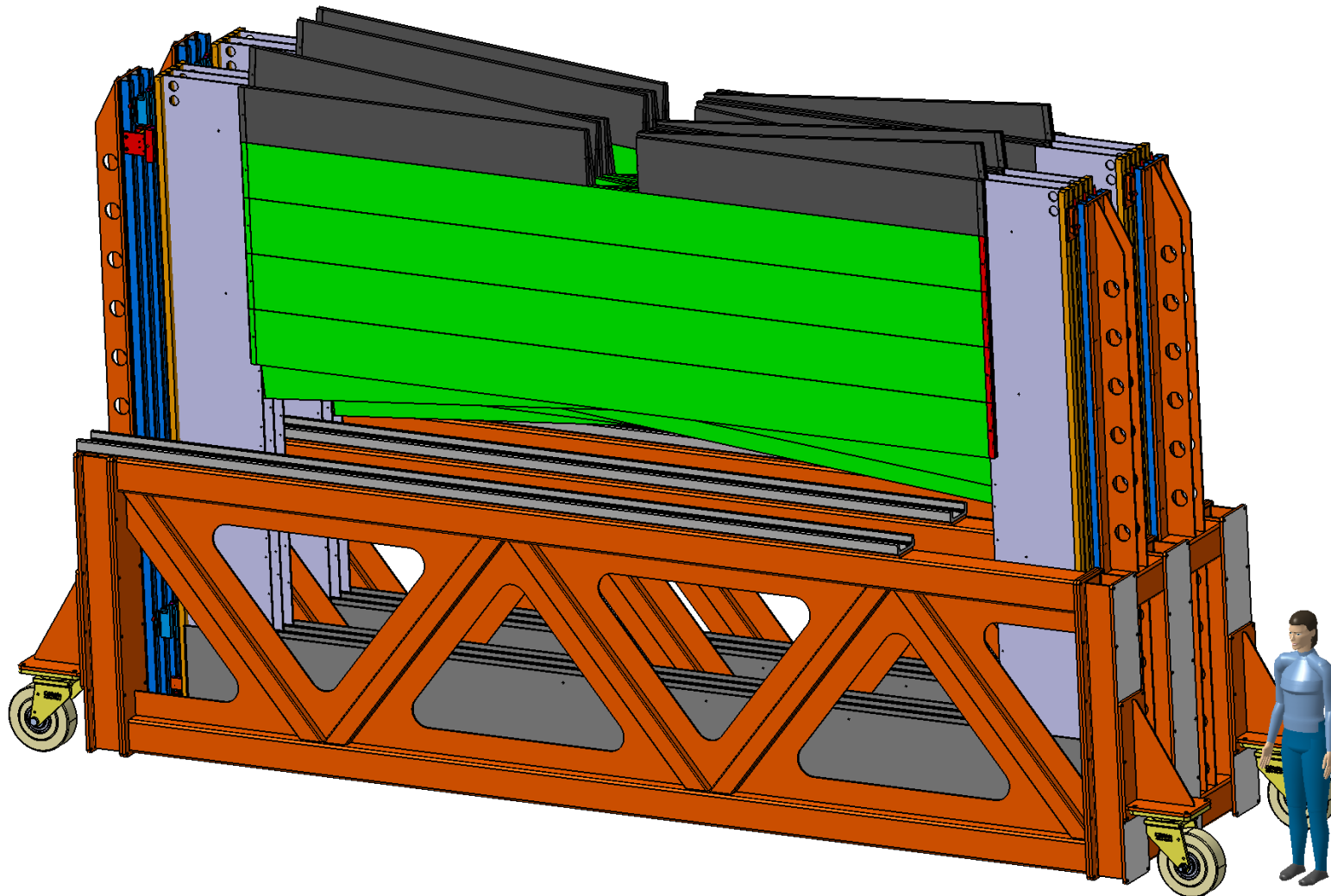

- Since the height of 4,5 meters is still quite high, the question is can we get this into CBM cave?

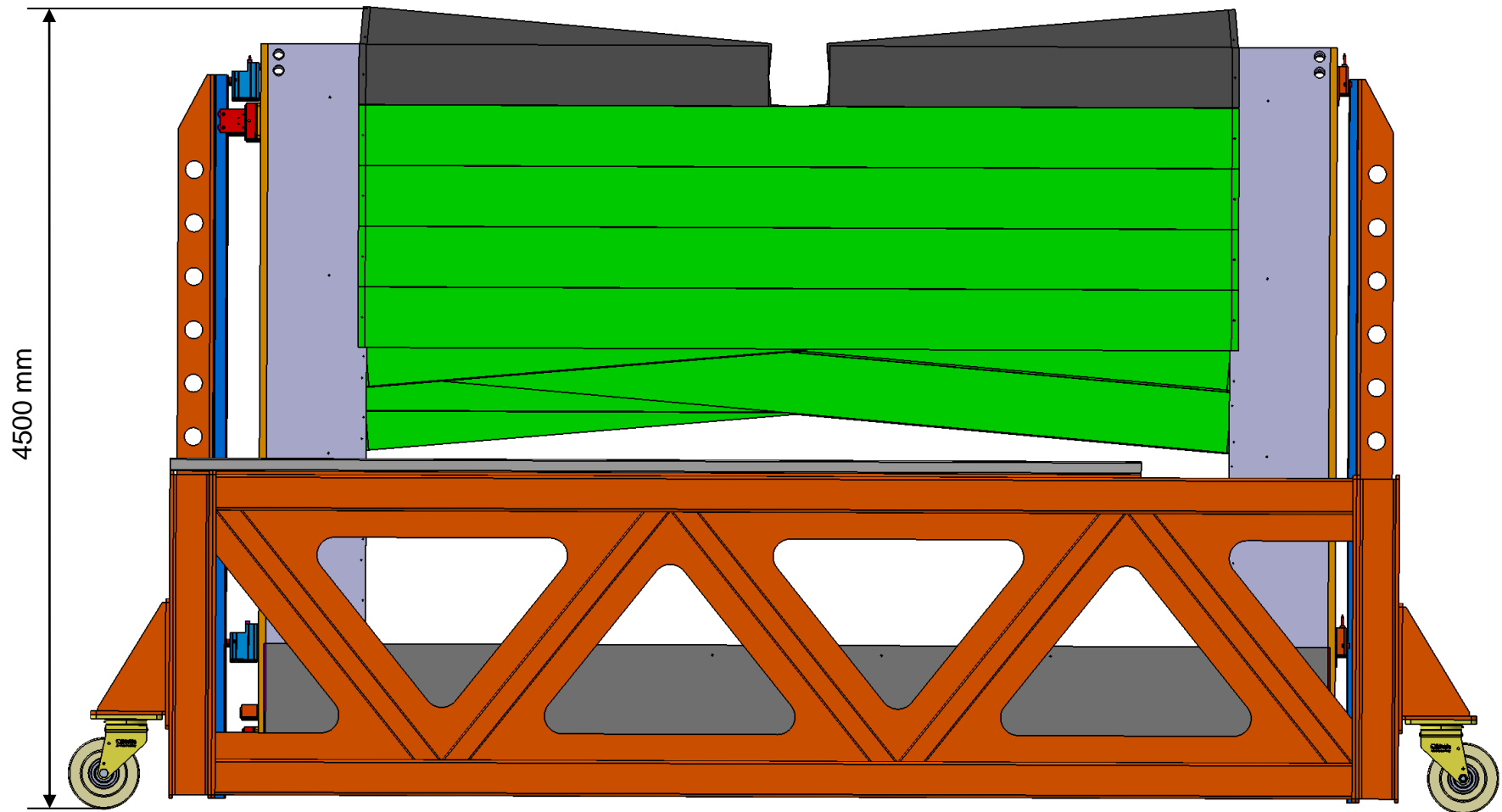

3. MUST transport from GSI to FAIR



d) ...

- The transport options we have presented are not the final design.
- Other ideas and proposals are welcome and can be discussed further.

4. Advanced design of MUST support frame including absorber 5

- By extending the initial design of the MUST support frame, it can also secure the absorber 5.

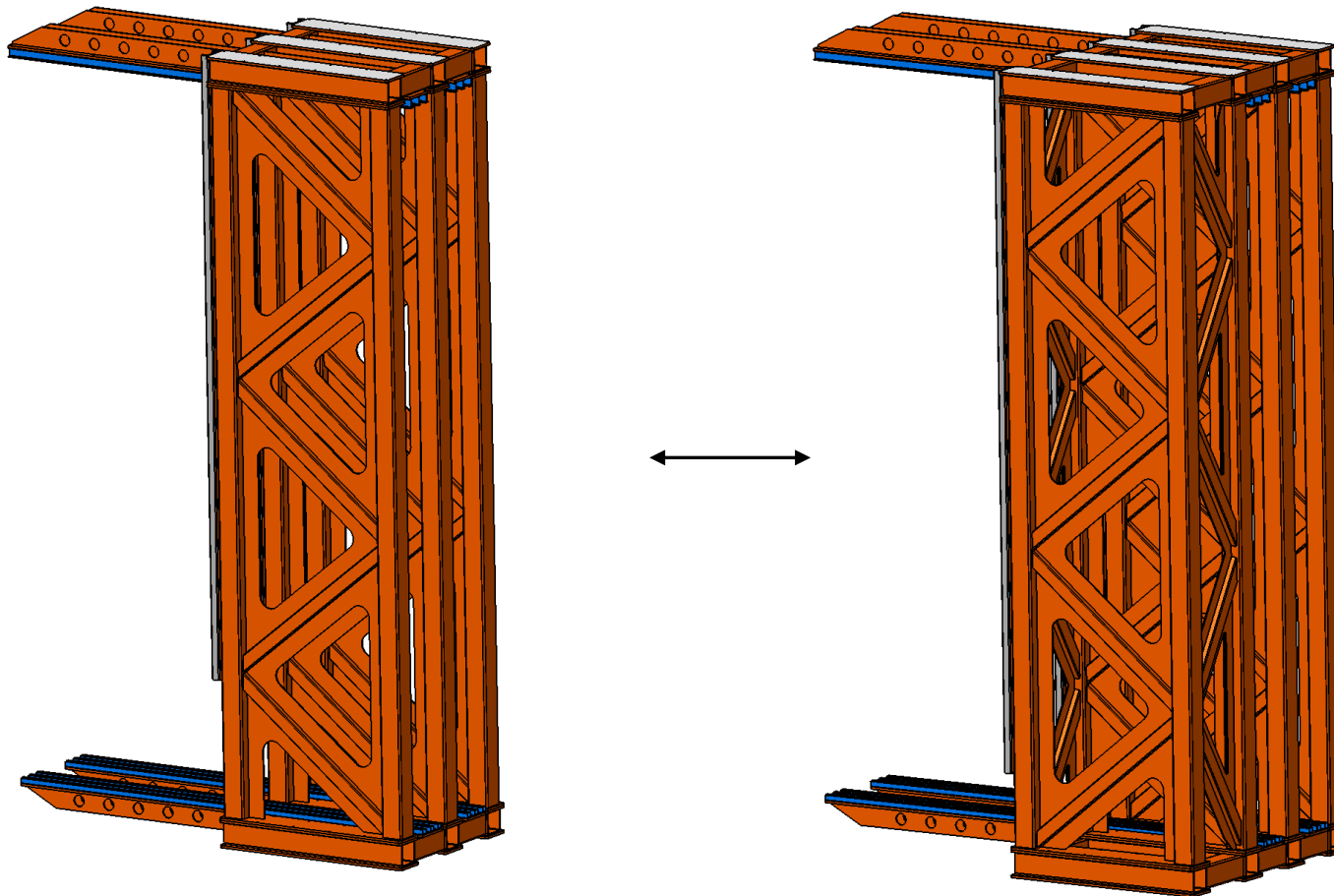

4. Advanced design of MUST support frame including absorber 5

- This could eliminate the need for an additional horizontal support structure for absorber 5.

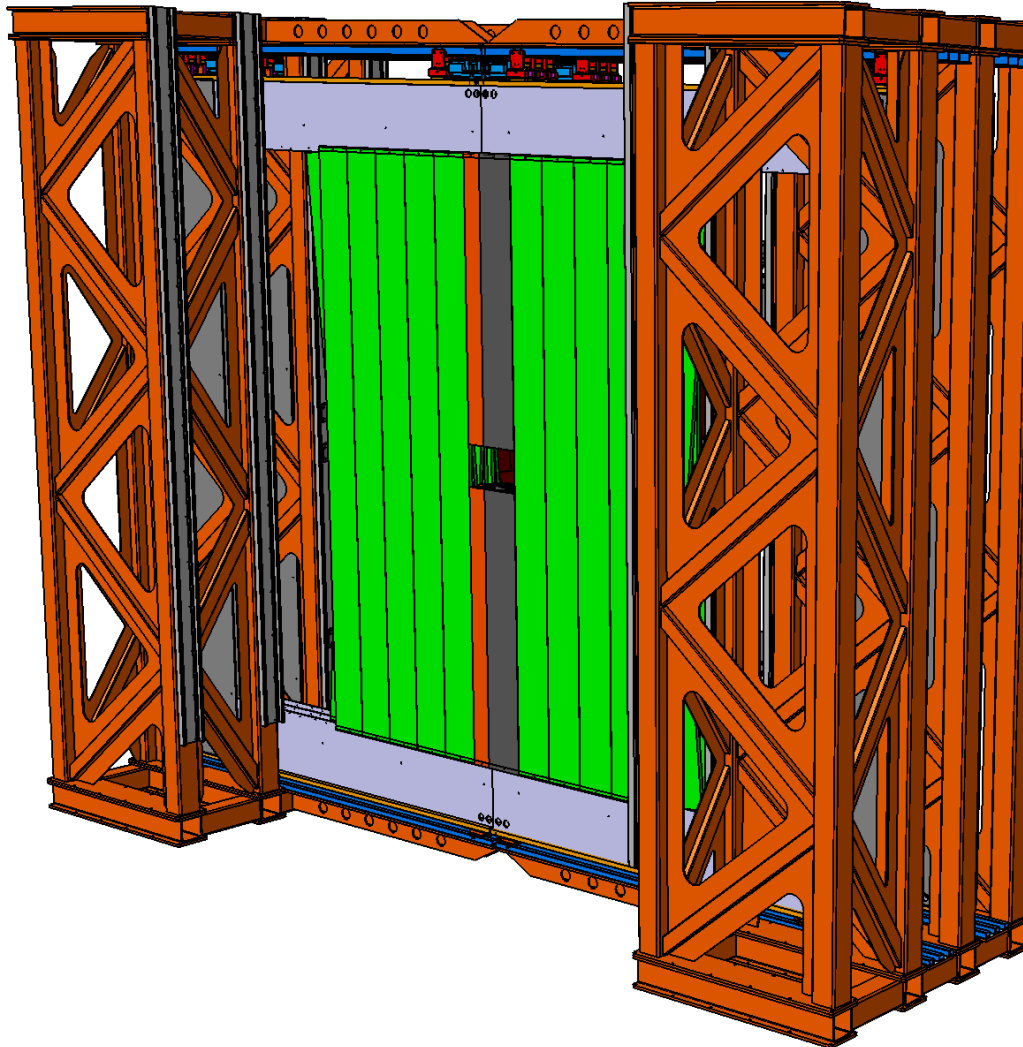

4. Advanced design of MUST support frame including absorber 5

- This could eliminate the need for an additional horizontal support structure for absorber 5.

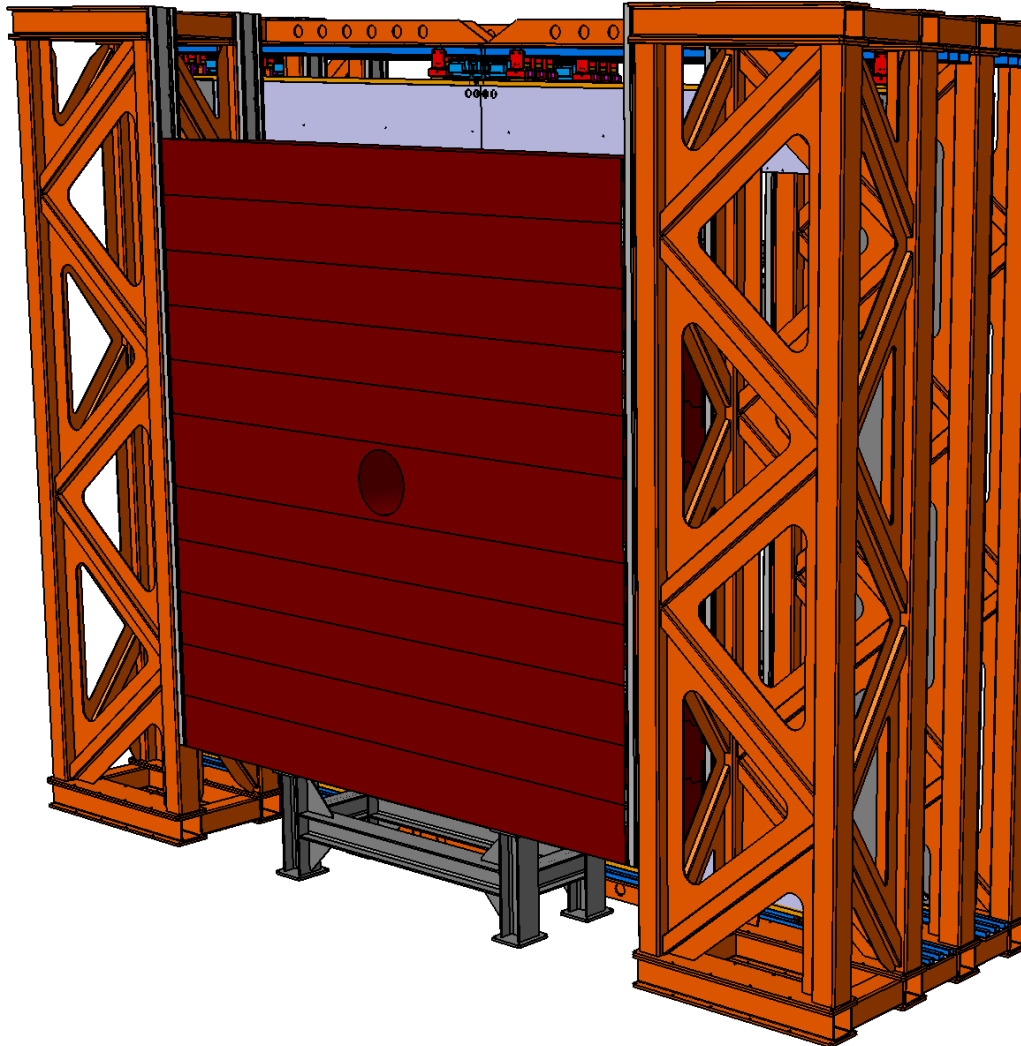

4. Advanced design of MUST support frame including absorber 5

- Finally, here is an image showing what the setup in CBM would look like. The first picture shows the RICH setup, and the other the setup with MUST.

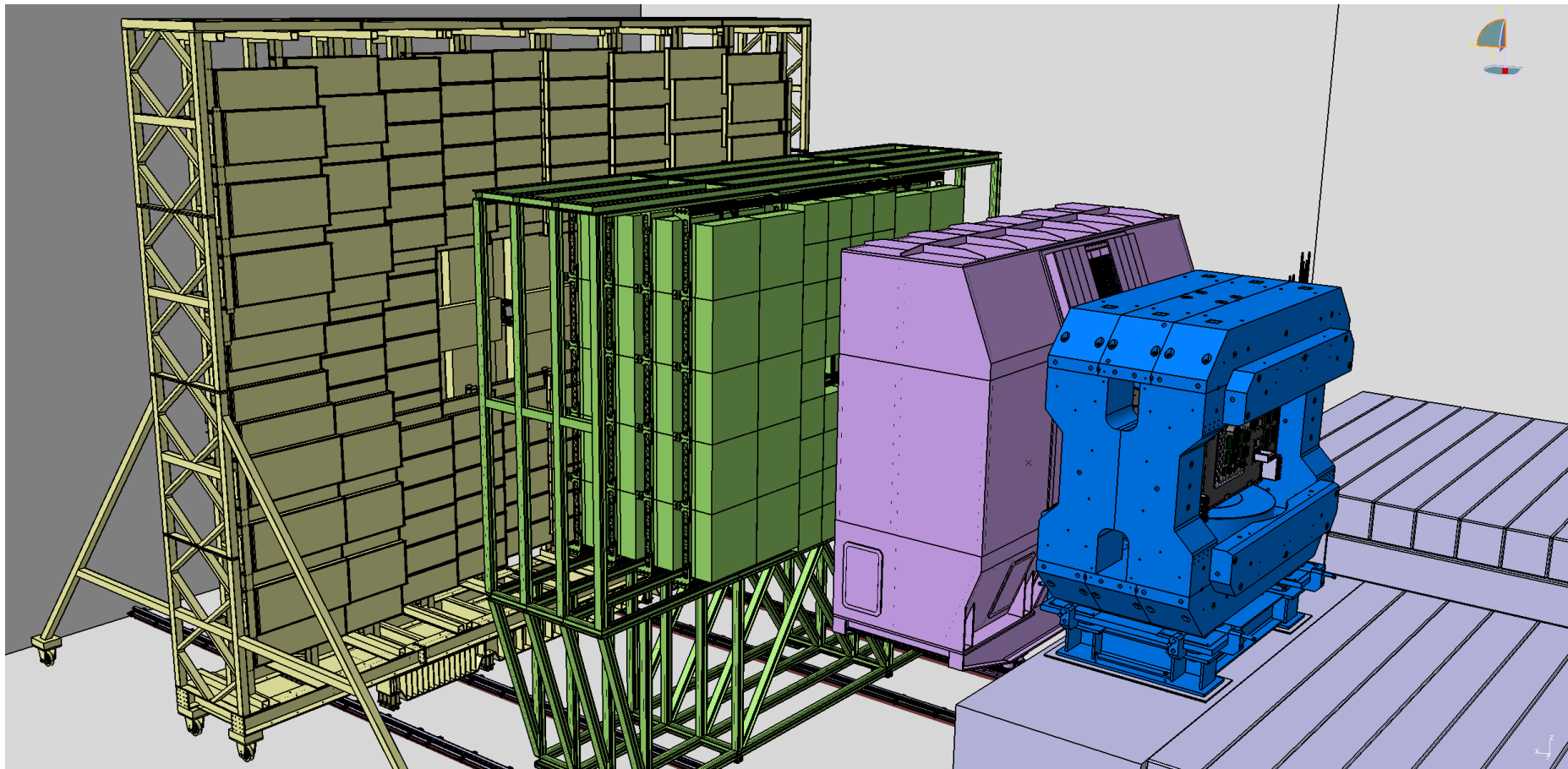

4. Advanced design of MUST support frame including absorber 5

- Finally, here is an image showing what the setup in CBM would look like. The first picture shows the RICH setup, and the other the setup with MUST.

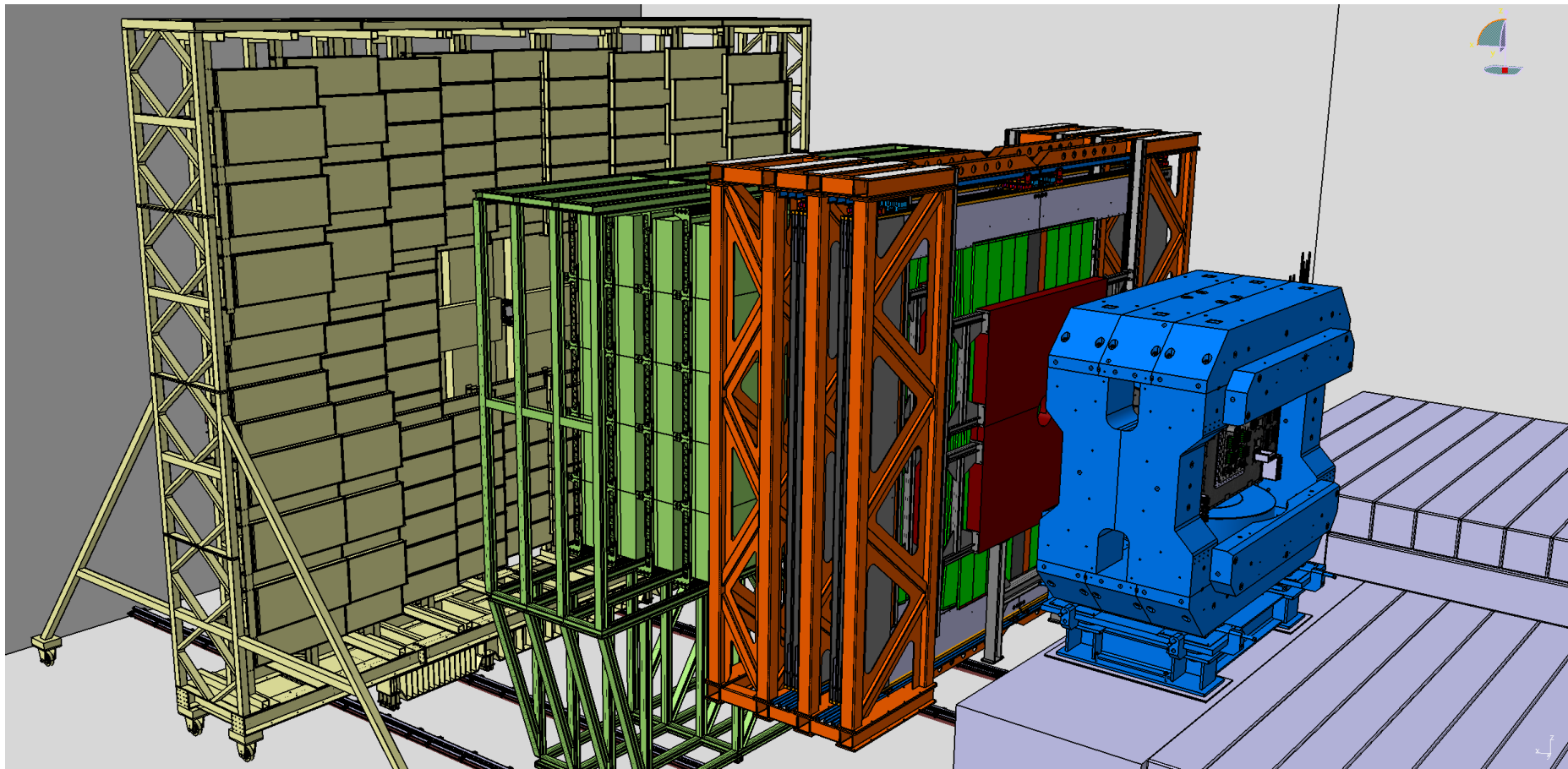

5. Open items and next steps

- Review of the concepts regarding potential conflicts with other CBM components.
- Review the absorber layout for MUST.
- First calculation and structural verification of the concept.
- Integration of services and their components, such as electrical, gas, readout etc., into the concept.
- Check how the detector can be transported to CBM.

Thank you for your attention!