

Sympathetic laser-cooling of a single heavy ion in a Penning trap

Manuel Almagro Cabeza
Departamento de Física Atómica Molecular y Nuclear
Laboratorio de trampas de Iones y Láseres
Universidad de Granada
manuelalmagro@ugr.es
<http://trapsensor.ugr.es>

TASCA Workshop 2026

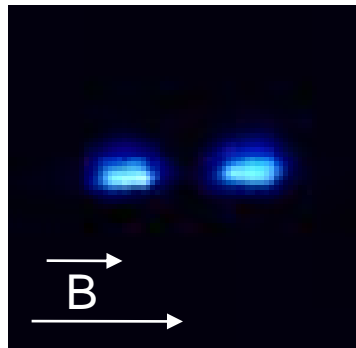

19th – 21st May 2026

Outline

- Motivation
- Photon-based detection method
- Experimental setup
- Results
- Summary and outlook

Motivation

Destructive techniques

- ToF-ICR
- PI-ICR

Non-destructive techniques

- PnP Technique

Main limitation

- Low production rate

O. Kaleja et al, PRC 106, 054325 (2022)

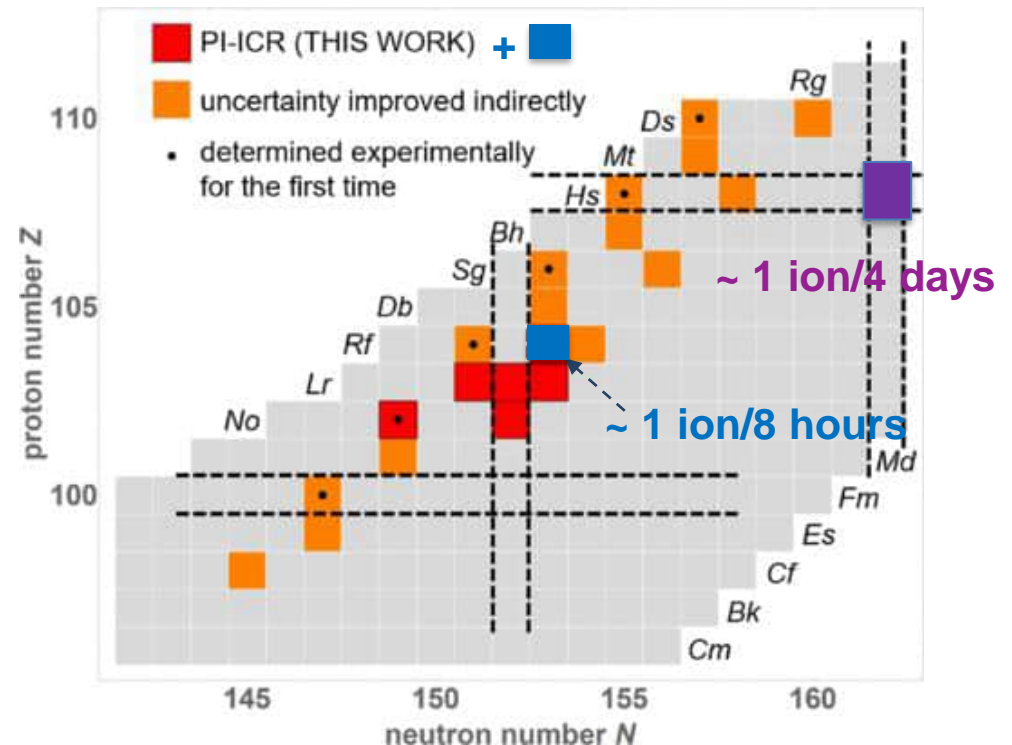

Our approach → Photon based detection

Possible application on laser-spectroscopy experiments ?

Photon-based detection method



UNIVERSIDAD
DE GRANADA



Laboratorios
Singulares
UGR

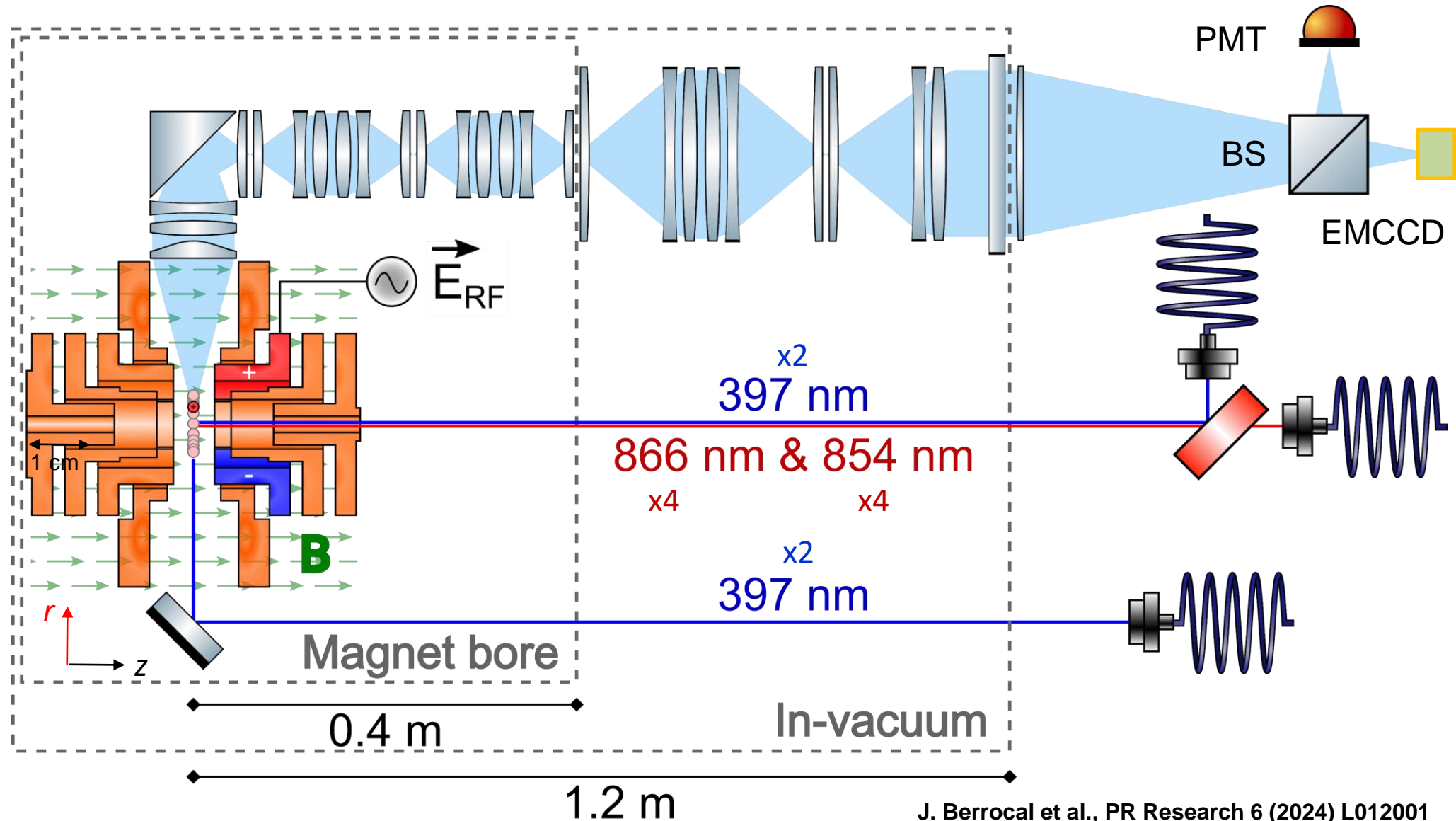

Photon-based detection method

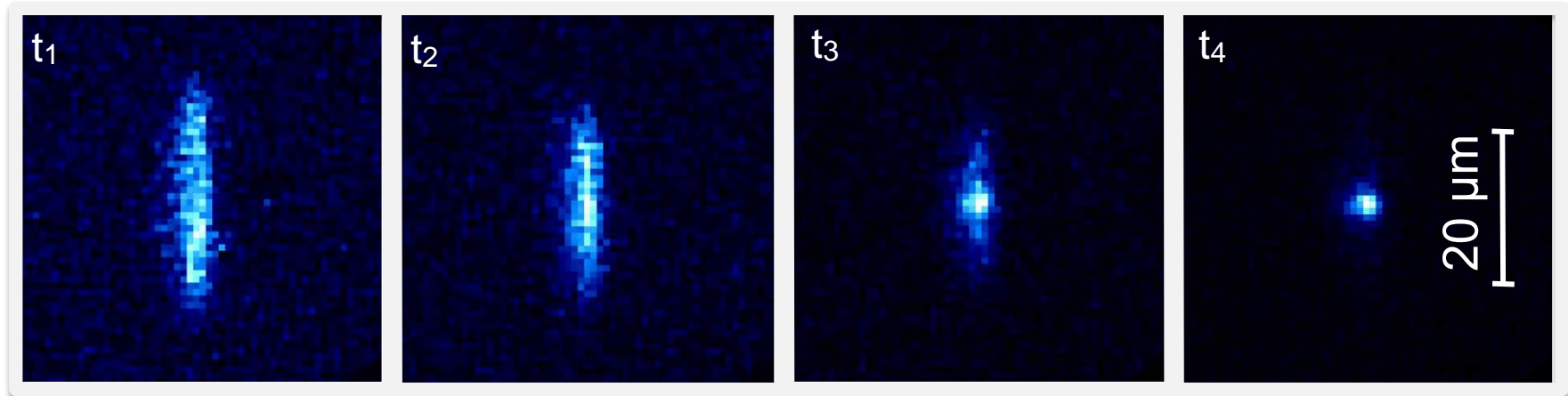

Main advantages

- Universal
- High sensitivity in position and energy

Main challenge

- Sympathetic cooling
- Effect of Coulomb interaction in identification

Protocol: with/without lasers

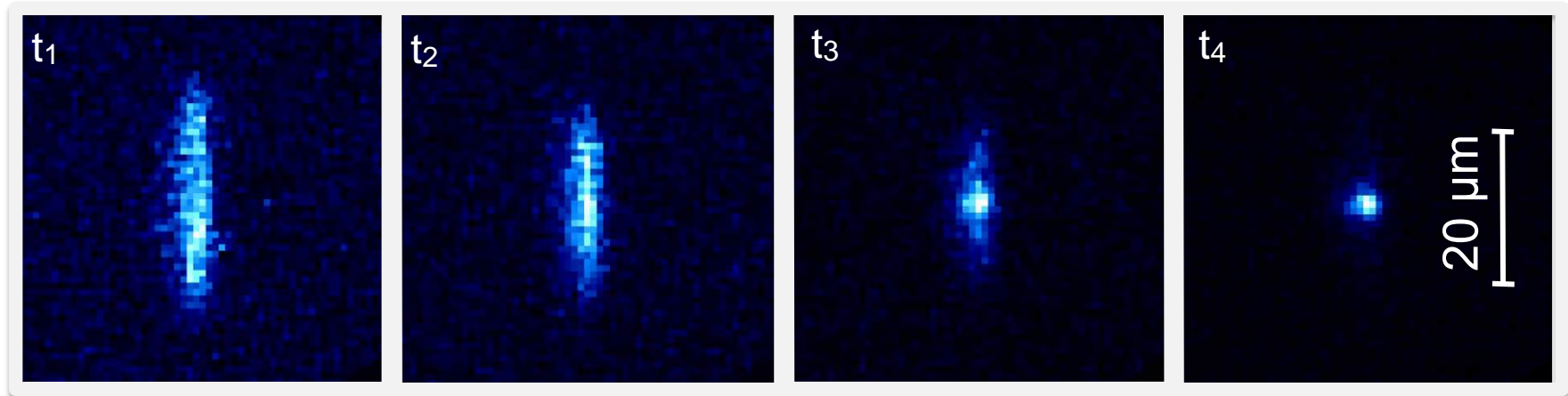

Approach 1

- Scan RF excitation close to resonance
- Laser cooling off while excitation
- Turn on laser cooling for readout

Better precise but longer measurement times (minutes)

Approach 2

- RF excitation close to resonance
- Lasers on while excitation and simultaneous readout

Good resolving power and short measurement time (seconds)

Protocol: with/without lasers

Magnetron

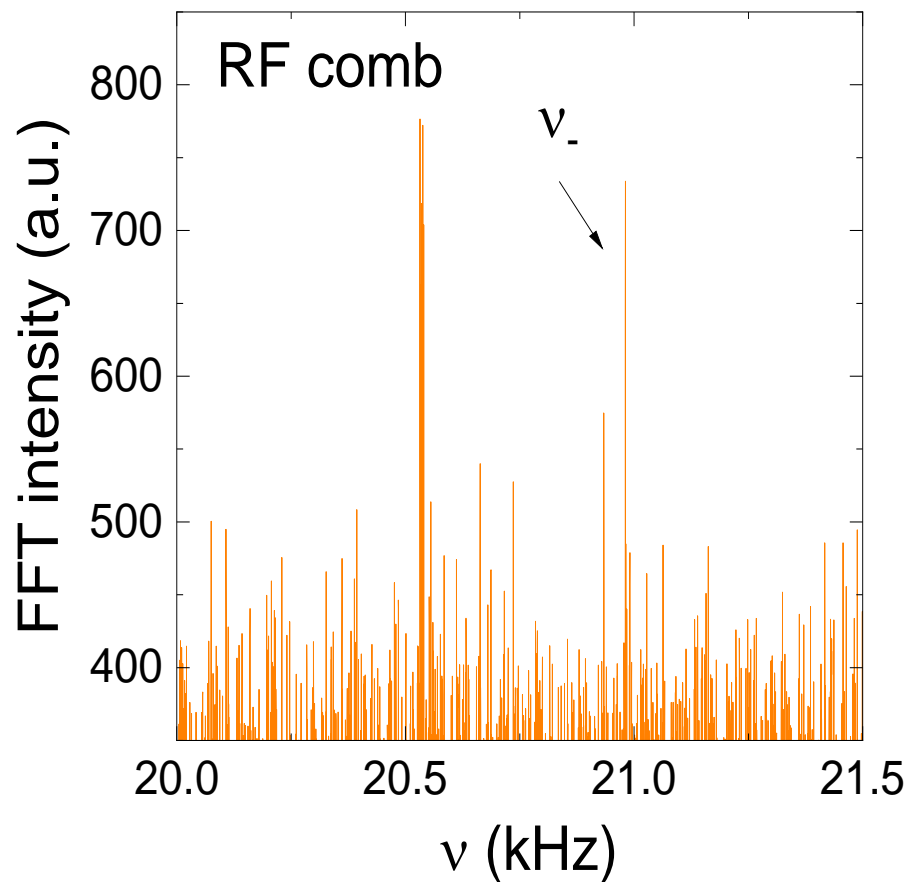

Reduced-Cyclotron

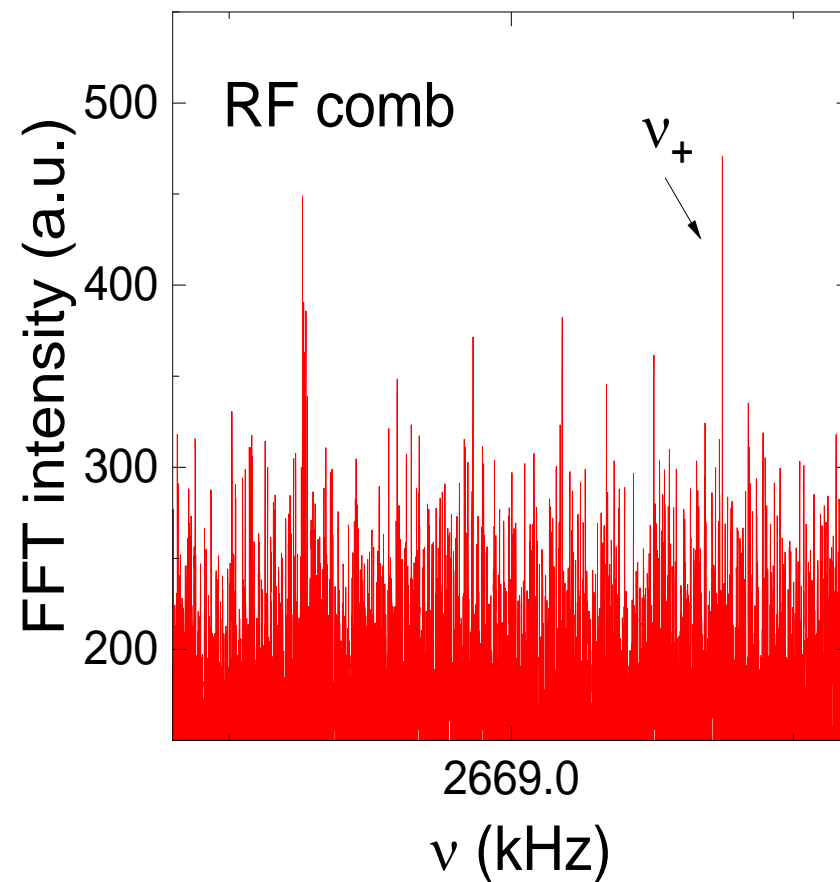

Old Penning trap setup

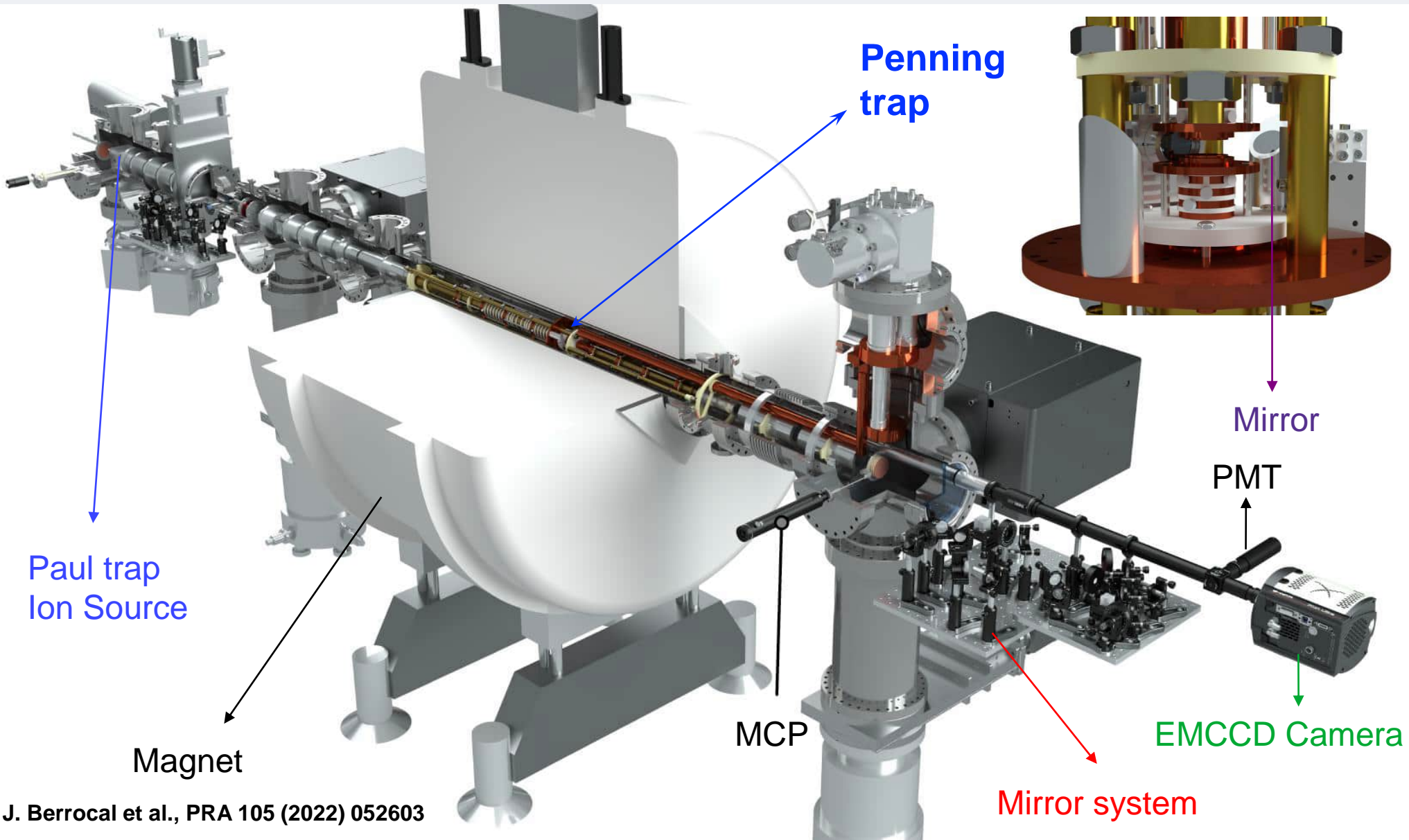

New cryogen-free magnet



UNIVERSIDAD
DE GRANADA

Laboratorios
Singulares
UGR

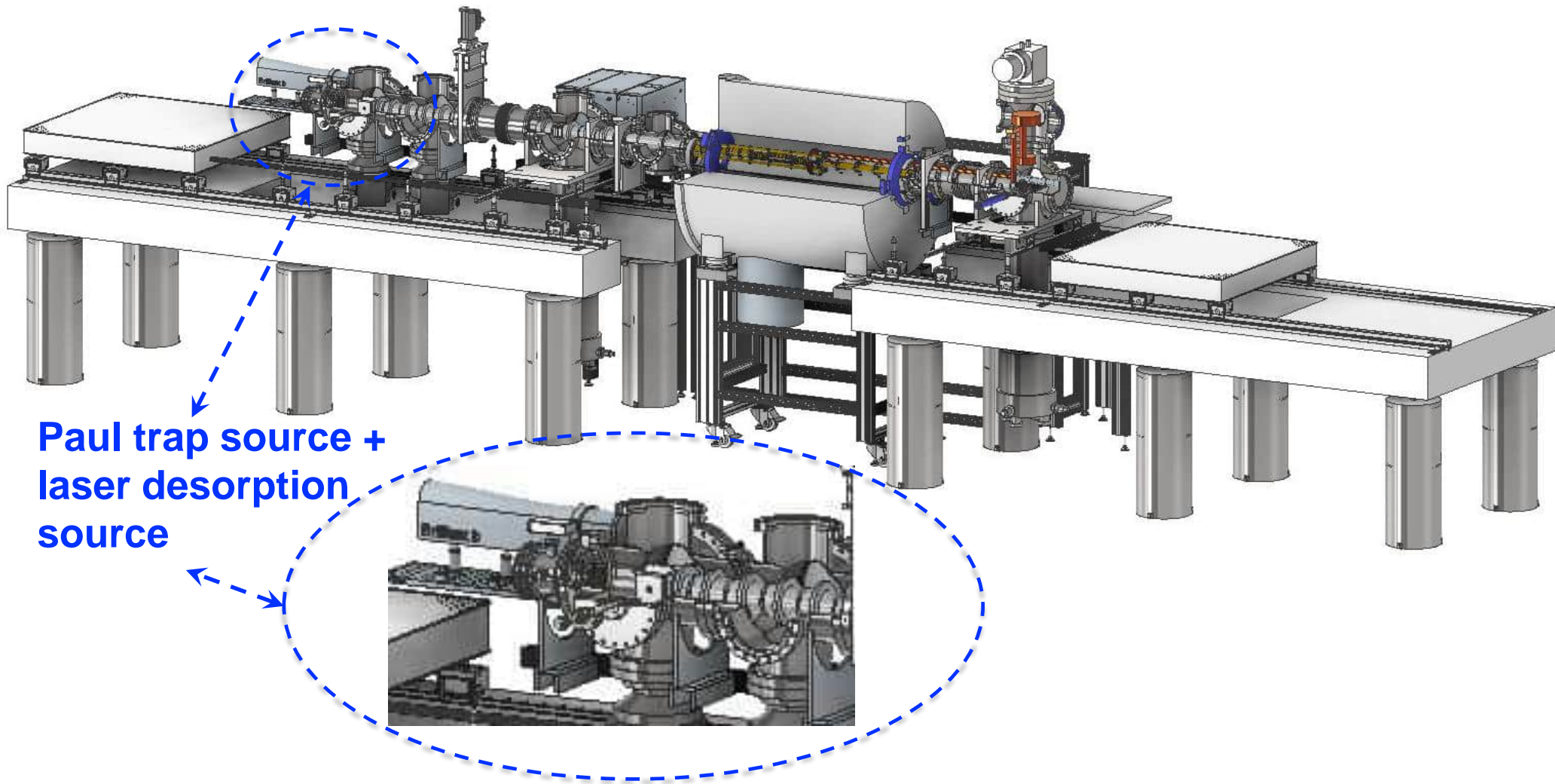

Paul trap source +
laser desorption
source

Two-ion hybrid crystals in a cryogen-free magnet



UNIVERSIDAD
DE GRANADA

Laboratorios
Singulares
UGR

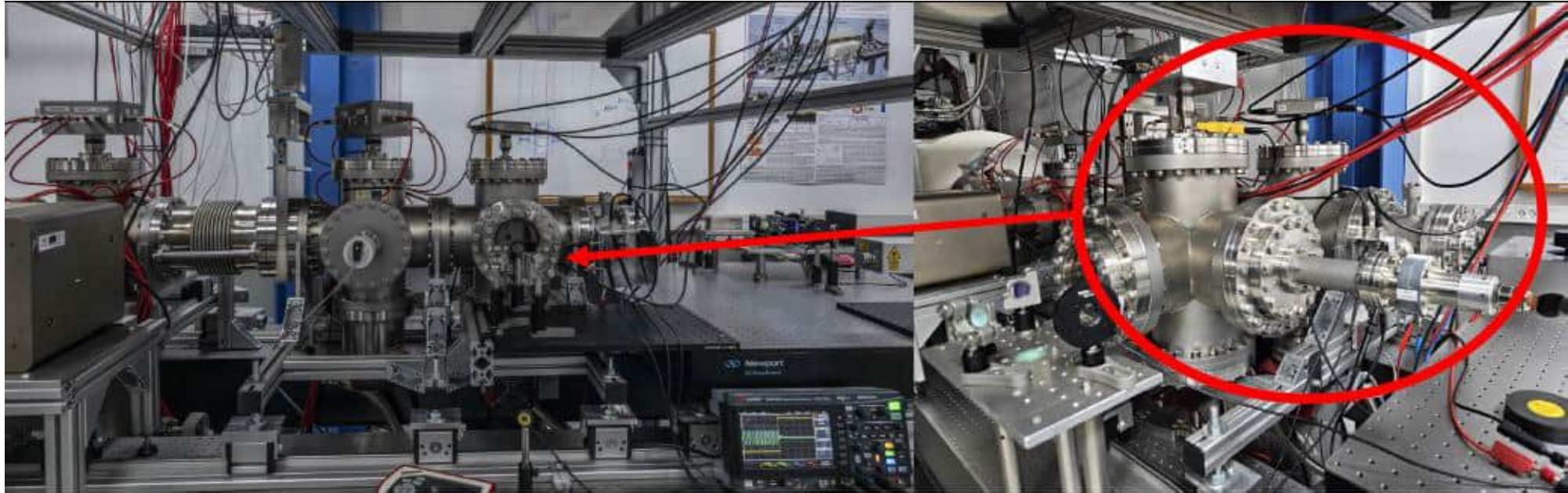

- **Source characterization and energy spread measurements**
 - + laser desorption source
 - + electron gun + MCP detector

Source characterization

Production energy

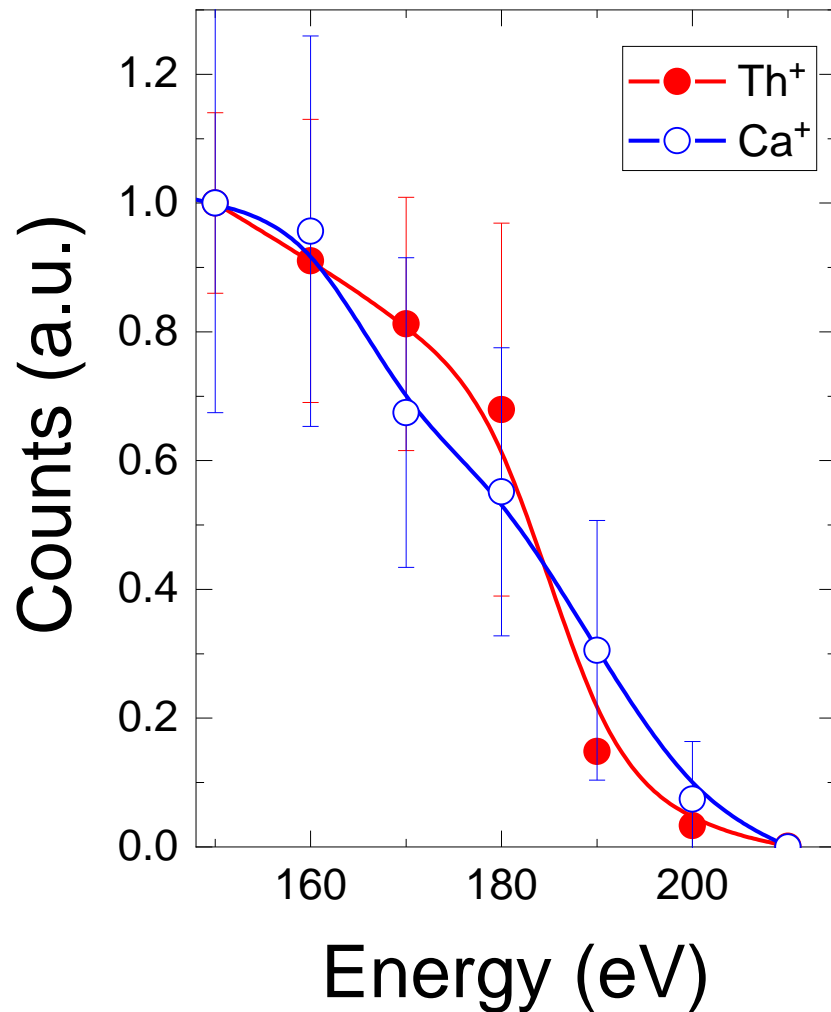

Species	Energy (eV)
Ca (photoionization)	188.89 ± 8.25
Th (laser ablation)	176.48 ± 2.76

Doppler cooling in a 7-T Penning trap

- **Transitions & lasers**

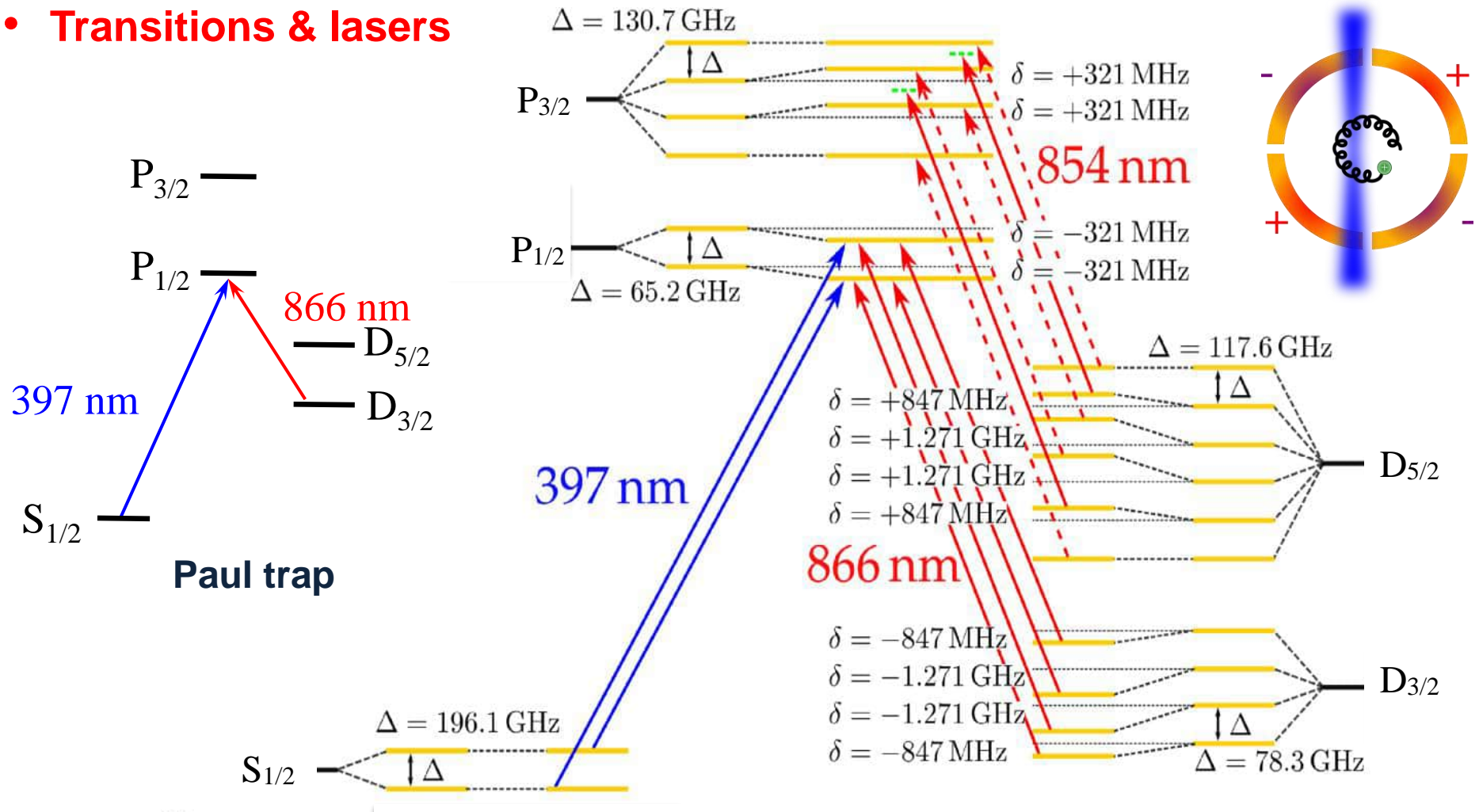

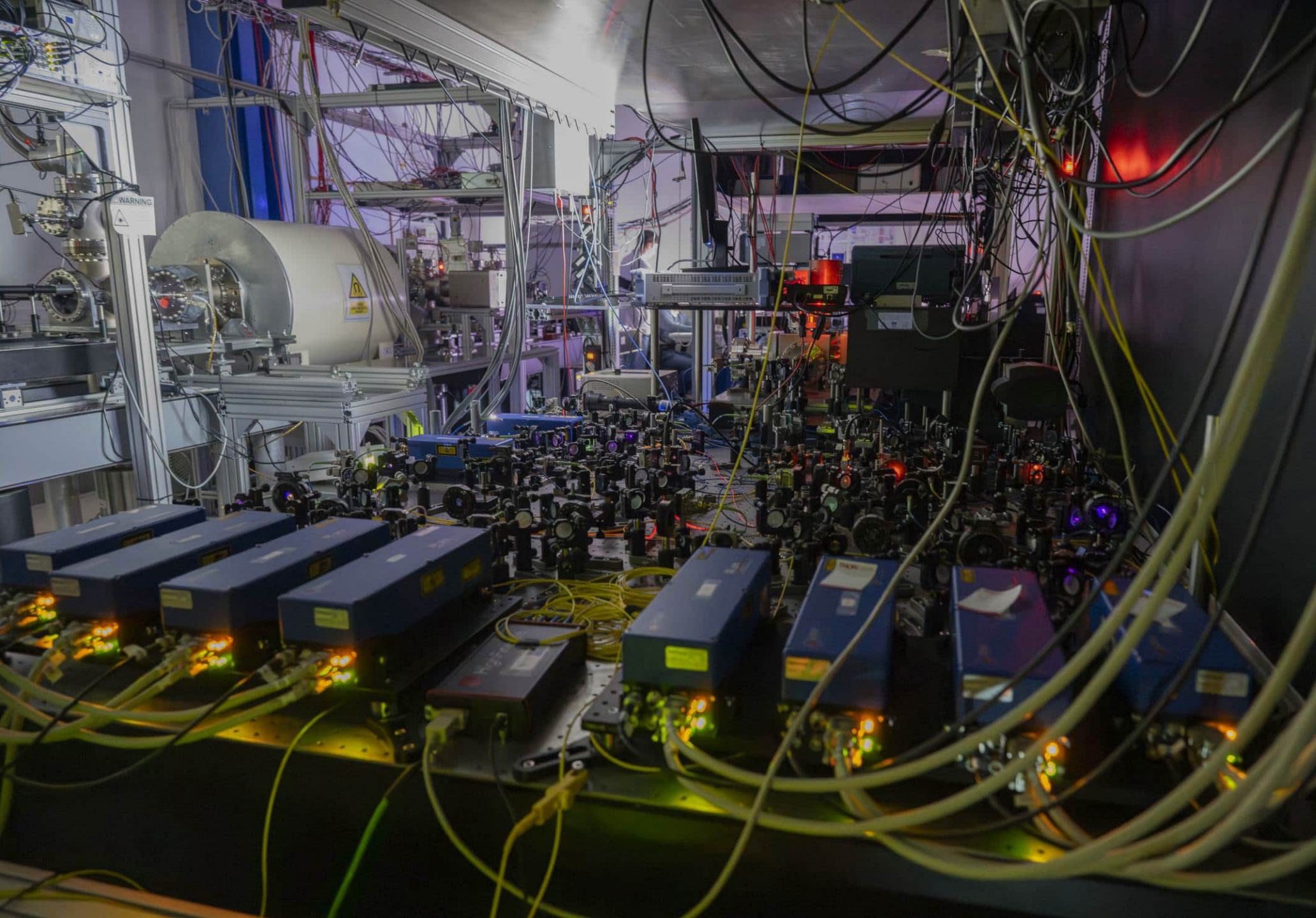

WARNING



Formation of a hybrid crystal

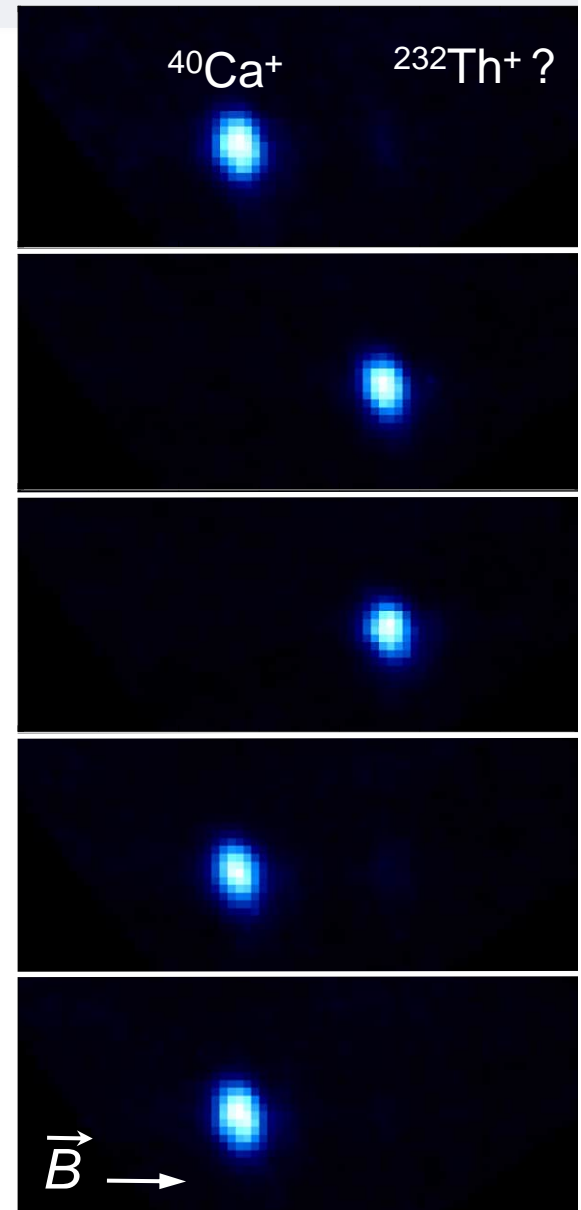
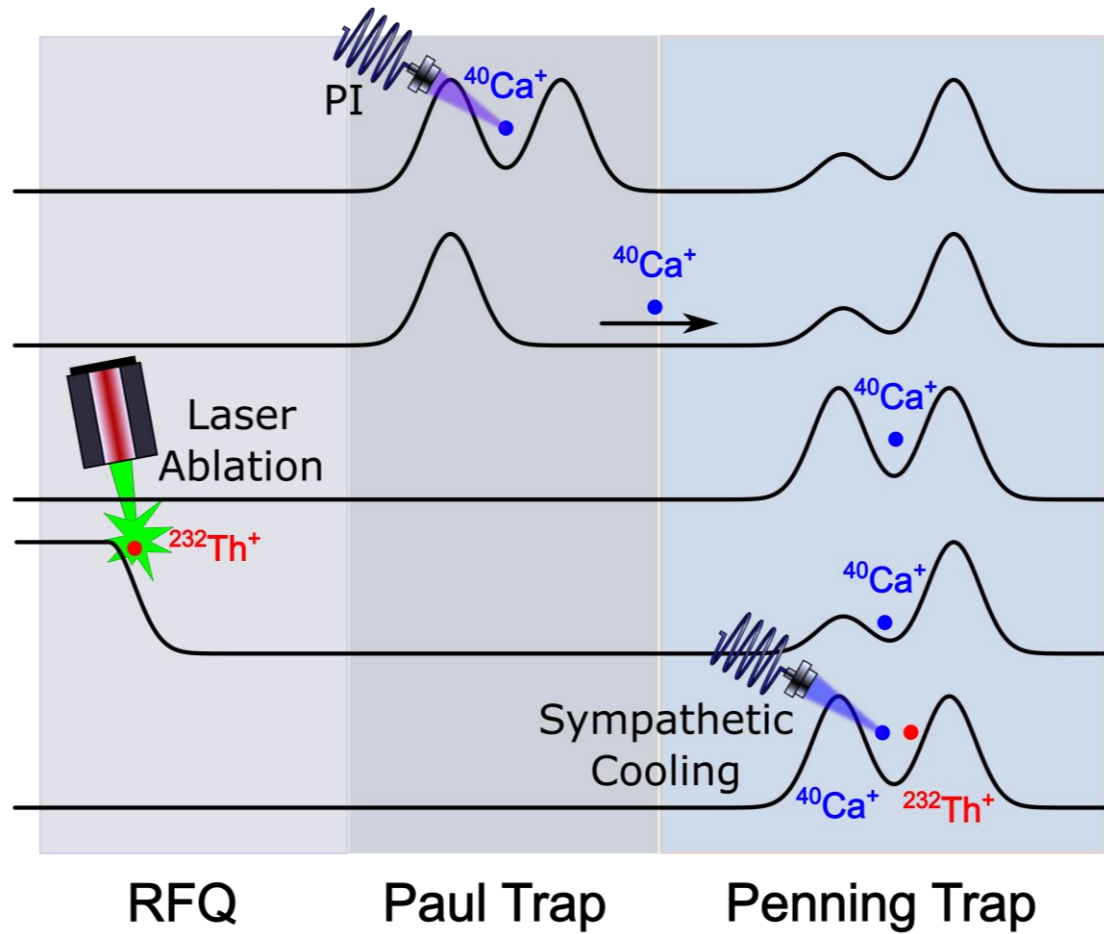

Time for direct laser cooling

Static Doppler cooling

Trap Depth (V)	Cooling time (s)
30	320 ± 210
20	310 ± 210
10	206 ± 100

Efficiency > 70 %

Dynamic Doppler cooling

Trap Depth (V)	Cooling time (s)
30	140 ± 50
20	60 ± 40
10	60 ± 40

Efficiency ~ 30 %

Identification of the trapped ion



UNIVERSIDAD
DE GRANADA



Laboratorios
Singulares
UGR

- **Five trap depths (resolution 0.02 V)**

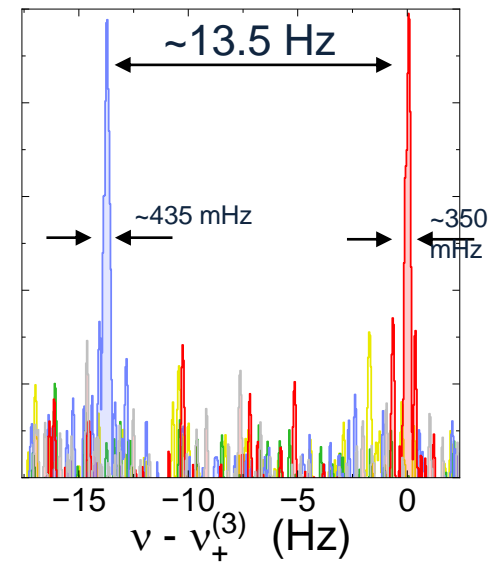
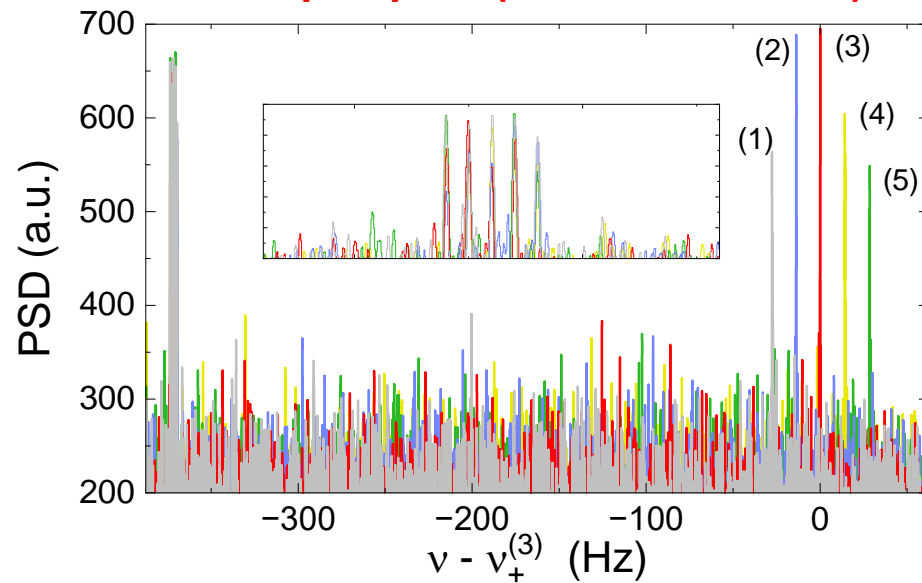

Publication in progress

Identification of the trapped ion

Cyclotron frequency determination

- Measurements performed with a $^{44}\text{Ca}^+$ ion

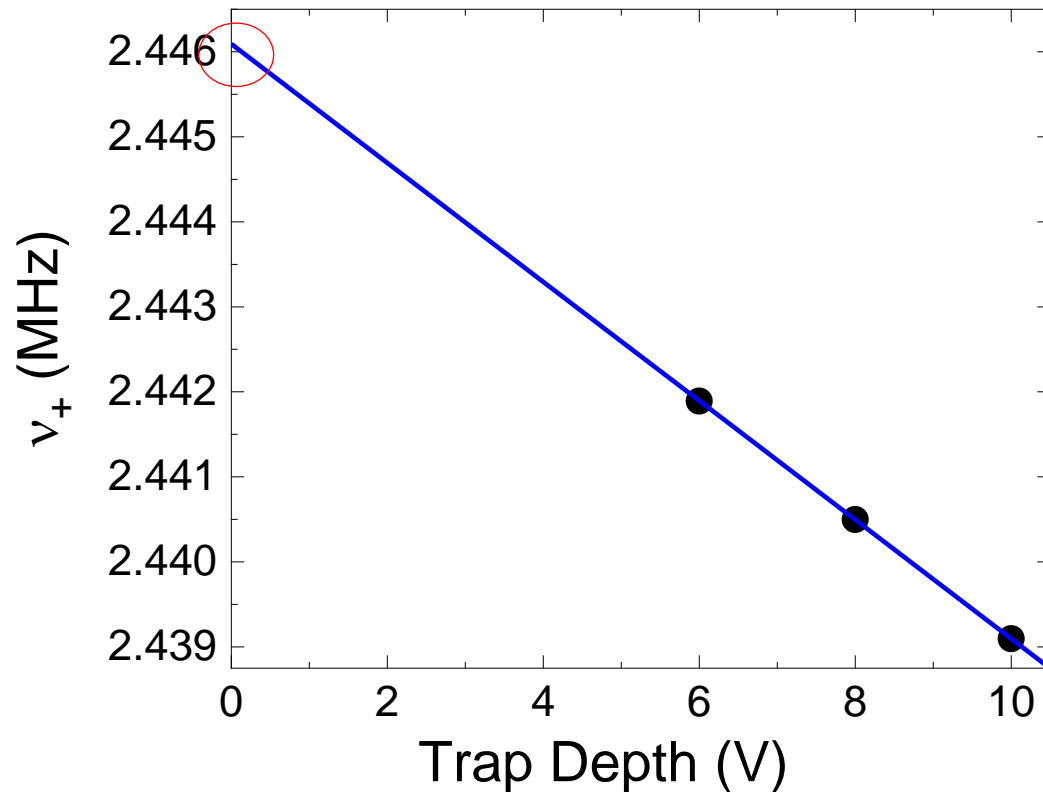

Short-term B stability

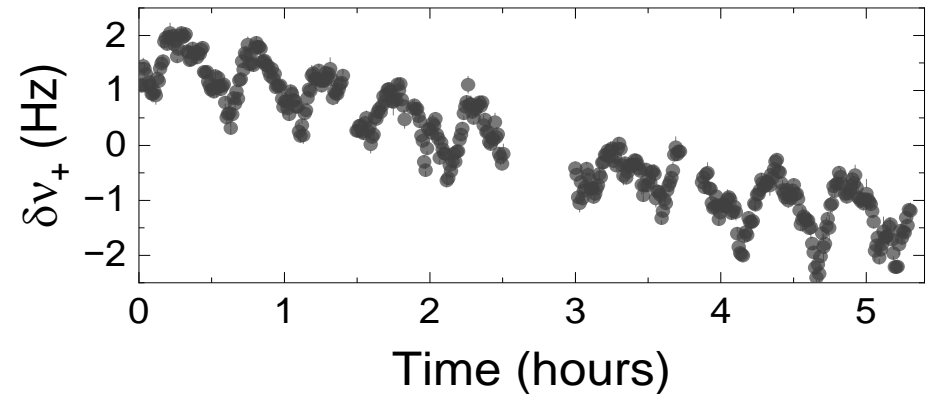

- 25 s per data point and possible to measure 5 s

Identification of the trapped ion



UNIVERSIDAD
DE GRANADA

Laboratorios
Singulares
UGR

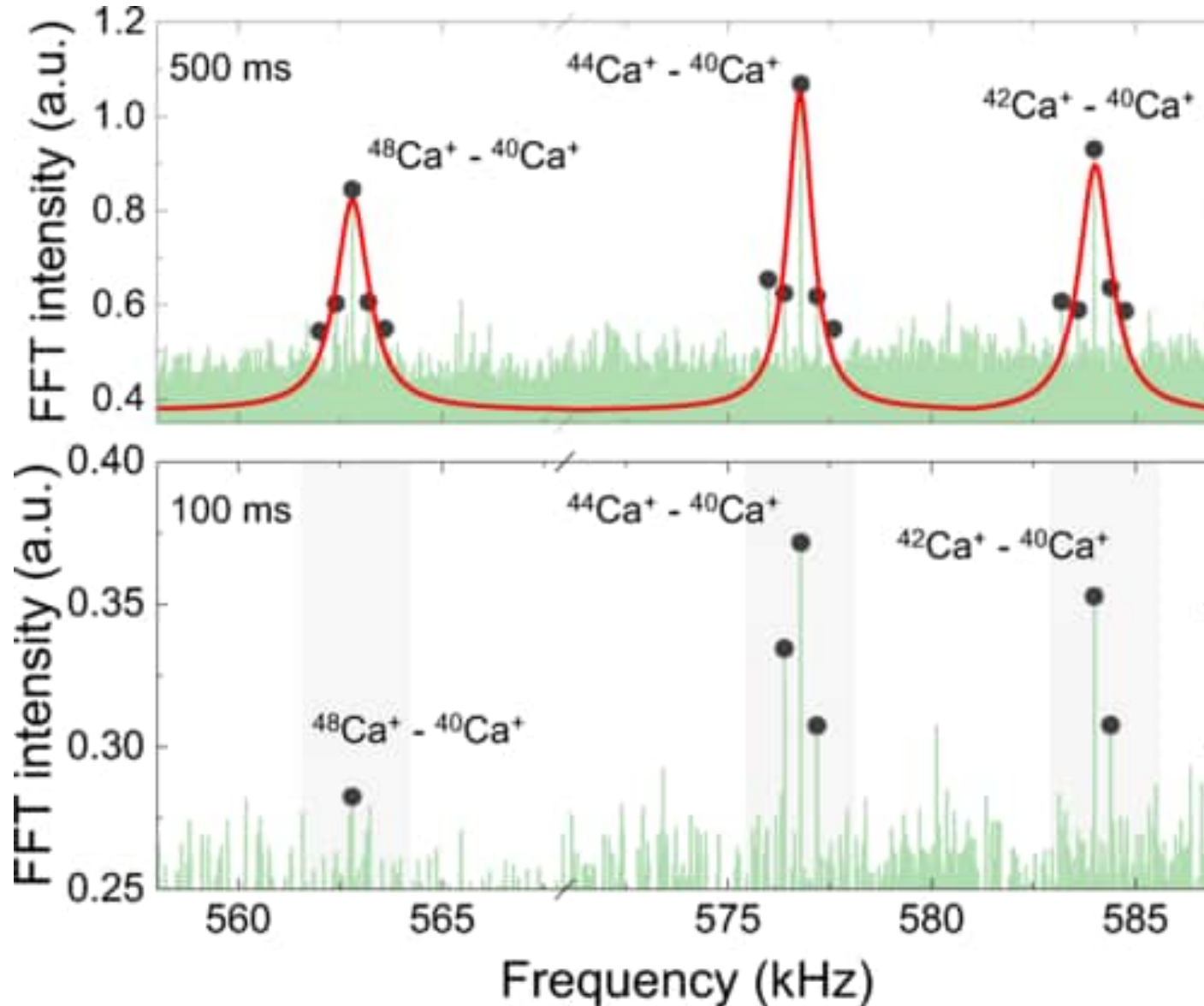

- Demonstrated for times below one second in the Paul trap

F. Domínguez, et al., PR
Research 6, 043255 (2024)

Injection of a second ion



UNIVERSIDAD
DE GRANADA



Laboratorios
Singulares
UGR

Trap Depth: 4 V

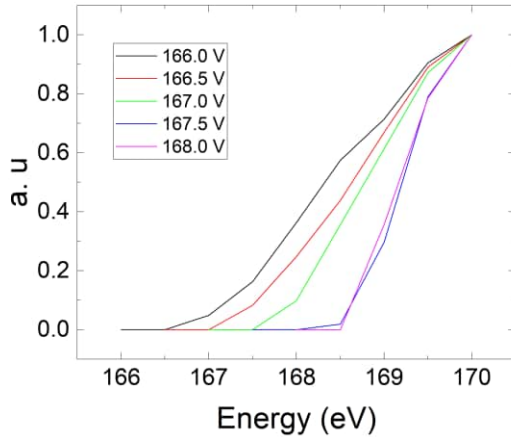

Trap Depth: 6 V

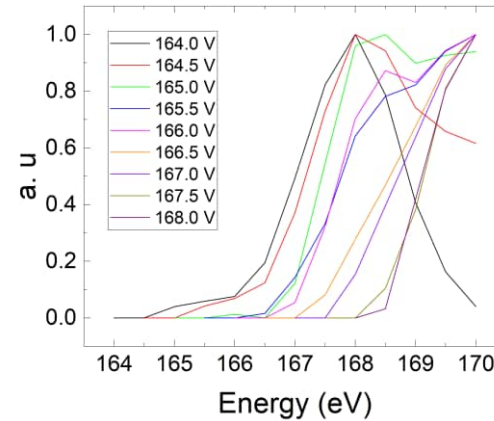

Trap Depth: 8 V

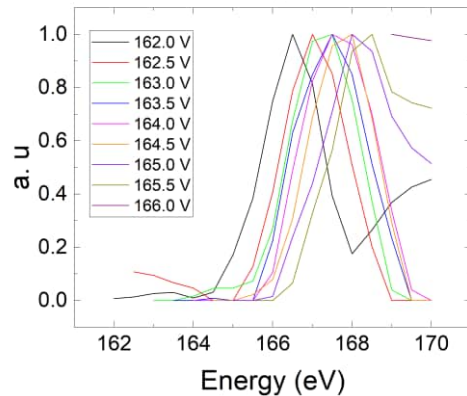

Trap Depth: 10 V

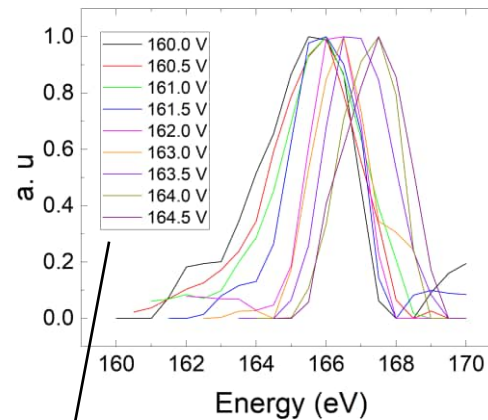

Best option!
Less ions inside the trap but
more energetic. Easy to keep
the already cooled

Asymmetry in potential well

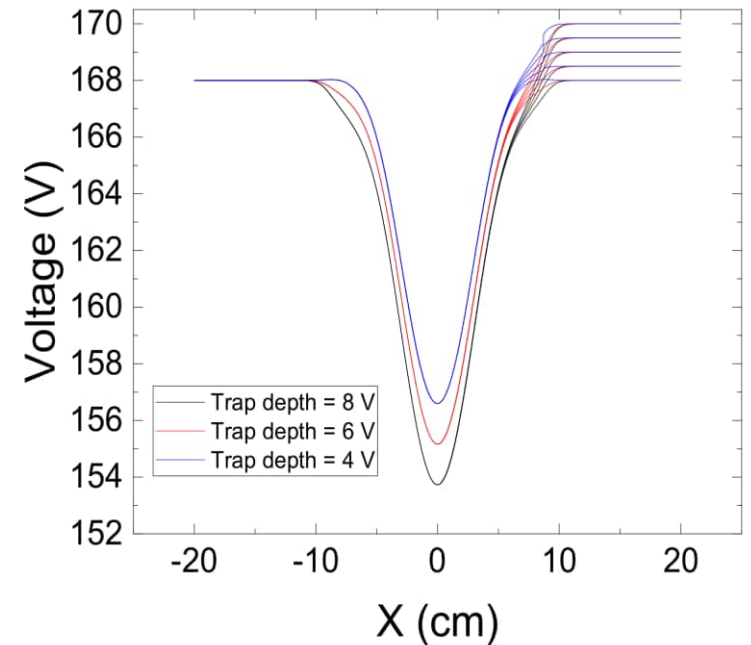

Lower Trap Depths: more dispersion
energy and more instability in already
cooled one

Trapping characterization hybrid crystal

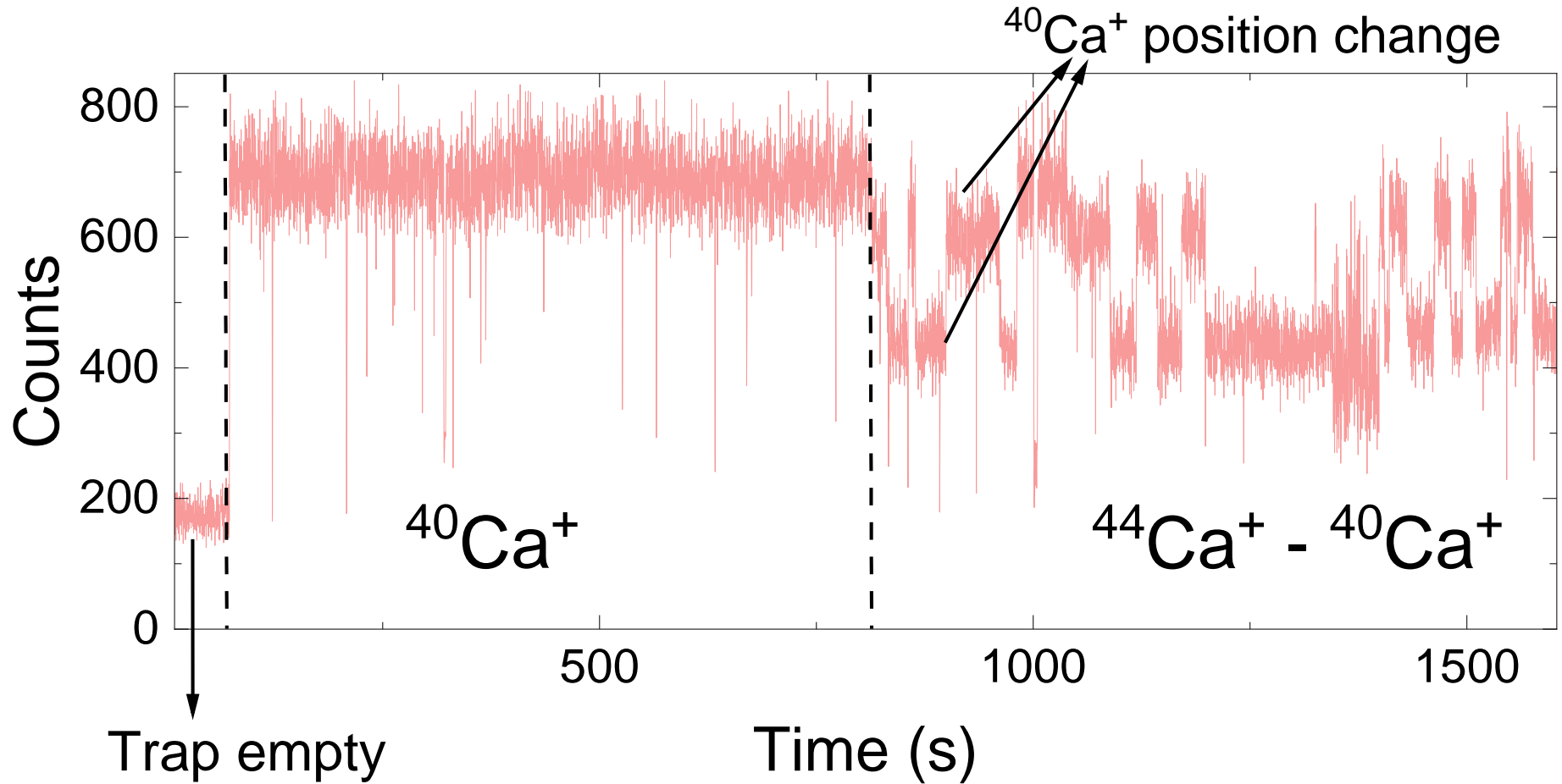

Trapping characterization hybrid crystal

Best sensor ion so far: the lightest one

Sensor ion $^{40}\text{Ca}^+$

- Mean cooling time:
 560 ± 220 s
- Efficiency ~ 60 %

Sensor ion $^{44}\text{Ca}^+$

- Mean cooling time:
 900 ± 200 s
- Efficiency < 20 %

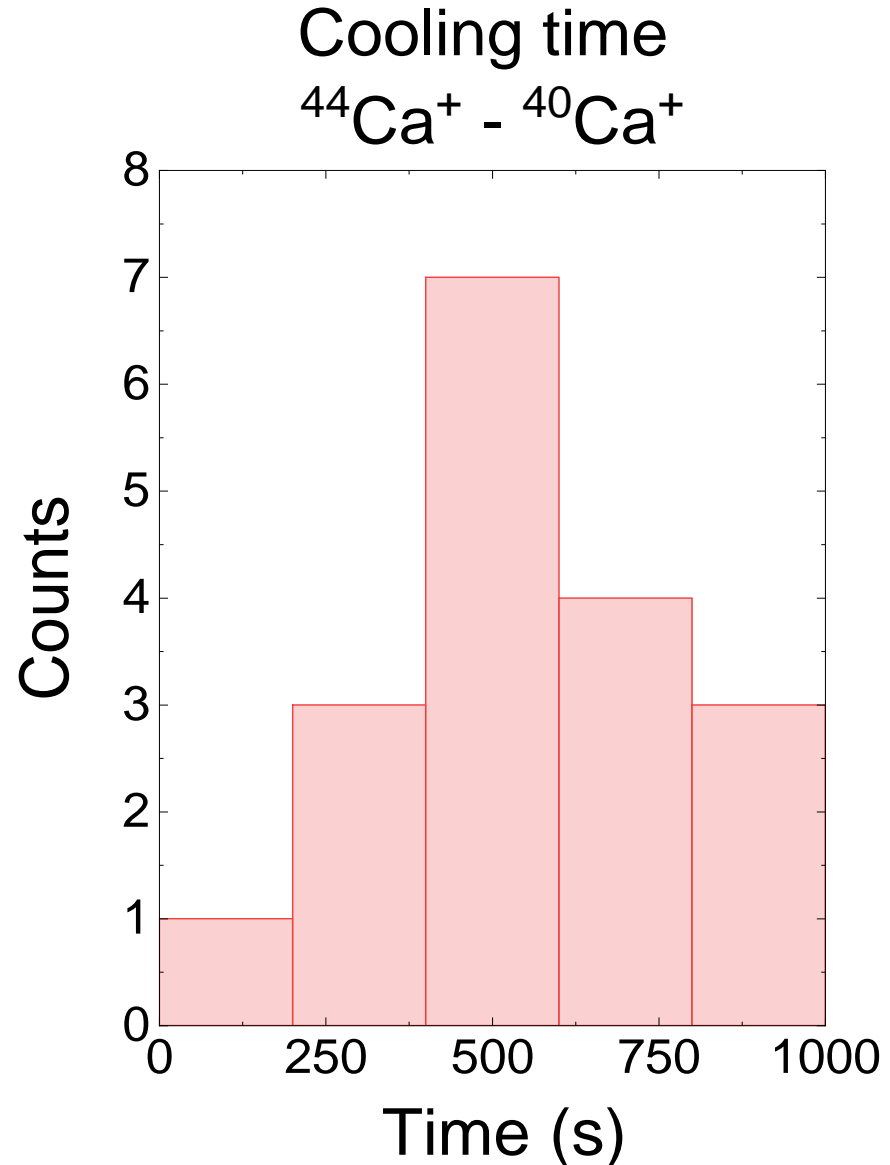

Identification of the hybrid crystal



UNIVERSIDAD
DE GRANADA



Laboratorios
Singulares
UGR

$^{40}\text{Ca}^+$ - $^{44}\text{Ca}^+$ identification

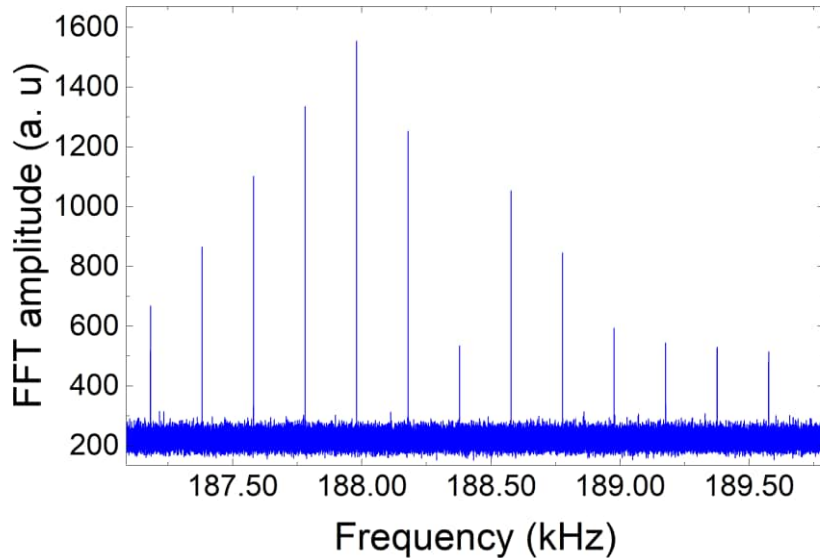

Excitation at different
frequencies

$^{40}\text{Ca}^+$ - CaO^+

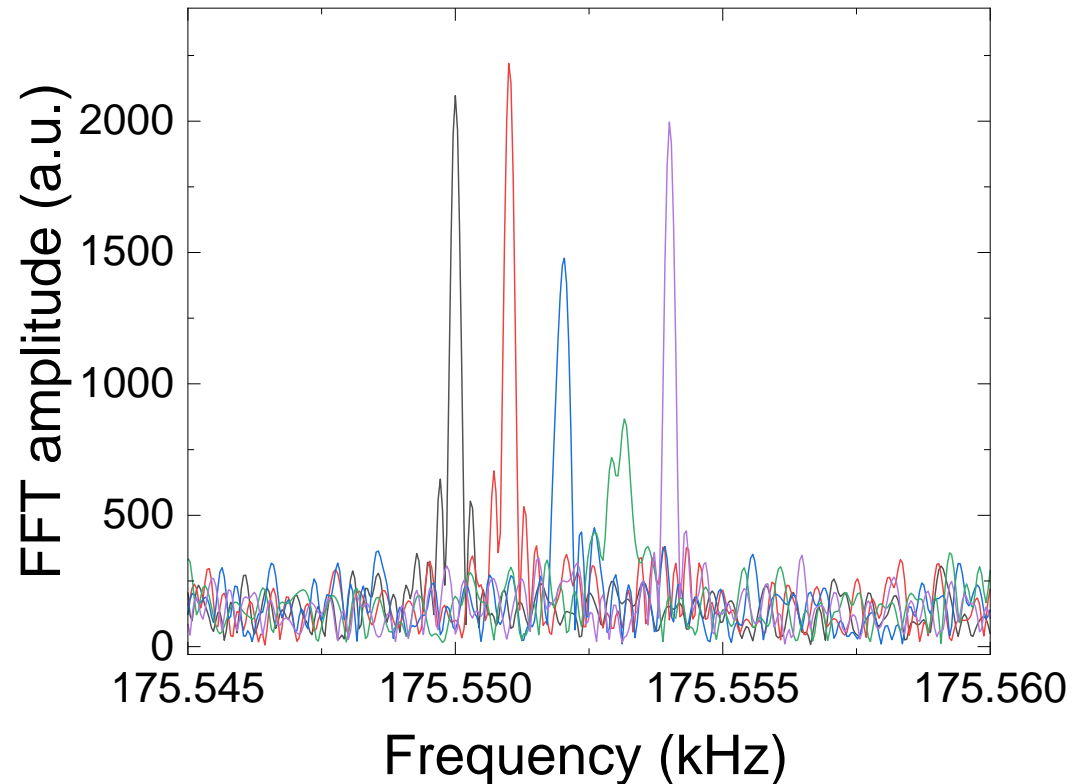

Summary and outlook

We can

- identify a single ion with the optical method.
- carry out sympathetic cooling with Ca isotopes produced outside the trap
- identify the unbalanced crystal with the optical method (still the axial frequency).

We work on

- improving cooling time by investigating the interaction with more ions
- demonstrating unambiguously the formation of the unbalanced crystal $^{40}\text{Ca}^+ - ^{232}\text{Th}^+$.

Thank you for your attention



Group at the University of Granada

Manuel Almagro
David Yousaf
Daniel Rodríguez

JGU/HIM-Mainz & GSI- Darmstadt

Francesca Giacoppo
Michael Block
Chris E. Düllmann
Sebastian Raeder
Jonas Stricker

MIT

Ronald Fernando García-Ruiz

ROA

Héctor Álvarez
Ignacio Cortés

Undergraduate students 2025/2026

Anna Schupeta (Master)
Diana de Miguel (Master)
Fernando Soto (Master)
Jesús Rodríguez (Bachelor)
Antonio M. Romero (Bachelor)
Jaime López
Vadim Egorov