

This project has received funding from the European Union's Horizon 2020 research and innovation programme under grant agreement No 951754.

FCC CRYOGENICS

STATUS, LAYOUT, AND IMPLEMENTATION STUDIES



CERN – Laurent Delprat
on behalf of the Cryogenics Group

Table of contents

1. Current status
2. Updated overall layout
3. Focus on FCC-ee SRF layout
 - Associated staging
 - Focus on ttbar
 - Sectorisation
4. Surface needs
 - Aboveground
5. Utilities needs update
 - Electrical
 - CV
6. FCC-ee operation modes
7. Upcoming steps

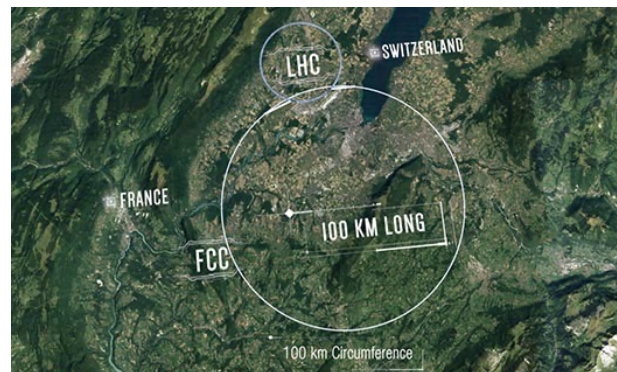
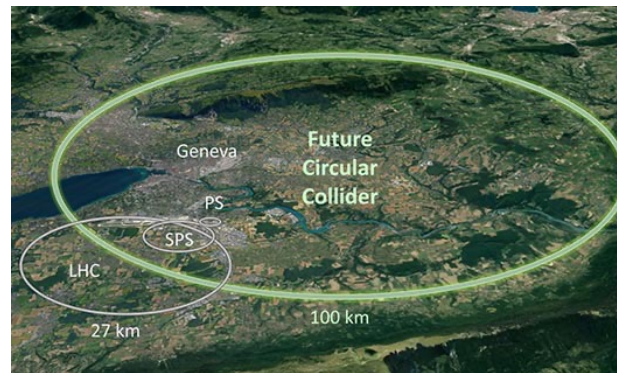



CURRENT STATUS

Status

M. Benedikt

2021				2022				2023				2024				2025			
Q1	Q2	Q3	Q4	Q1	Q2	Q3	Q4	Q1	Q2	Q3	Q4	Q1	Q2	Q3	Q4	Q1	Q2	Q3	Q4
Status reports & study planning				FCC Week & Review : implementation, baseline design, organisation, communication				FCCW followed by mid-term review: general coherency, cost updates				FCC Week & Review: key technology R&D programs				Release FSR Project cost update			

- **Narrowing down operating scenarios, CM design concept and heat loads together with SRF team.**
- **Understanding machine booster operation, its differences with the collider and its impacts on the cryogenics system.**
- **New baseline PA31-3.0 (25-01-23)**
 - LSS reduced from 2160 m to 2032 m.
 - Four scenarios for point L – shaft at 0 m, 300 m, 600 m and 1000 m of the IP.
 - Point H changed from asymmetric to symmetric.
 - FCC-ee cryoplants design and staging are being adapted.
- **Soon starting a second iteration of exchanges with industrial partners where focus will be put on FCC-ee.**



OVERALL ACCELERATOR LAYOUT FOR FCC

FCC-ee cryoplants layout – at ttbar stage

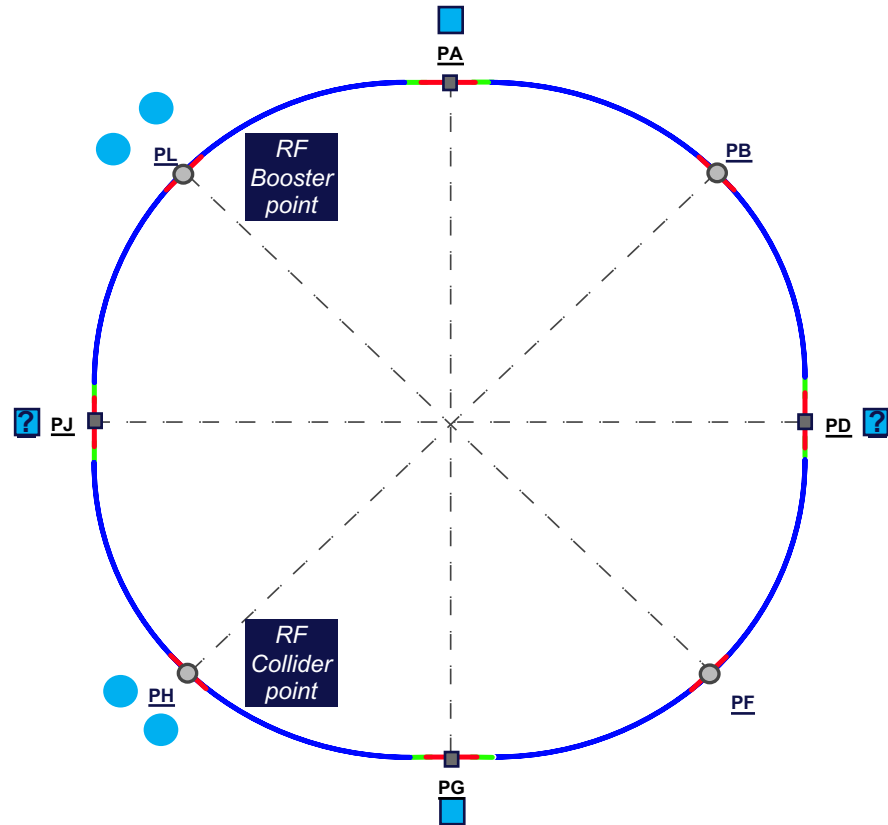

- → Technical Point
- → Sector RF Cryoplant

- → Experiment Point
- → Experiment Cryoplant



FOCUS: FCC CRYO-SRF LAYOUT

FCC-ee cryogenics for ttbar machine – heat loads

- **All collider cryomodules located at Point H**
 - 60 kW @ 4.5 K to be extracted according to the updated RF heat load estimations* (15-02-23)
 - Divided in 65 (400 MHz) cryomodules.
 - 20 kW @ 2 K to be extracted according to the updated RF heat load estimations* (15-02-23)
 - Divided in 109 (800 MHz) cryomodules.
 - 2 K heat load is in the current technological limits.
 - Refinement of all values and iteration with industry is needed.
 - Collider point H cryo-RF system is symmetric – **1940 m in total**.
- **All booster cryomodules located at Point L**
 - 9 kW @ 2 K to be extracted according to the reduced RF heat load estimations* (15-02-23)
 - Divided in 150 (800 MHz) cryomodules.
 - Booster point L cryo-RF system may not be symmetric (4 scenarios) – **1300 m in total**.

**margin factor of 30% is considered on cryo side due to RF heat load uncertainties and to embed losses from the cryo distribution.*



FOCUS: FCC CRYO-SRF LAYOUT

Point H

Point H

PH located on the French territory
PA31-3.0: shaft is assumed at nominal point

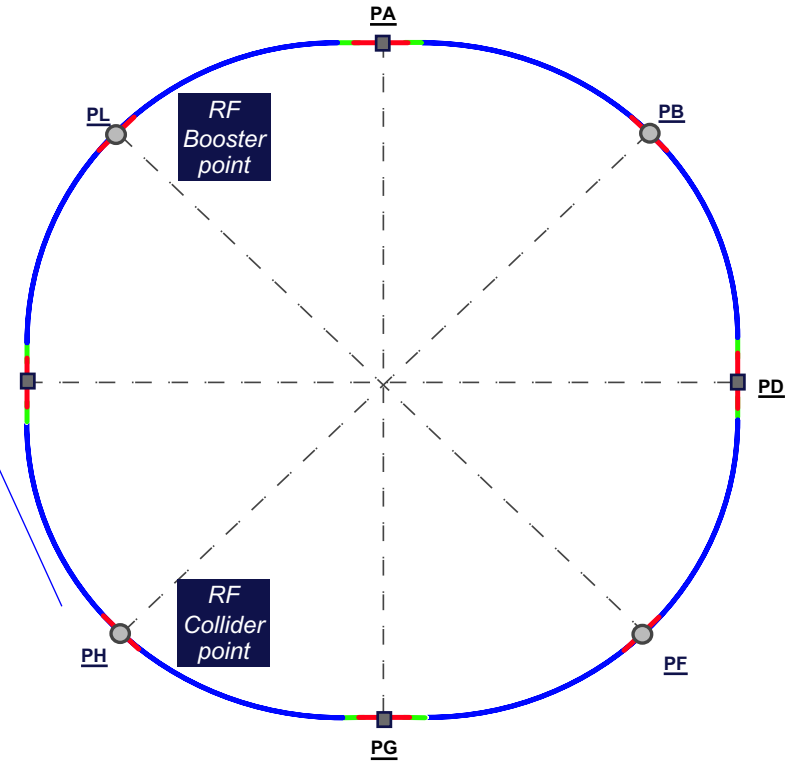
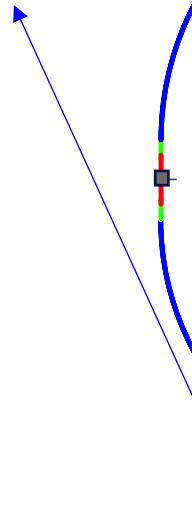
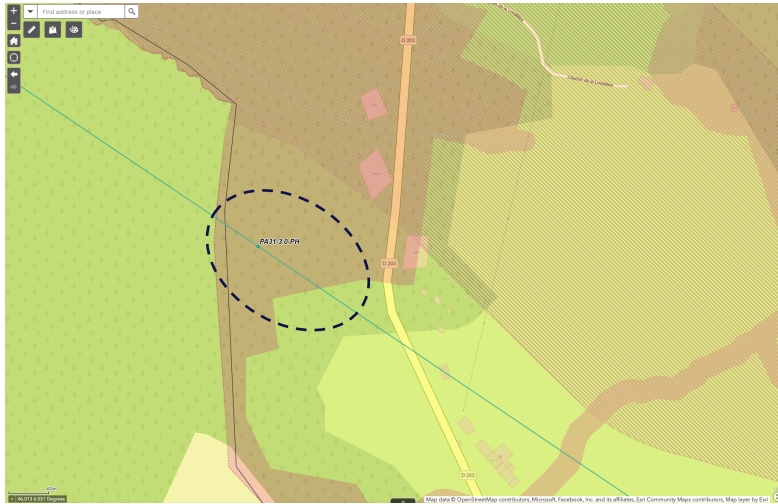

Symmetric point containing the collider SRF section

FCC-ee cryoplants at point H (ttbar)

- Service cavern & LSS center are aligned
- CM are shared **symmetrically**
- CM organized to minimize QRL

- **EM separators have to be included within the LSS too.**
- LSS total length is of 2032 m.

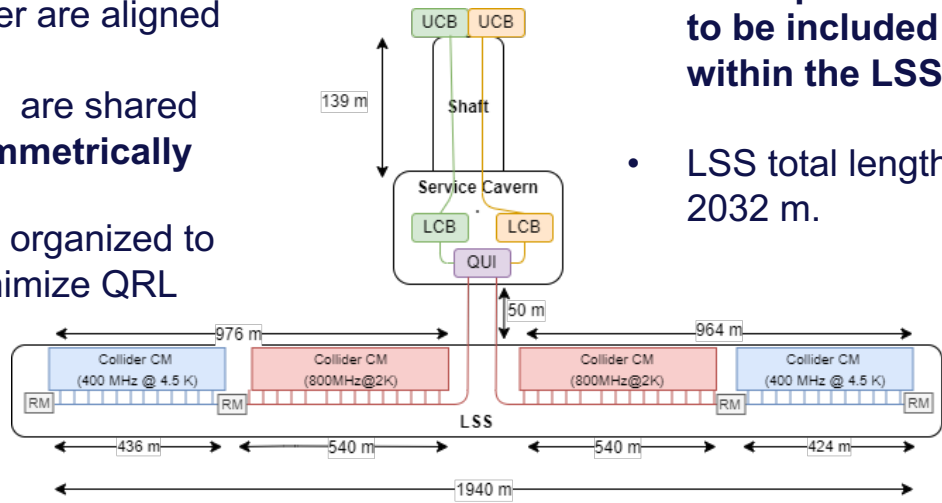

QRL Header & Process values	Diameter (mm)
A : 1.3 bar , 2.2 K ($\Delta P=25$ mbar)	72
B : 30 mbar , 2 K ($\Delta P=2$ mbar)	320
C: 3 bar, 4.6 K ($\Delta P=130$ mbar)	110
D: 1.3 bar, 4.5 K ($\Delta P=70$ mbar)	185
E: 20 bar, 50 K ($\Delta P=10$ mbar)	80
F: 18 bar, 75 K ($\Delta P=15$ mbar)	80
Vacuum jacket (400MHz)	550*
Vacuum jacket (800 MHz)	750*

* +100 mm for bellows and flanges

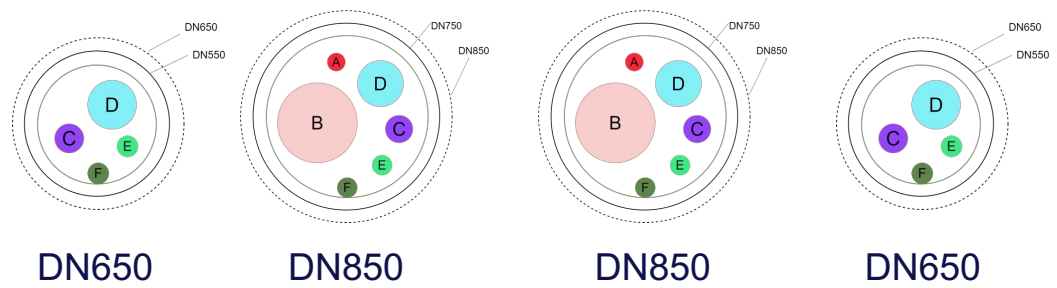

- **RF-cryo CM string with baseline scenario fits within the LSS.**
 - Alternative scenarios under discussions
- EM separators may not have enough space. To be checked with respective teams. Source: <https://indi.to/WpWr7>



FCC-ee cryoplants at point H (ttbar)

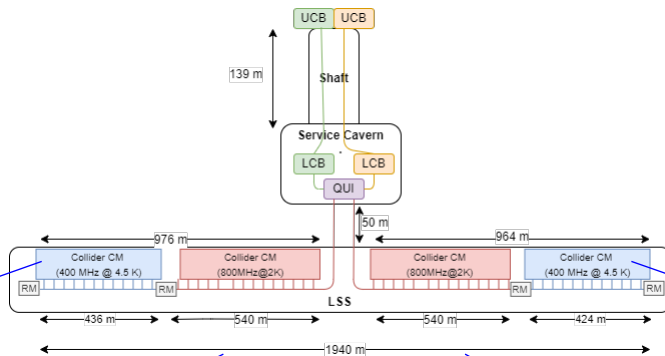

CM = 187

- 33 CM @ 4.5 K
- 11.4 m/CM
- 4 cavities/CM
- 8 cells/CM

- 61 CM @ 2 K
- 7.5 m/CM
- 4 cavities/CM
- 20 cells/CM

- 61 CM @ 2 K
- 7.5 m/CM
- 4 cavities/CM
- 20 cells/CM

- 32 CM @ 4.5 K
- 11.4 m/CM
- 4 cavities/CM
- 8 cells/CM

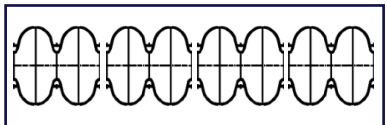
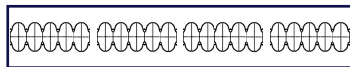
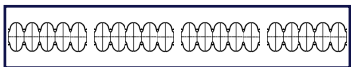
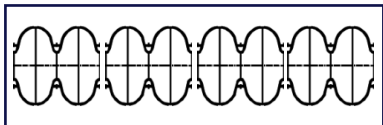

Diagrams not to scale

FCC-ee cryoplants at point H: staging

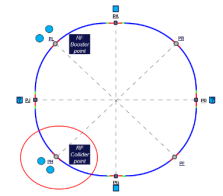

- **Staging at point H**
 - Increased staging complexity.

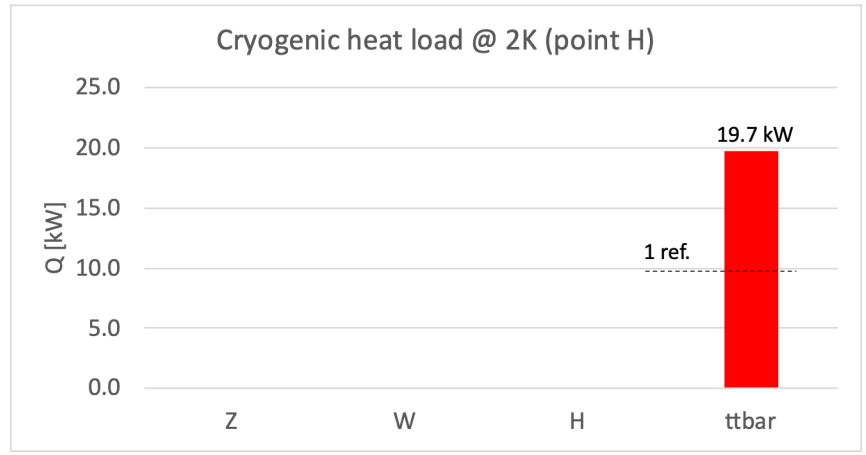
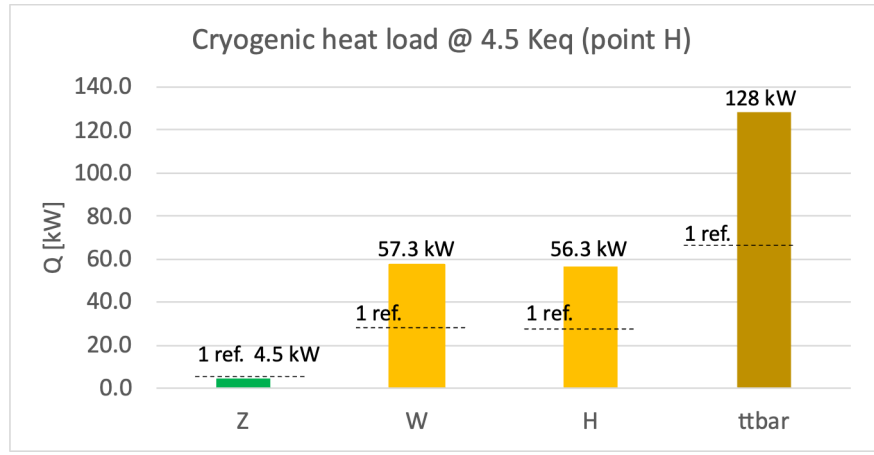
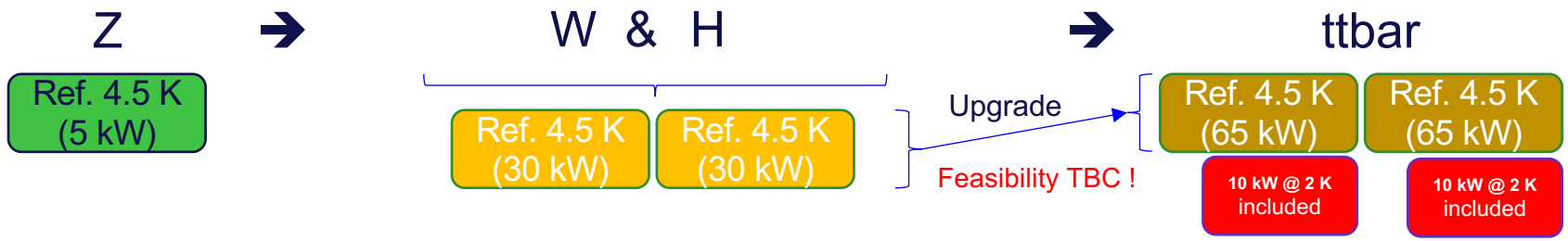

FCC-ee CM sectorisation at point H

- Cryo-RF working group has been set in January 2023 to address the cryomodule design of the cavities.
- Current discussions are focused on the sectorization concept of the 2 K Cryomodules for the 800 MHz bulk Nb cavities.

• Several options are being weighted:

- Fully segmented approach
 - Ex: ESS or PIP-II

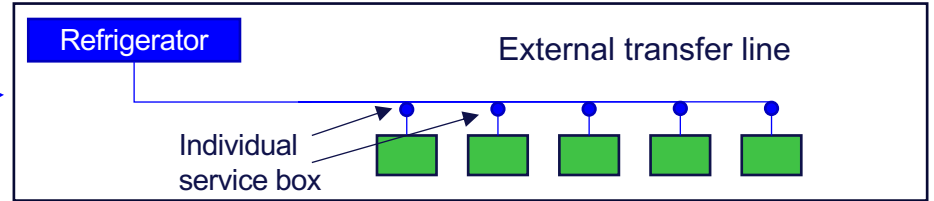

- Hybrid approach

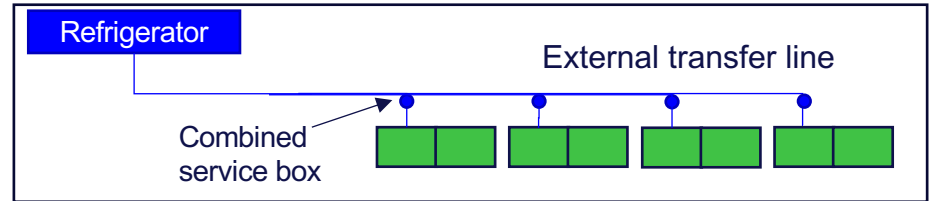

- Continuous/Integrated cryostat approach
 - Ex: XFEL or LCLS-II

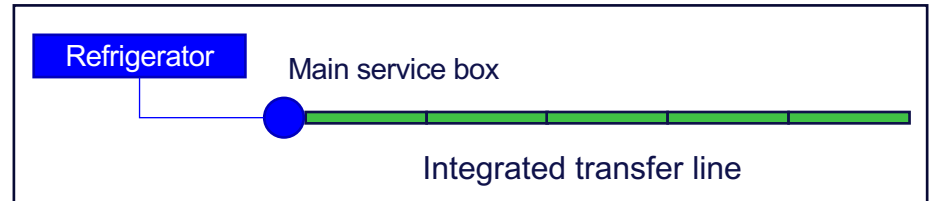

- Exchange with other teams that addressed the same topic will be started.



FOCUS: FCC CRYO-SRF LAYOUT

Point L

Point L

PL located on the French territory

PA31-3.0: shaft location is uncertain. Different scenarios to be assessed:

- **S1: Shaft at nominal point**
 - **S2: Shaft at 300 m**
 - **S3: Shaft at 600 m**
 - **S4: Shaft at 900 m**
- Feasibility

↓

Preference

↑

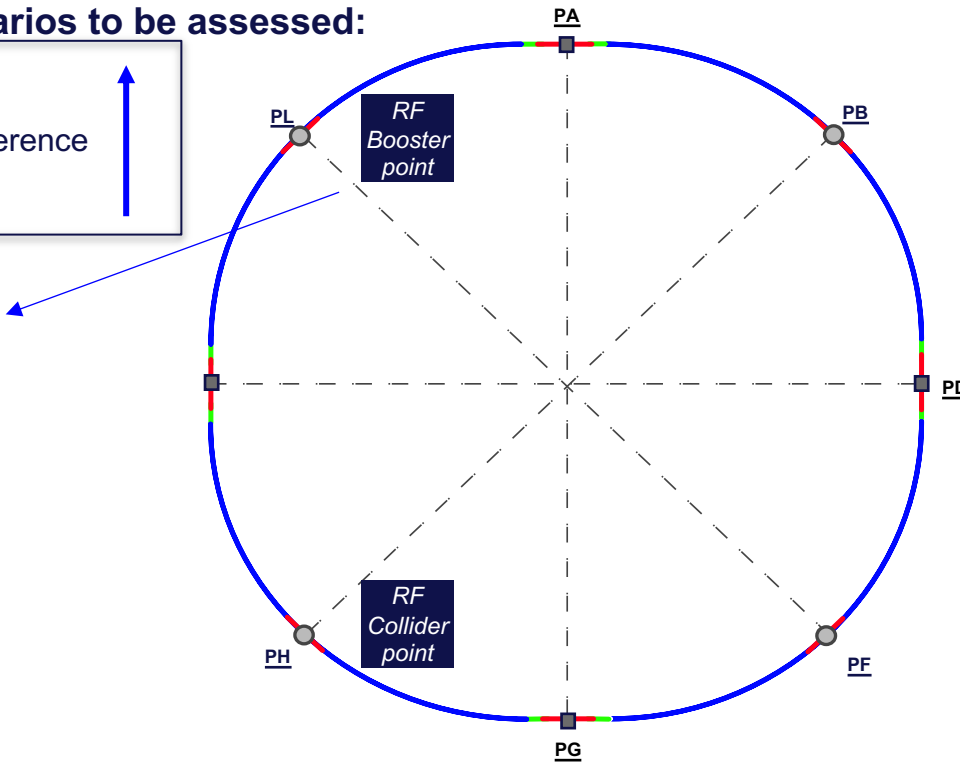
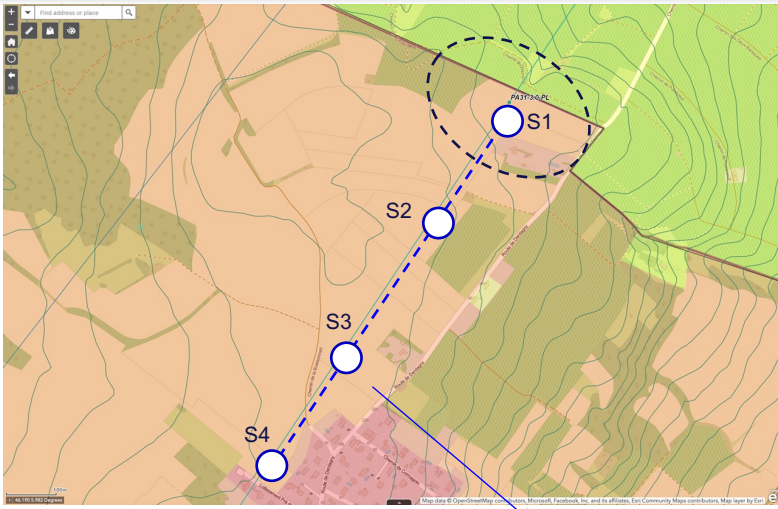

Difficult point containing the booster SRF section – smaller site

FCC-ee cryoplants at point L (ttbar) - Comparative

QRL Header	Max. Diameter (mm)		
	S1 / S2	S3	S4
A/A1 : 1.3 bar , 2.2 K ($\Delta P=25$ mbar)	55	65	80
B/B1 : 30 mbar , 2 K ($\Delta P=2$ mbar)	245	290	360
C : 3 bar, 4.6 K ($\Delta P=130$ mbar)	-	-	-
D : 1.3 bar, 4.5 K ($\Delta P=70$ mbar)	-	-	-
E : 20 bar, 50 K ($\Delta P=5$ mbar)	60	80	90
F : 18 bar, 75 K ($\Delta P=10$ mbar)	60	80	90
Vacuum jacket right	550*	600*	700*
Vacuum jacket left	550*	500*	
QRL Outer envelope	650	700	800

* +100 mm for bellows and flanges

Direct impact on tunnel diameter



- S1 and S2 can be dealt as one when dealing with industrial partners. No difference for the cryo system.
- S3 offers the trickiest staging due to its asymmetry.
- S4 implies the biggest QRL, that is, the hardest integration.
- Site location remains to be discussed with the commune in the coming months.
- Cryo will be ready for any of the outcomes.

FCC-ee cryoplants at point L: staging

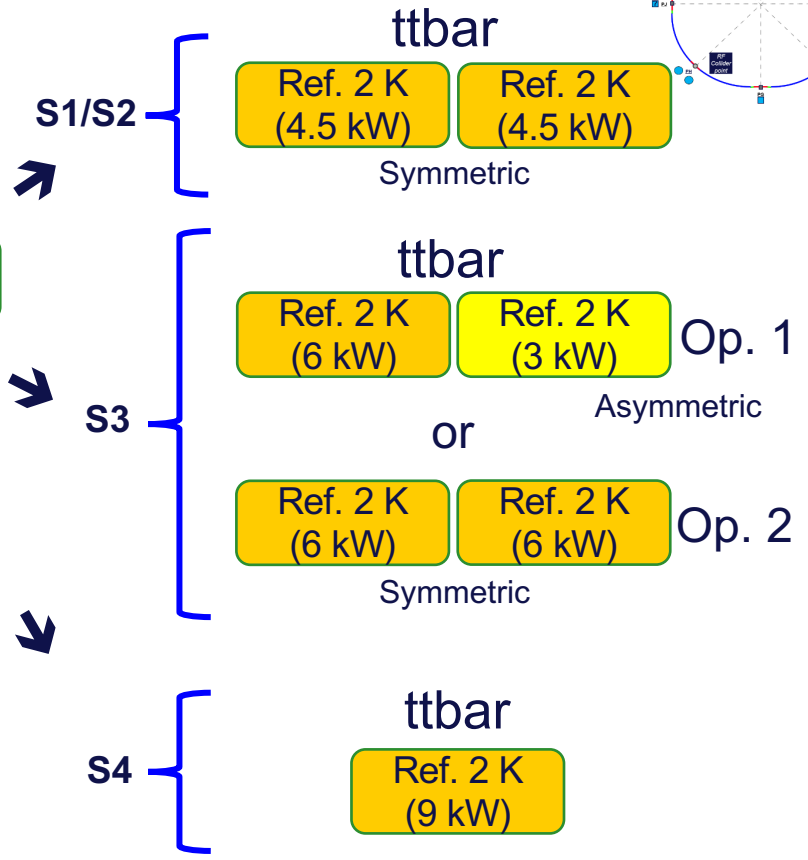
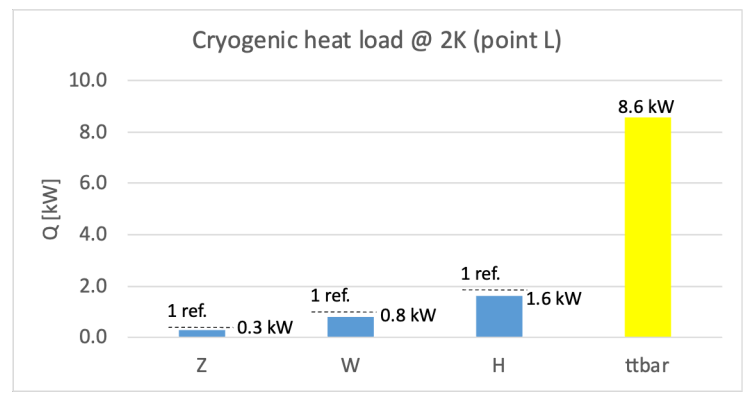
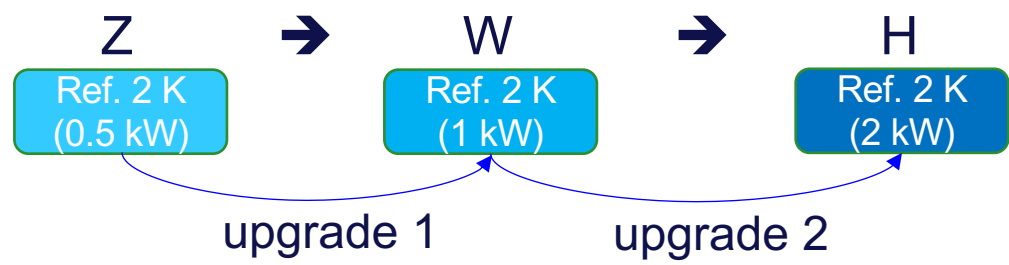
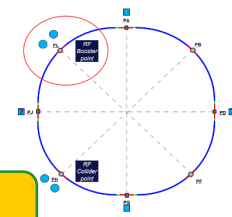

Helium inventory

Assumption: **40 kg LHe per CM**

Point L/S4	Z	W	H	ttbar
Cryomodules	0.3 ton	0.6 ton	1.1 ton	6 ton
Distribution (QRL)	1.4 ton	1.4 ton	1.4 ton	1.4 ton
Cryoplants	0.1 ton	0.1 ton	0.2 ton	0.6 ton
Total	1.8 ton	2.1 ton	2.7 ton	8 ton

Point H	Z	W	H	ttbar
Cryomodules	2.2 ton	2.6 ton	2.6 ton	7.5 ton
Distribution (QRL)	4.3 ton	4.3 ton	4.3 ton	4.3 ton
Cryoplants	0.2 ton	2.1 ton	2.1 ton	4.5 ton
Total	6.7 ton	9 ton	9 ton	16.3 ton

➤ **Total helium inventory for FCC-ee (ttbar) ~ 25 ton**

Alternative cavities cooling scenarios

- A large fraction of the helium inventory is taken by the cryomodules baseline design scenario
- An important reduction could be achieved with the following R&D efforts that are currently ongoing at CERN:

1) Implementation of a dry-cavity cooling technique for the 400 MHz baseline elliptical cavities

Concept:

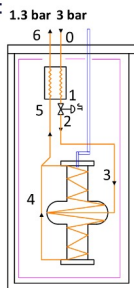

Radiofrequency 1.3 GHz prototype cavity with soldered cooling capillaries

Cryolab team

- Amount of needed He could be drastically reduced
- Interesting option to improve trapped flux issue
- Purity of He is critical due to the small cooling channel diameter
- Promising solution for standalone small facilities
- Tests bench facility currently under implementation

2) Exchange of the baseline elliptical cavities with the 600 MHz SWELL cavities

Concept:

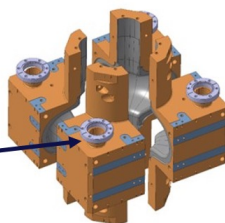
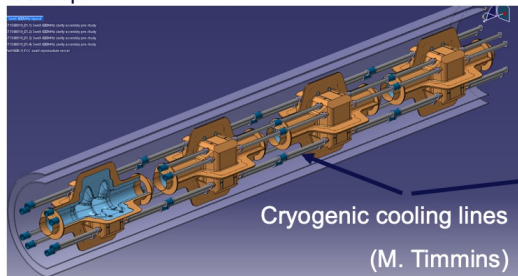

- One cavity \approx 800 kg of Cu.
- Cryogenic cooling by drilled channels.
- CM number reduction by 16 %.
- Same type of cavity for Z, W and H stages.
- Tests coming soon.



SURFACE NEEDS

FOR CIVIL ENGINEERING

Surface requirements for cryo

- Aboveground surface needs per point:

Estimations based on industrial studies for FCC-hh @ CDR baseline and LHC experience.

Surface in m2		Point A & G		Point B & F		Point D & J		Point H		Point L	
		ee (ttbar)	hh	ee (ttbar)	hh	ee (ttbar)	hh	ee (ttbar)	hh	ee (ttbar)	hh
Surface in m2	Compressor station building	430	4300	x	6400	N/A	N/A	6400	6400	3200	6400
	Cold box building	x	400	x	800			800	800	400	800
	LN2 storage	42	42	x	42			42	42	42	42
	GHe storage	400	2000	x	2900			1620	2900	810	2900
	LHe storage	x	1080	x	2200			x	2200	x	2200
	Total aboveground	872	7822	x	12342			8862	12342	4452	12342

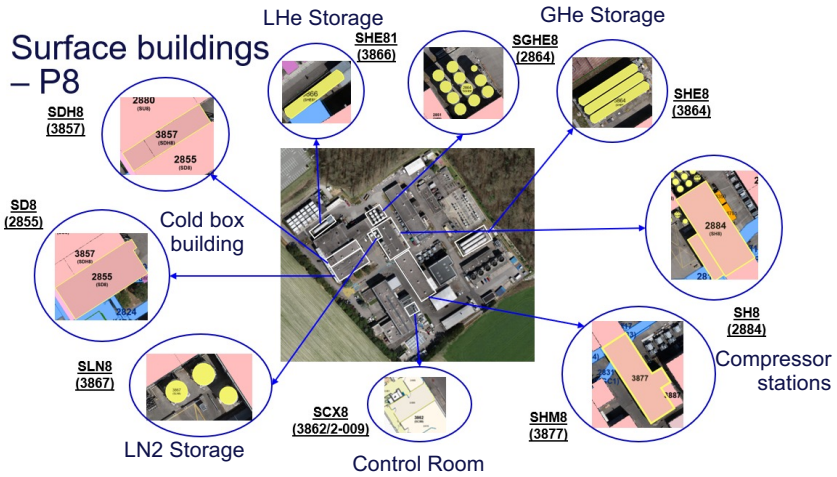
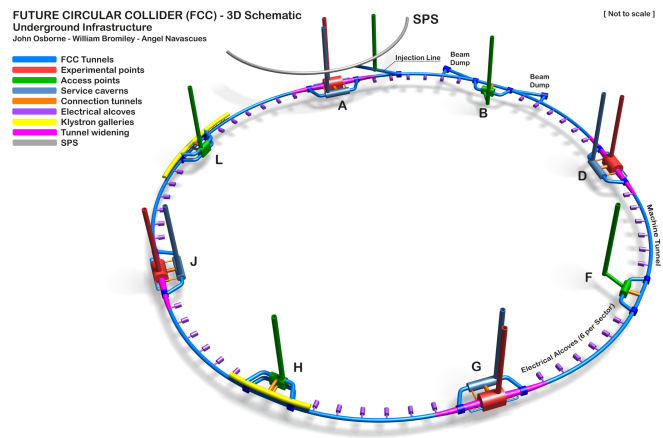

LHC P8 total cryo area of about 4600 m2.



UTILITIES NEEDS

Revised cooling water needs for FCC-ee

From the CDR to 2023 update

- **2019 CDR:**
 - Underground areas: 1.8 MW for point D /// 1.8 MW for point J
 - (2 * 12 kW @ 2 K installed at each point)
 - Surface areas: 27 MW for point D /// 27 MW for point J
 - (2 * 21.4 kW @ 4.5 K installed at each point)

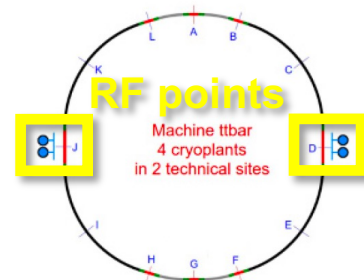

- **2023 update:**
 - Underground areas @ ttbar :
 - **0.7 MW** for point L (2 * 6 kW @ 2 K installed)
 - **1.5 MW** for point H (2 * 12 kW @ 2 K installed)
 - Surface areas:
 - **20 MW** for point L (2 * 6 kW @ 2 K installed)
 - **82 MW** for point H (2 * 65 kW @ 4.5 K installed)

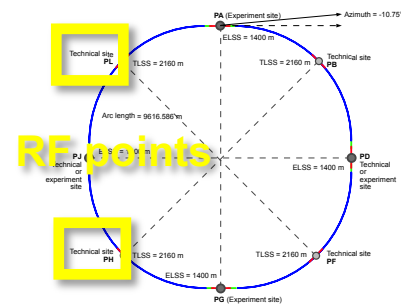

Waste heat recovery assessment to be started with CV.

13 MW per cryo-point in the LHC

Electricity power requirements – Installed power

- Three scenarios based on warm compressors performance:
 - **Conservative:** 230 Wel/W or 28.8 % of Carnot efficiency (LHC-like – CDR values) ⇔ **the baseline!**
 - **Intermediate:** 210 Wel/W or 31.5 % of Carnot efficiency (with an optimized process) ⇔ **appears not achievable**
 - **Optimistic:** 170 Wel/W or 39 % of Carnot efficiency (with centrifugal compressors) ⇔ **strong R&D effort needed**



In “high” mode 

	PH [MW]	PL [MW]	Total [MW]
Z	1.2 / 1.1 / 0.9	0.3 / 0.3 / 0.3	1.5 / 1.4 / 1.2
W	13.8 / 12.6 / 10.2	0.8 / 0.7 / 0.6	14.6 / 13.3 / 11.4
H	13.8 / 12.6 / 10.2	1.6 / 1.5 / 1.2	15.4 / 14.1 / 12.1
ttbar	30 / 27.3 / 22.1	7.8 / 7.1 / 5.8	37.8 / 34.4 / 27.9

-26% of consumption with centrifugal compressors! R&D needed.



FCC OPERATION MODES

Operation modes – Typical year

- **Phases in a typical year – 365 days**
 - Shutdown phase – 120 days (33%)
 - The machine is stopped and open for upgrade works, maintenance and repairs.
 - Operation phase – 245 days (67%)
 - Hardware and beam commissioning – 30 days
 - All systems are restarted and tested before operation.
 - Physics operation – 185 days
 - Beam is stable and collides for experiments.
 - Technical stops – 10 days
 - Planned stops during operation to perform maintenance and repairs.
 - Machine development – 20 days
 - Planned activities with beam operation to improve beam performance.
- **Availability target – 80 % of physics operation**
- **The modes will impact the design of the cryoplants and their energy consumption**

Source: CDS 2645151



A total of 14 years of expected life-cycle:

- 4 years in Z stage
- 2 years in W stage
- 3 years in H stage
- 5 years in ttbar stage

Operation modes – Typical year

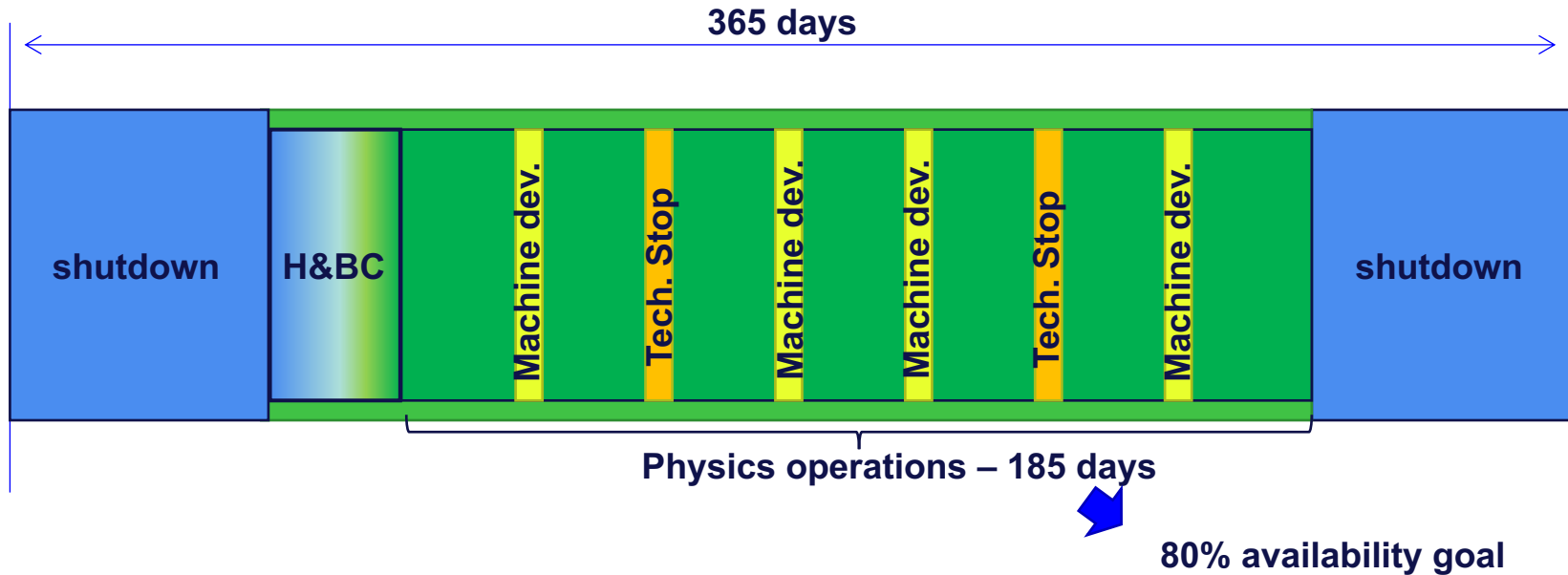



UPCOMING STEPS

Upcoming steps

- Freeze the geometry of the RF access points
 - Points H & L, relative position of the access shaft wrt the LSS-center
- Freeze the RF layout
 - Number of CMs, heat loads
- Finalize staging proposal after booster filling from scratch mode is clarified
- Define the operation modes of the cryoplants according to the machine modes
- Update the feasibility study, FCC week 23' and Mid-term review
- Investigate the open points (safety aspects, size of the cold box elements)

THANK YOU FOR YOUR ATTENTION



SPARES

FCC-ee cryoplants at point L (ttbar) – S1

$L_{LSS} = 2032\text{ m}$

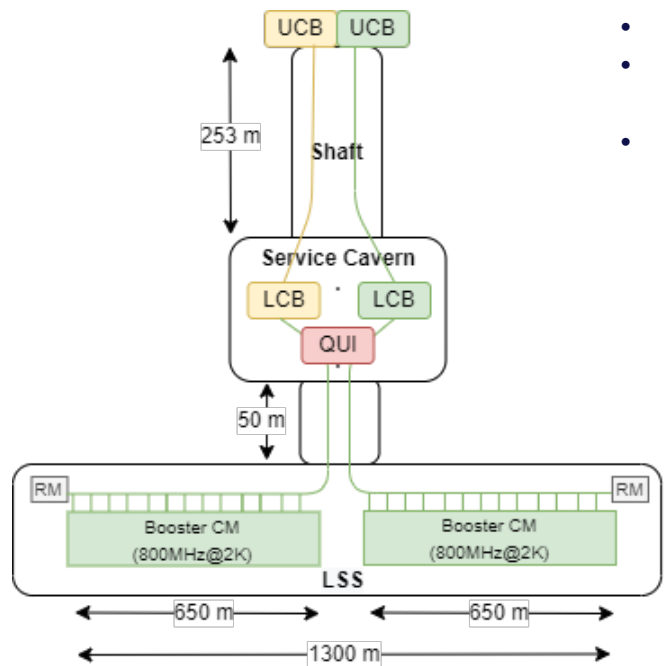

- S1: Shaft & Service cavern are centered at LSS center.
- The cryomodules are equally distributed on both sides of the shaft in order to reduce the QRL size.
- Straightforward staging with good operability and maintainability option.

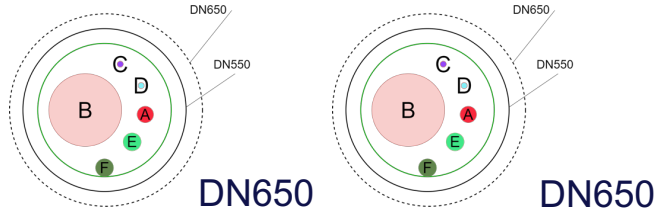

QRL Header	Diameter (mm)
	S1
A: 1.3 bar , 2.2 K ($\Delta P=25\text{ mbar}$)	55
B : 30 mbar , 2 K ($\Delta P=2\text{ mbar}$)	245
C: 3 bar, 4.6 K ($\Delta P=130\text{ mbar}$)	-
D: 1.3 bar, 4.5 K ($\Delta P=70\text{ mbar}$)	-
E: 20 bar, 50 K ($\Delta P=5\text{ mbar}$)	60
F: 18 bar, 75 K ($\Delta P=10\text{ mbar}$)	60
Vacuum jacket right	550*
Vacuum jacket left	550*

* +100 mm for bellows and flanges

FCC-ee cryoplants at point L (ttbar) – S2

$L_{LSS} = 2032\text{ m}$

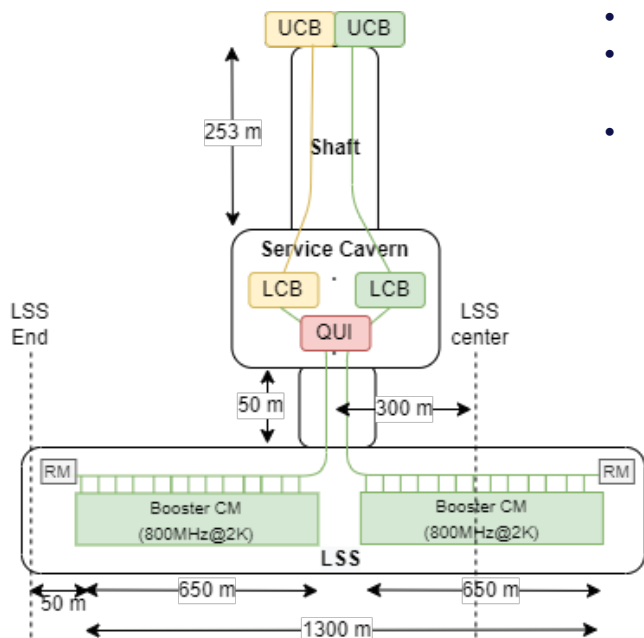

- S2: Shaft & Service cavern are shifted 300m from the LSS center.
- The cryomodules are **still** equally distributed on both sides of the shaft in order to reduce the QRL size.
- Straightforward staging with good operability and maintainability option.

QRL Header	Diameter (mm)
	S2
A: 1.3 bar , 2.2 K ($\Delta P=25\text{ mbar}$)	55
B : 30 mbar , 2 K ($\Delta P=2\text{ mbar}$)	245
C: 3 bar, 4.6 K ($\Delta P=130\text{ mbar}$)	-
D: 1.3 bar, 4.5 K ($\Delta P=70\text{ mbar}$)	-
E: 20 bar, 50 K ($\Delta P=5\text{ mbar}$)	60
F: 18 bar, 75 K ($\Delta P=10\text{ mbar}$)	60
Vacuum jacket right	550*
Vacuum jacket left	550*

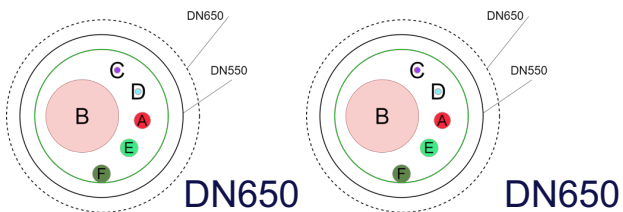

* +100 mm for bellows and flanges

FCC-ee cryoplants at point L (ttbar) – S3

$L_{LSS} = 2032\text{ m}$

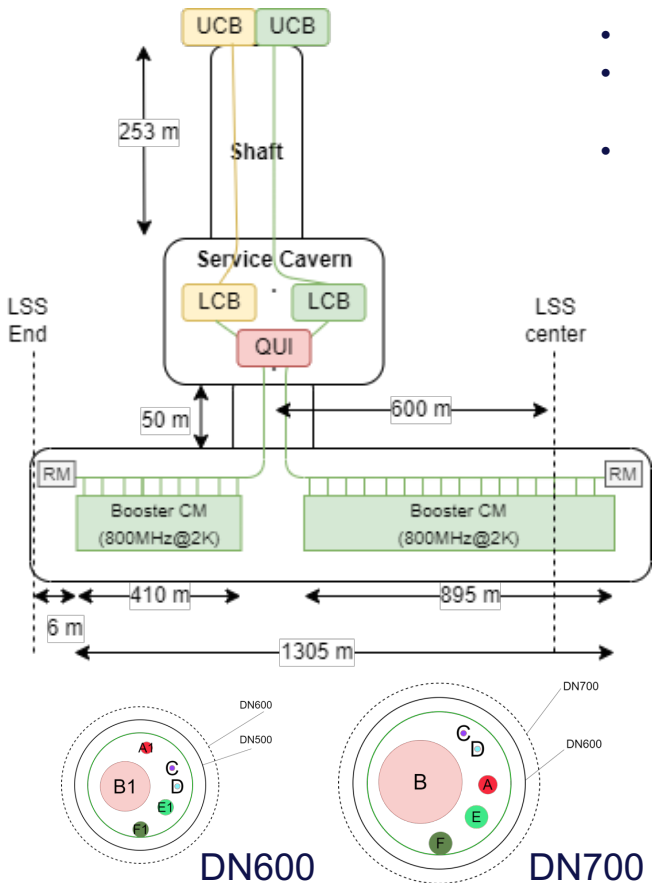

- S3: Shaft & Service cavern are shifted 600m from the LSS center.
- The cryomodules are **not** equally distributed on both sides of the shaft as LSS end is too close. Distribution is optimised such that QRL size is minimal.
- Staging becomes more challenging as heat loads are not symmetric.

QRL Header	Diameter (mm)
	S3
A/A1 : 1.3 bar , 2.2 K ($\Delta P=25\text{ mbar}$)	65/45
B/B1 : 30 mbar , 2 K ($\Delta P=2\text{ mbar}$)	290/190
C : 3 bar , 4.6 K ($\Delta P=130\text{ mbar}$)	-
D : 1.3 bar , 4.5 K ($\Delta P=70\text{ mbar}$)	-
E : 20 bar , 50 K ($\Delta P=5\text{ mbar}$)	80
F : 18 bar , 75 K ($\Delta P=10\text{ mbar}$)	80
Vacuum jacket right	600*
Vacuum jacket left	500*

* +100 mm for bellows and flanges

FCC-ee cryoplants at point L (ttbar) – S4

$L_{LSS} = 2032 \text{ m}$

- S4: Shaft & Service cavern are at the end of the LSS.
- Cryomodules can not be distributed. One long string is the only possibility.
- Less cryoplants are needed at the cost of operability and maintainability.

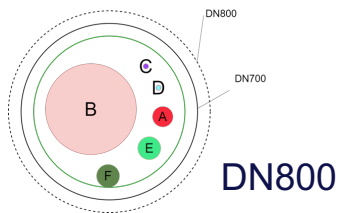
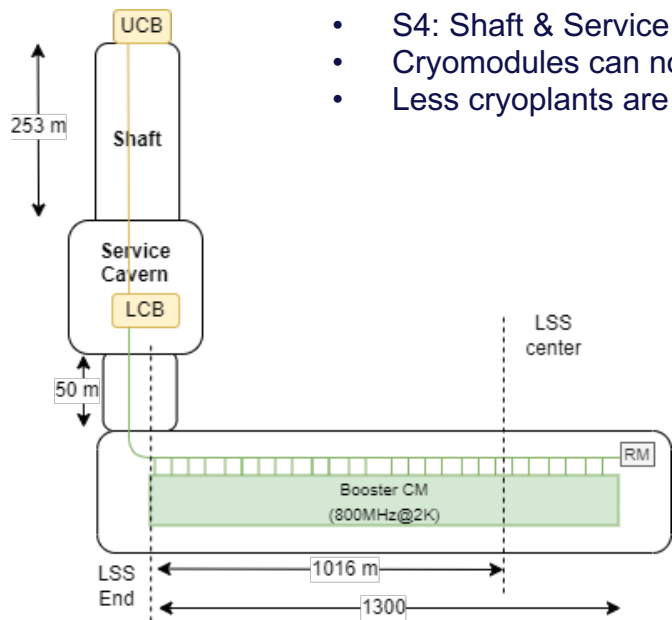

QRL Header	Diameter (mm)
	S4
A : 1.3 bar , 2.2 K ($\Delta P=25 \text{ mbar}$)	80
B : 30 mbar , 2 K ($\Delta P=2 \text{ mbar}$)	360
C : 3 bar, 4.6 K ($\Delta P=130 \text{ mbar}$)	-
D : 1.3 bar, 4.5 K ($\Delta P=70 \text{ mbar}$)	-
E : 20 bar, 50 K ($\Delta P=5 \text{ mbar}$)	90
F : 18 bar, 75 K ($\Delta P=10 \text{ mbar}$)	90
Vacuum jacket right	700*

* +100 mm for bellows and flanges