

TASCA separator – Trans Actinide Separator and Chemistry Apparatus



Task A: TASCA working group

Differential pumping and gas control

Main idea of work

- Windowless operation of separator

Main questions:

- * pressure – 0.3 – 2 mbar
 - * purity
 - * exhaust
 - * recycling
- * construction
 - * control

Separator TASCAs placement in the X8/X9 cave

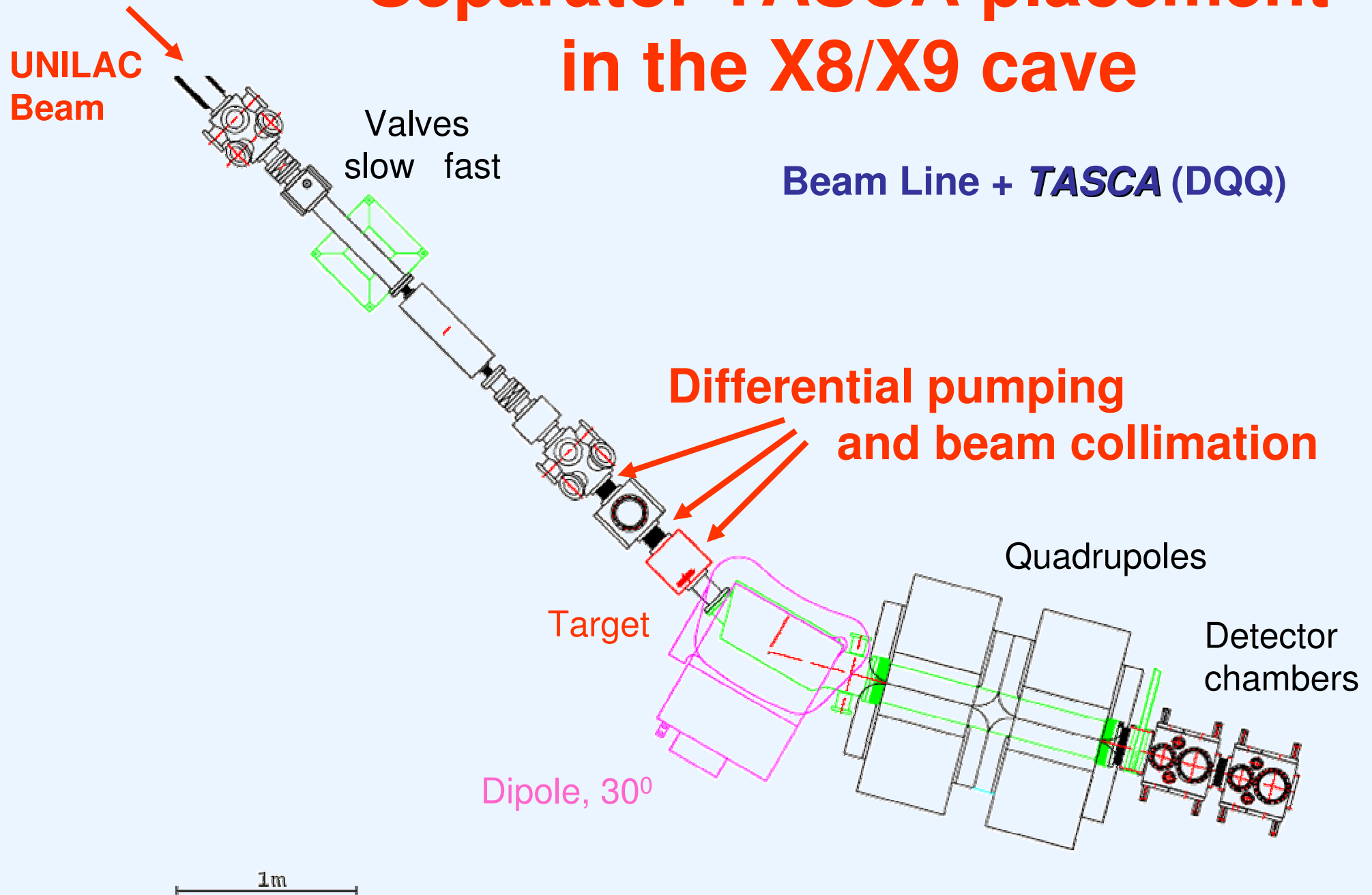

Drawings of Differential Pumping Part of TASCA gas-vacuum system

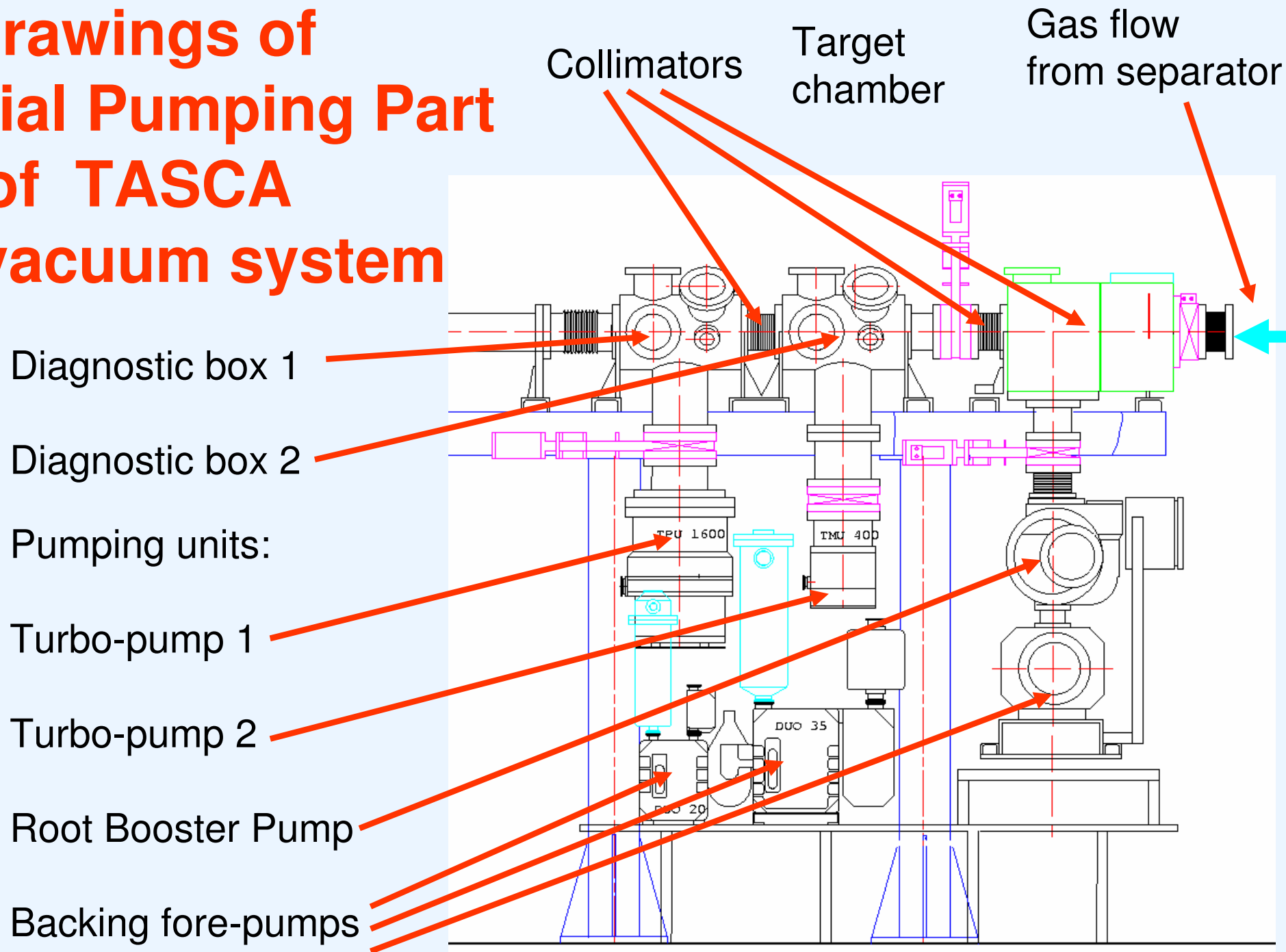

Structure scheme of TASCA gas-vacuum system

№2

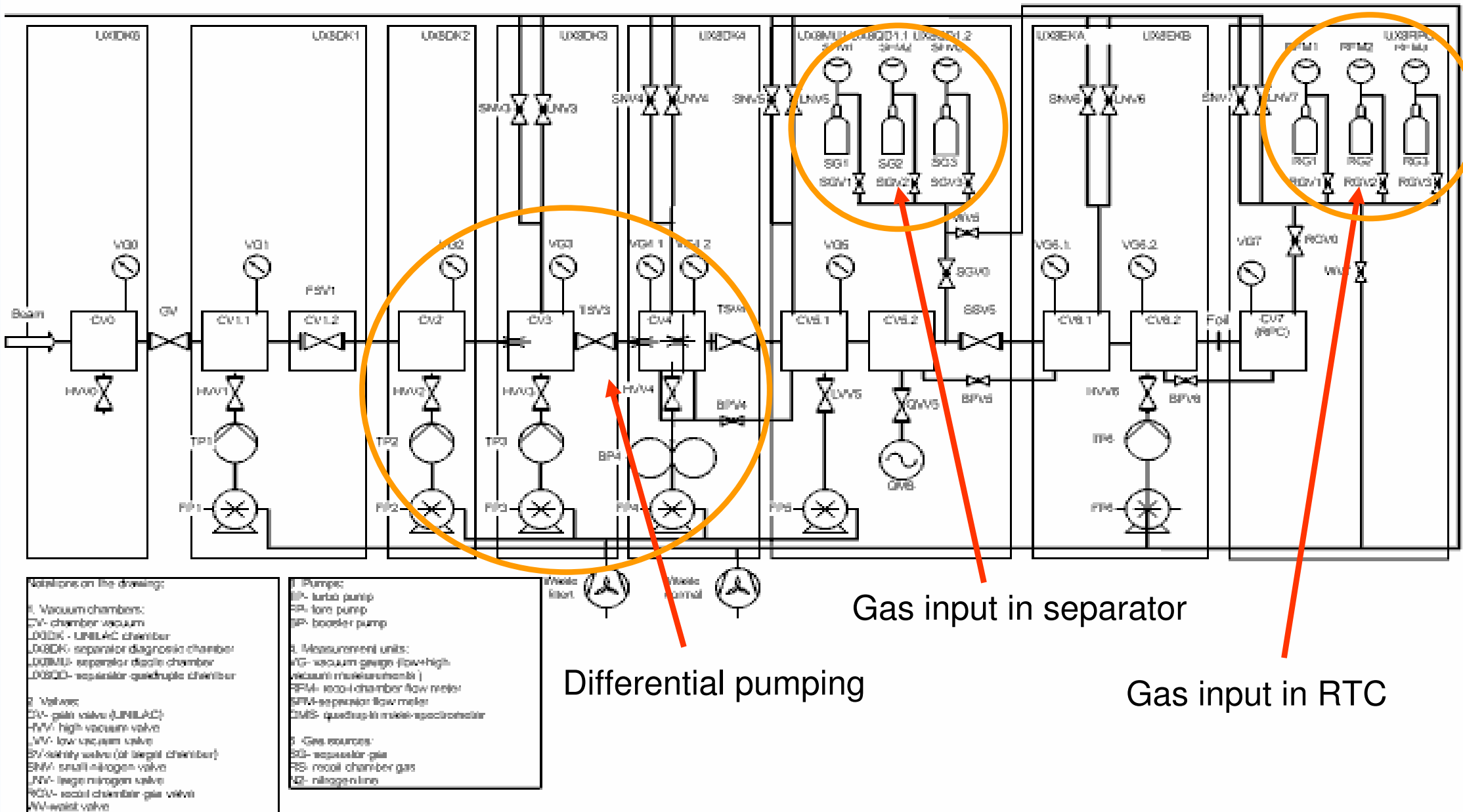

Gas input in separator

Differential pumping

Gas input in RTC

Structure of TASCA gas-vacuum system

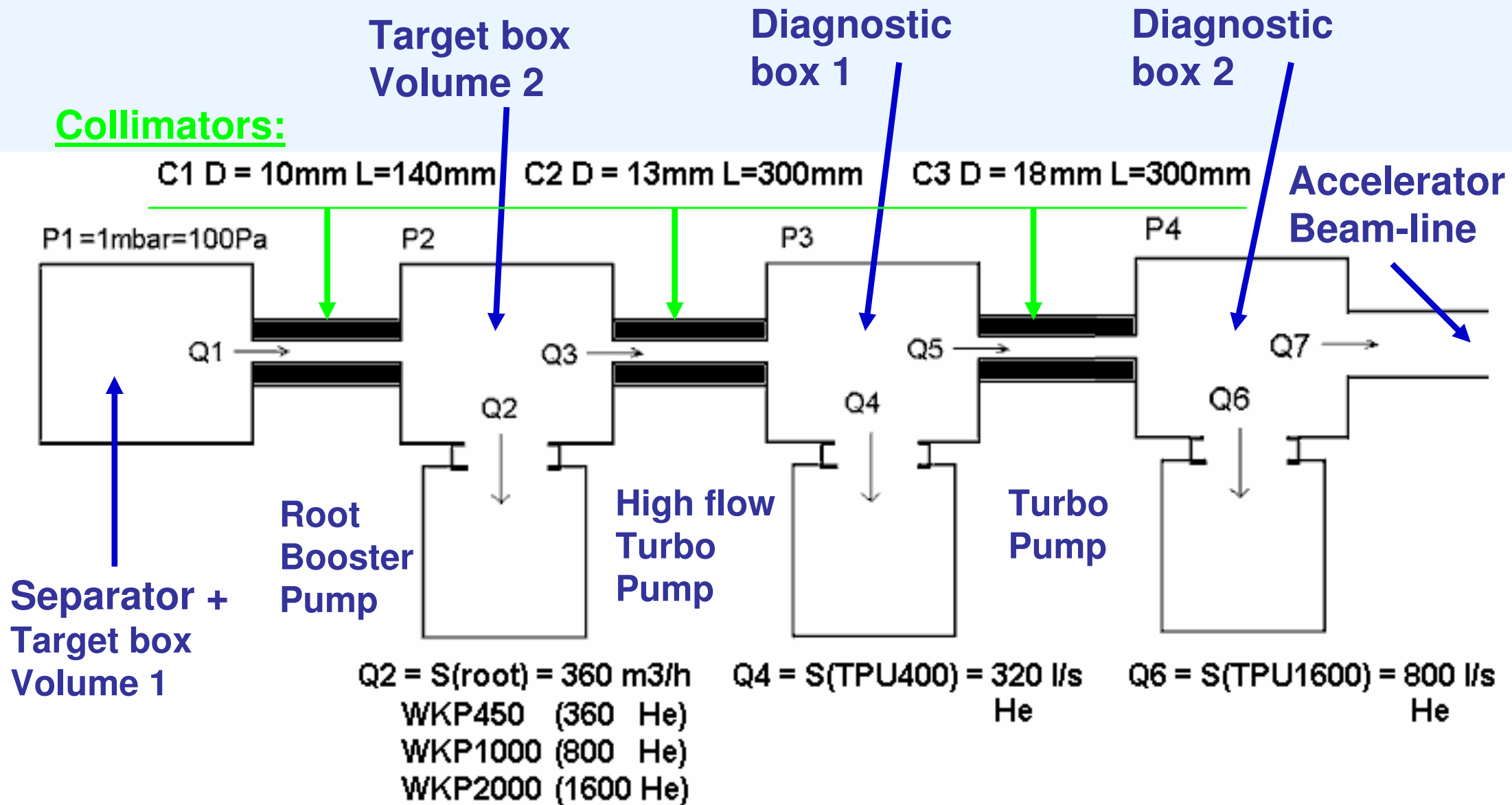

Programm for differential pumping system calculations

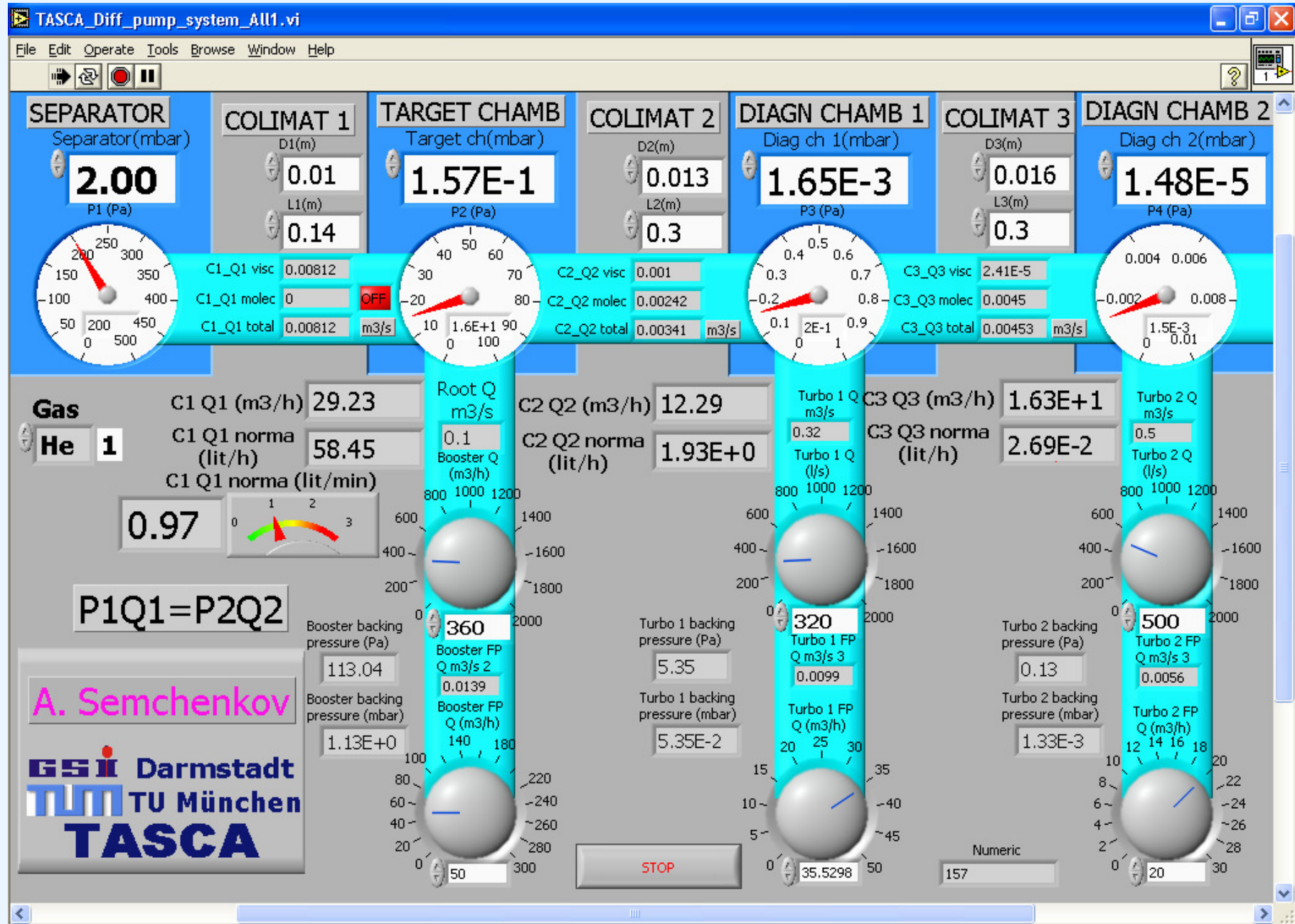

Equations used in calculations:

1. Viscous flow:

$$\underline{Q_v = \pi D^4 dP / 256 \eta L \text{ [m}^3/\text{s]},}$$

$\eta = 1.86 \cdot 10^{-5} \text{ [kg/(m*s)]}$ – viscosity of Helium at $t=20^\circ\text{C}$

D – diameter of collimator in m

L - length of collimator in m

P – pressure in Pa.

2. Molecular flow:

$$\underline{Q_m = (1/6) * (2\pi KT/m)^{1/2} * D^3 / L \text{ [m}^3/\text{s]},}$$

$K = 1.38 \cdot 10^{-23} \text{ J/K}$ - Boltzman constant

T – absolute temperature in K

D – diameter of collimator in m

L - length of collimator in m

Test of differential pumping system with He

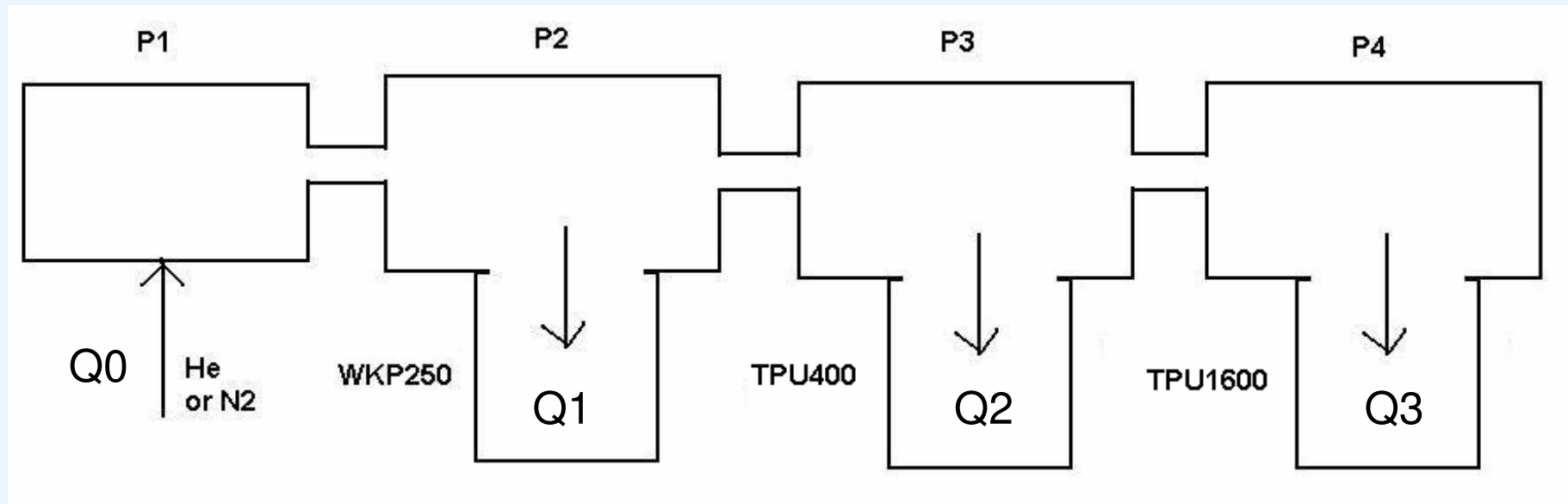

Q0 l/min		<u>P1</u> mbar	P2 mbar		P3 mbar		P4 mbar		Q1 m ³ /h	Q2 l/s	Q3 l/s
exper	calc		exper	calcul	exper	calcul	exper	calcul			
0.15	0.1	<u>0.62</u>	1.0*10 ⁻¹	<u>3.0*10⁻²</u>	<u>1.5*10⁻⁴</u>	<u>2.4*10⁻³</u>	<u>9.0*10⁻⁶</u>	<u>2.4*10⁻⁶</u>	200	320	460
0.41	0.32	<u>1.1</u>	1.9*10 ⁻¹	<u>1.0*10⁻¹</u>	<u>4.0*10⁻⁴</u>	<u>8.4*10⁻⁴</u>	<u>1.3*10⁻⁵</u>	<u>8.2*10⁻⁶</u>	200	320	460
0.87	1.00	<u>2</u>	5.0*10 ⁻¹	<u>2.8*10⁻¹</u>	<u>8.7*10⁻³</u>	<u>3.6*10⁻³</u>	<u>1.5*10⁻⁵</u>	<u>3.5*10⁻⁵</u>	200	320	460
0.15	0.09	<u>0.62</u>	1.0*10 ⁻¹	1.0*10 ⁻¹	1.5*10 ⁻⁴	1.0*10 ⁻⁴	9.0*10 ⁻⁶	1.0*10 ⁻⁵	<u>45</u>		
0.41	0.3	<u>1.1</u>	1.9*10 ⁻¹	1.9*10 ⁻¹	4.0*10 ⁻³	1.4*10 ⁻³	1.3*10 ⁻⁵	2.0*10 ⁻⁵	<u>80</u>		
0.87	0.85	<u>2</u>	5.0*10 ⁻¹	5.0*10 ⁻¹	8.7*10 ⁻³	9.0*10 ⁻³	1.5*10 ⁻⁴	1.0*10 ⁻⁴	<u>80</u>		

Test of differential pumping system with He and N2

$$S(\text{doc}) = Q1 = 250 - N2$$

$$200 - \text{He} - 80\%$$

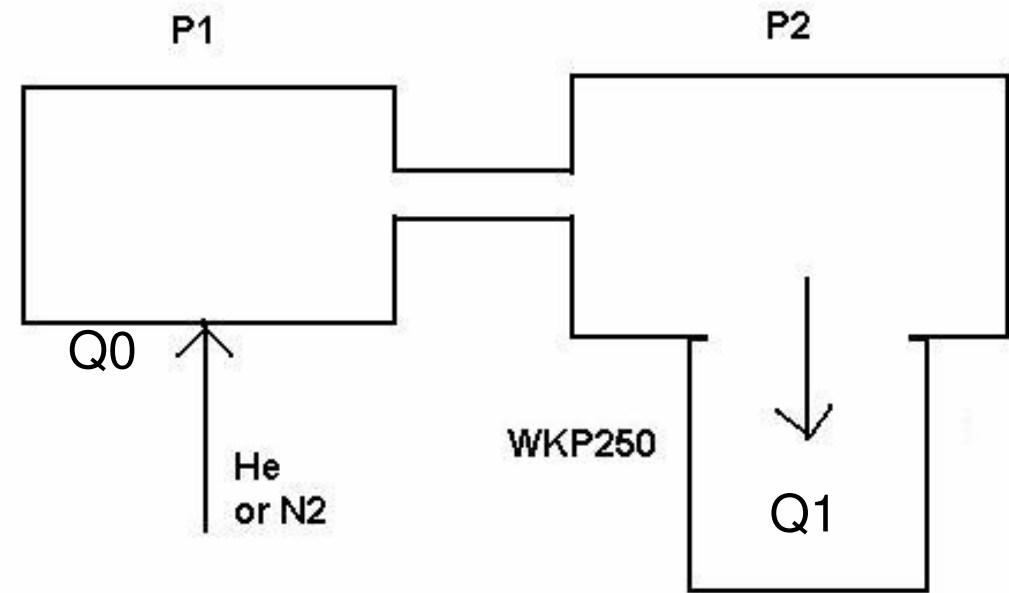

Q1(He) l/min		<u>P1</u>	P2 mbar		Q1 m3/h	Q0(N ₂) l/min		<u>P1</u>	P2 mbar	
exper	calc	<u>mbar</u>	exper	calcul	calc	exper	calcul	mbar	exper	calcul
0.38	0.25	<u>1</u>	2.*10 ⁻¹	7.5*10 ⁻²	70	0.23	0.26	1	9.1*10 ⁻²	6.2*10 ⁻²
0.93	0.9	<u>2</u>	5.*10 ⁻¹	2.7*10 ⁻¹	100	0.67	1.1	2.1	2.2*10 ⁻¹	2.6*10 ⁻²
1.89	2.5	<u>3.5</u>	1.	7.7*10 ⁻¹	150	2.09	3.5	4	5.8*10 ⁻¹	8.3*10 ⁻¹
	<u>plus</u>	<u>oil</u>	<u>pump:</u>							
0.35	0.25	<u>1</u>	1.3*10 ⁻¹	7.5*10 ⁻²	100					
0.97	0.9	<u>2</u>	2.7*10 ⁻¹	2.7*10 ⁻¹	200					

Main questions in differential pumping system with He

1. Maximum pressure in the target chamber

- 0.3 – 2 mbar ???

2. Capacity of pumping of ROOT Booster Pump:

WKP 500

WKP1000

WKP2000

3. Dry or Oil pump, as a backing pump