

Cold Highly Charged Ions in a Cryogenic Paul Trap

O. O. Versolato · M. Schwarz ·
A. Windberger · J. Ullrich ·
P. O. Schmidt · M. Drewsen ·
J. R. Crespo López-Urrutia

Received: date / Accepted: date

Abstract Narrow optical transitions in highly charged ions (HCIs) are of particular interest for metrology and fundamental physics, exploiting the high sensitivity of HCIs to new physics. The highest sensitivity for a changing fine structure constant ever predicted for a stable atomic system is found in Ir^{17+} . However, laser spectroscopy of HCIs is hindered by the large ($\sim 10^6$ K) temperatures at which they are produced and trapped. An unprecedented improvement in such laser spectroscopy can be obtained when HCIs are cooled down to the mK range in a linear Paul trap. We have developed a cryogenic linear Paul trap in which HCIs will be sympathetically cooled by $^9\text{Be}^+$ ions. Optimized optical access for laser light is provided while maintaining excellent UHV conditions. The Paul trap will be connected to an electron beam ion trap (EBIT) which is able to produce a wide range of HCIs. This EBIT will also provide the first experimental input needed for the determination of the transition energies in Ir^{17+} , enabling further laser-spectroscopic investigations of this promising HCI.

O. O. Versolato
Max-Planck-Institut für Kernphysik, D-69116 Heidelberg
Tel.: +49-6221-516-331
Fax: +49-6221-516-601
E-mail: oscar.versolato@mpi-hd.mpg.de

M. Schwarz, A. Windberger, and J. R. Crespo López-Urrutia
Max-Planck-Institut für Kernphysik, D-69116 Heidelberg

J. Ullrich
Physikalisch-Technische Bundesanstalt, Bundesallee 100, D-38116, Braunschweig
Max-Planck-Institut für Kernphysik, D-69116 Heidelberg

P. O. Schmidt
Institut für Quantenoptik, Leibniz Universität Hannover, D-30167 Hannover
Physikalisch-Technische Bundesanstalt, Bundesallee 100, D-38116, Braunschweig

M. Drewsen
Department of Physics and Astronomy, University of Aarhus, DK-8000 Aarhus C

Keywords Highly Charged Ions · EBIT · cryogenic Paul trap · alpha time variation

1 Introduction

Highly charged ions provide a wealth of physics spanning the range from optical atomic clocks, via QED tests, to astrophysics. Several rule-of-thumb scaling laws illustrate the physics potential of HCIs: the binding energy of the valence electron scales as Z^2 (where Z is the charge state); electron density at the nucleus as Z^3 ; and atomic parity violation as Z^5 . HCIs are also sensitive probes to test possible time variation of the fine structure constant α (ATV for alpha time variation). Here, high sensitivity is obtained due to the high nuclear charge Z_n ($\sim Z_n^2$), high ionization potential ($\sim Z_{\text{eff}}^2$ with effective charge Z_{eff} [1]), and the large possible differences in configuration composition [2,3]. Scaling may even be faster in certain hole transitions [3]. The transitions involved, however, need to be accessible by modern lasers to enable high-accuracy laser spectroscopy. Certain electron shells cross along isoelectronic sequences. Optical transitions may be available at, or near, such level crossings. This concept provides a tool for theorists to search for transitions in the optical domain. Many such transitions with advantageous properties have been found by these means [1]. In particular, certain transitions Ir^{17+} are found to have the largest sensitivity to ATV ever predicted in a stable atomic system [3]. However, a relatively large theoretical uncertainty in the energy differences (related to near-cancellations of term energies) between states make direct laser spectroscopy impractical at this time. First, a better understanding of the level structure needs to be obtained. Such understanding can be attained by means of electron impact spectroscopy in an electron beam ion trap (EBIT) available at the Max-Planck-Institut für Kernphysik (MPIK). Spectroscopy of the fluorescent light emitted by the electron-impact excited ions can yield sub-ppm accuracy for the absolute determination of transition wavelengths [4,5]. After such preliminary work we propose to exploit this system for a competitive search for ATV by performing laser spectroscopy of laser-cooled Ir^{17+} trapped in a cryogenic Paul trap that was newly constructed for the purpose of trapping HCIs. Quantum logical readout will be applied for ultimate sensitivity [6]. This project is a collaboration between MPIK, Aarhus University (AU), and the Physikalisch-Technische Bundesanstalt (PTB) in Braunschweig, Germany.

2 Cryogenic Paul trap for HCIs

Single particles can be laser cooled to the zero point of their motion when trapped. This reduces Doppler broadening to negligible levels. Spectroscopy of HCIs will greatly improved when these ions can be cooled down to such mK levels from the MK temperatures at which they are typically produced [7]. As

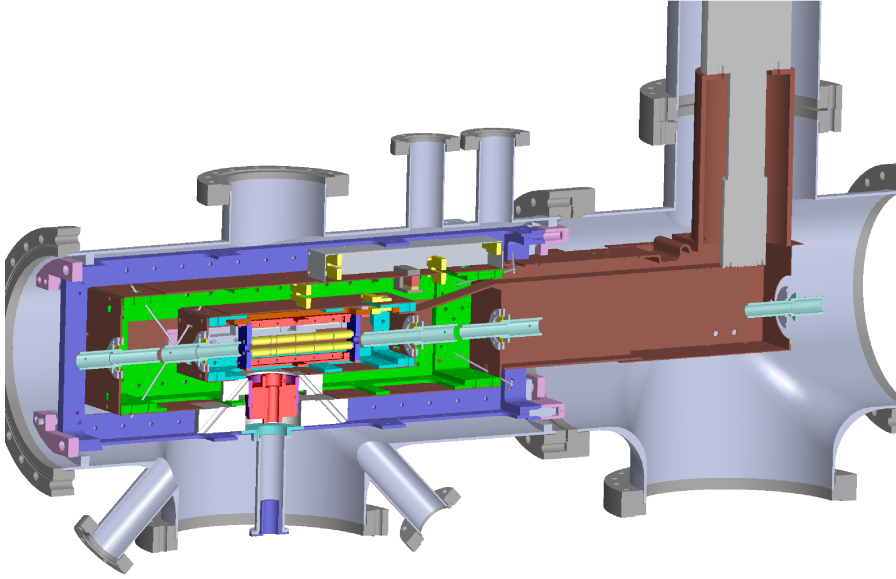

Fig. 1 Vertical cross-section along the main axis of the cryogenic Paul trap CryPTEx. Depicted are: cryogenic shielding (brown), stainless steel frames (navy blue, green), trap electrodes (yellow), ion optics (grey tubes), and the vacuum chamber (grey).

not all HCIs are amenable to direct laser cooling, sympathetic cooling is envisaged using co-trapped laser-cooled ions. Such cooling of HCIs led to the first (and only) sympathetic cooling of the HCI Xe^{34+} by ${}^9\text{Be}^+$ ions at RETRAP [8,9]. A similar cooling scheme is envisaged for its successor SPECTRAP at the Gesellschaft für Schwerionenforschung (GSI) where laser cooled Mg^+ ions will be used to provide cooling force [10] among other cooling schemes. Other proposals include refs. [11,12]. The aforementioned experiments and proposals are all based on Penning traps, which are particularly suited for storing HCIs. However, laser-spectroscopic accuracy suffers from field noise in these magnetic traps. The electrodynamic Paul traps [13,14] have found widespread applications in the field of atomic and molecular physics [15,16], quantum computing [17–19], and frequency metrology [20,21]; Paul traps are the current-day working horse for precision laser spectroscopy. Single ions trapped in Paul traps nowadays provide the most accurate frequency standards with relative accuracies below 10^{-17} [22]. For these purposes we have designed and constructed CryPTEx (Cryogenic Paul Trap Experiment) at MPIK in collaboration with the Ion Trap Group at AU. This cryogenically cooled linear Paul trap has multiple optical access points, provides connectivity to external ion beam sources, and exhibits excellent mechanical, electrical, and thermal stability (see Fig.1). The cryogenic environment enables ultra-high vacuum (UHV) conditions [23]. Charge exchange presents a limit to the trapping time of HCIs. Therefore,

ultra-high vacuum conditions are a prerequisite for storing HCIs in a Paul trap. The apparatus employs a pulse-tube cryocooler, provides optical access, and has ion injection capabilities that are indispensable for HCI related work. CryPTEx has been commissioned at AU using Mg^+ and MgH^+ ions [24], continuing the work of preparing cold samples of these molecular ions [25,26]. Excellent performance of the trap was established. Experiments are in progress that particularly exploit the low exposure to black-body radiation inherent to our cryogenic design [27,28]. The trap will be transported back to the MPIK after completion of these measurements. It will then be connected to an EBIT which will provide the HCIs of interest. These HCIs will be laser cooled employing $^9\text{Be}^+$ ions as sympathetic coolants. Laser systems for Doppler cooling and photo-ionization are being set up [24].

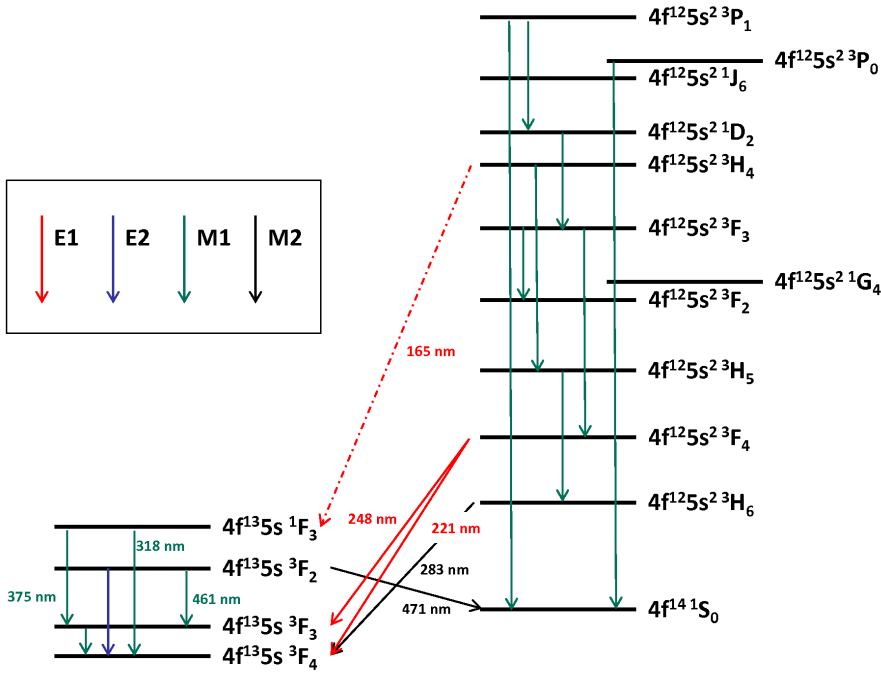

Fig. 2 Partial level scheme and transitions wavelengths in Ir^{17+} based on ref.[3]. Energy positions are not drawn to scale.

3 Electron Impact Spectroscopy in an EBIT

The black lines in Fig. 2 depict strongly forbidden transitions in Ir^{17+} with high sensitivity to ATV. A comparison of the transition energies of the $4f^{13}5s\ ^3F_4$ to $4f^{12}5s^2\ ^3H_6$ transition at 283 nm and the $4f^{14}\ ^1S_0$ to $4f^{13}5s\ ^3F_2$ transition at 471 nm wavelength yield a total sensitivity to ATV that is about 13 times more sensitive than the Hg^+ - Al^+ clock comparison that sets the current-day best limit on ATV [21]. However, the theoretical uncertainties for the Ir^{17+} energy levels are at the 6000 cm^{-1} level (although fine structure splitting within terms is more accurate) [3]. This implies an uncertainty of about 25 nm for the E2 transition at 283 nm. This rather large uncertainty presents an experimental inconvenience for laser spectroscopy, particularly in the case of a long-lived metastable state like $4f^{12}5s^2\ ^3H_6$. First, a more accurate determination of the transition energies is required. One of the advantageous properties of EBITs is that there is a high electronic excitation rate of the trapped ions by means of electron impact. Near the ionization energy of Ir^{16+} at 410 eV the electrons have more than sufficient energy to excite the relevant levels. The subsequent fluorescent decay of the ions can be observed employing a cryogenic charge-coupled device (CCD) with 2000×800 pixels on a $30 \times 12\text{ mm}^2$ chip. A Czerny-Turner (JY TRIAX 550) interferometer provides wavelength information at high resolving power. Previous such measurements provided the determination of the line center of the $^2P_{1/2} - ^2P_{3/2}$ transition in Ar^{13+} at 441 nm wavelength at sub-ppm accuracy [5]. It is our aim to obtain similar accuracies on the M1 and E1 lines of Ir^{17+} (see Fig.2) in the optical regime between 200 nm and 700 nm. Reference lines for calibration purposes are provided by hollow-cathode lamps. The E1 lines near 221 nm and 248 nm (red lines in Fig. 2) which connect the two configuration compositions are of particular interest. The radiative life time of these electronically excited states can also be extracted, yielding important information on (dipole) matrix elements.

4 Outlook

Our cryogenic Paul trap is now being connected to an EBIT and is expected to be loaded with HCIs in the coming months. Laser systems for high-precision spectroscopy of HCIs as well as for the creation $^9\text{Be}^+$ ions by means of photo-ionization are being set up. A high power laser system for the laser-cooling of $^9\text{Be}^+$ ions is already available at MPIK. EBIT measurements will soon provide the first input needed for a necessary experimental determination of the transition energies of Ir^{17+} at a level required for laser experiments. Laser spectroscopy of trapped and sympathetically cooled Ir^{17+} could possibly yield final fractional uncertainties below 10^{-18} which, together with its high sensitivity to ATV, would lead to a two-orders-of-magnitude improvement over the current limit on ATV [21].

References

1. J.C. Berengut, V.A. Dzuba, V.V. Flambaum, A. Ong, arXiv:1206.0534v1 [physics.atom-ph] (2012)
2. J.C. Berengut, V.A. Dzuba, V.V. Flambaum, Phys. Rev. Lett. **105**, 120801 (2010)
3. J.C. Berengut, V.A. Dzuba, V.V. Flambaum, A. Ong, Phys. Rev. Lett. **106**, 210802 (2011)
4. I. Draganić, J.R. Crespo López-Urrutia, R. DuBois, S. Fritzsche, V.M. Shabaev, R.S. Orts, I.I. Tupitsyn, Y. Zou, J. Ullrich, Phys. Rev. Lett. **91**, 183001 (2003)
5. R.S. Orts, Z. Harman, J.R.C. López-Urrutia, A.N. Artemyev, H. Bruhns, A.J.G. Martínez, U.D. Jentschura, C.H. Keitel, A. Lapierre, V. Mironov, V.M. Shabaev, H. Tawara, I.I. Tupitsyn, J. Ullrich, A.V. Volotka, Phys. Rev. Lett. **97**, 103002 (2006)
6. P.O. Schmidt, T. Rosenband, C. Langer, W.M. Itano, J.C. Bergquist, D.J. Wineland, Science **309**(5735), 749 (2005)
7. V. Mäckel, R. Klawitter, G. Brenner, J.R. Crespo López-Urrutia, J. Ullrich, Phys. Rev. Lett. **107**, 143002 (2011)
8. L. Gruber, J.P. Holder, J. Steiger, B.R. Beck, H.E. DeWitt, J. Glassman, J.W. McDonald, D.A. Church, D. Schneider, Phys. Rev. Lett. **86**, 636 (2001)
9. L. Gruber, J.P. Holder, D. Schneider, Physica Scripta **71**(1), 60 (2005)
10. R. Cazan, C. Geppert, W. Nörtershäuser, R. Sanchez, Hyperfine Interactions **196**, 177 (2010)
11. M. Bussmann, U. Schramm, D. Habs, V. Kolhinen, J. Szerypo, International Journal of Mass Spectrometry **251**(23), 179 (2006)
12. M. Bussmann, U. Schramm, D. Habs, Hyperfine Interactions **173**, 27 (2006)
13. W. Paul, Rev. Mod. Phys. **62**, 531 (1990)
14. G. Werth, Lect. Notes Physics **749**, 31 (2008)
15. S. Willitsch, M.T. Bell, A.D. Gingell, T.P. Softley, Phys. Chem. Chem. Phys. **10**, 7200 (2008)
16. F. Major, V. Gheorghe, G. Werth, *Charged Particle Traps II* (Springer, 2009)
17. D. Leibfried, R. Blatt, C. Monroe, D. Wineland, Rev. Mod. Phys. **75**, 281 (2003)
18. H. H Physics Reports **469**(4), 155 (2008)
19. R. Blatt, D. Wineland, Nature **453** (2008)
20. P. Gill, Philos. T. R. Soc. A **369**, 4109 (2011)
21. T. Rosenband, D.B. Hume, P.O. Schmidt, C.W. Chou, A. Brusch, L. Lorini, W.H. Oskay, R.E. Drullinger, T.M. Fortier, J.E. Stalnaker, S.A. Diddams, W.C. Swann, N.R. Newbury, W.M. Itano, D.J. Wineland, J.C. Bergquist, Science **319**, 1808 (2008)
22. C.W. Chou, D.B. Hume, J.C.J. Koelemeij, D.J. Wineland, T. Rosenband, Phys. Rev. Lett. **104**, 070802 (2010)
23. C. Benvenuti, Journal of Vacuum Science and Technology **11**(3), 591 (1974)
24. M. Schwarz, O.O. Versolato, A. Windberger, F.R. Brunner, T. Ballance, S.N. Eberle, J. Ullrich, P.O. Schmidt, A.K. Hansen, A.D. Gingell, M. Drewsen, J.R. Crespo Lopez-Urrutia, Review of Scientific Instruments **83**(8), 083115 (2012)
25. K. Mølhave, M. Drewsen, Phys. Rev. A **62**, 011401 (2000)
26. P.F. Staunum, K. Højbjerg, P.S. Skyt, A.K. Hansen, M. Drewsen, Nature Physics **6**, 271 (2010)
27. M. Schwarz et al., in preparation (2012)
28. A.D. Gingell et al., in preparation (2012)