

Coil and Cryostat Interfaces and Time Scale

Andrea Bersani
INFN Sezione di Genova

Yoke to Cryostat Interface

- ⌋ We have an old design (2008)
- ⌋ It's based on 16 supports placed on the two ends of the cryostat, at the corners of the yoke
- ⌋ The cryostat is inserted in the yoke and then bolted to it via these supports
- ⌋ Between the end of 2008 and the beginning of 2009 some calculations were performed and this solution resulted viable
- ⌋ Disadvantages:
 - ⌋ too many points
 - ⌋ need for in loco positioning

Yoke to Cryostat Interface

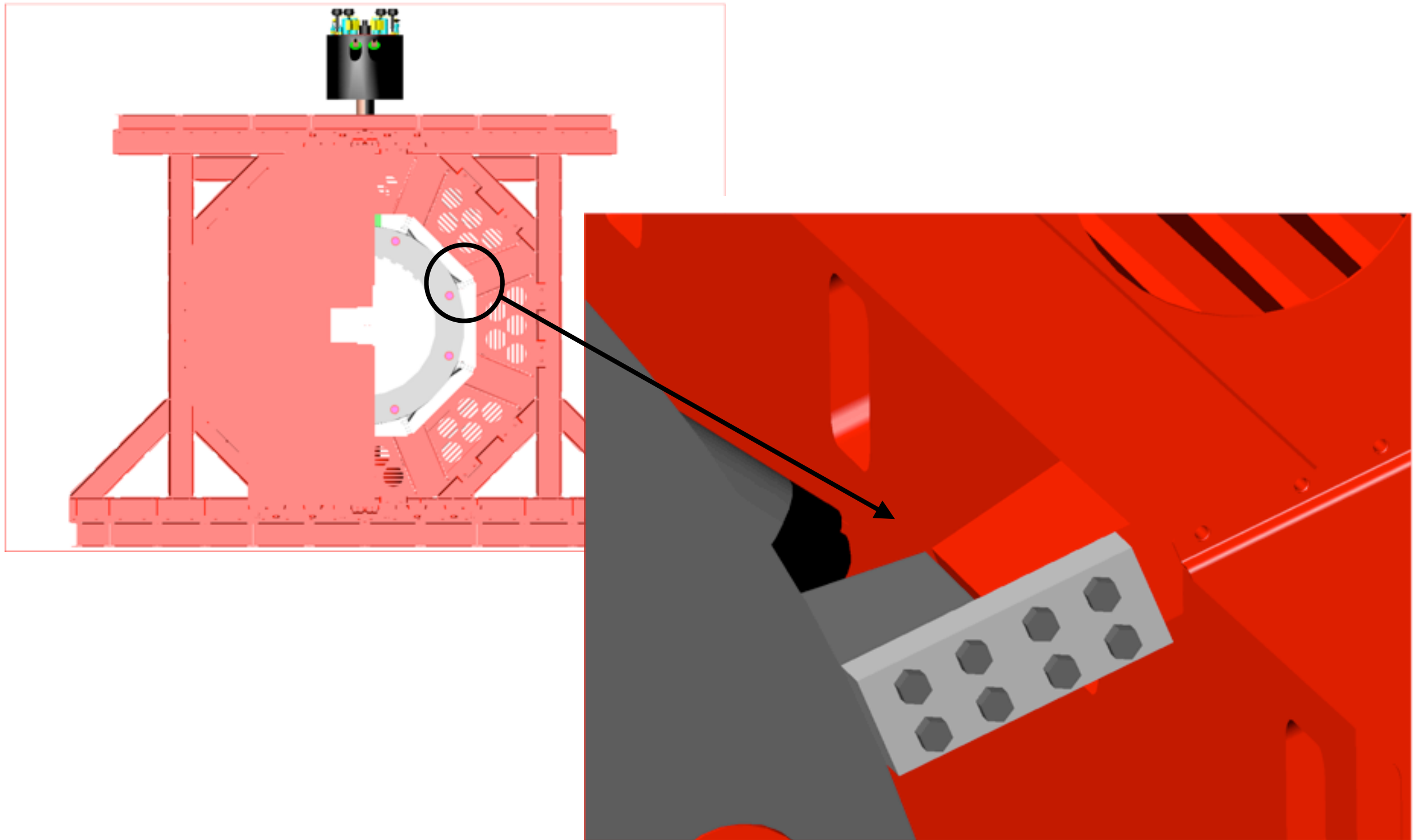

Yoke to Cryostat Interface

- ⌋ Requirements for any new solution
 - ⌋ the same mechanical stability as this one
 - ⌋ attachment points must be in the same region
 - ⌋ minimal interference with the muon chambers

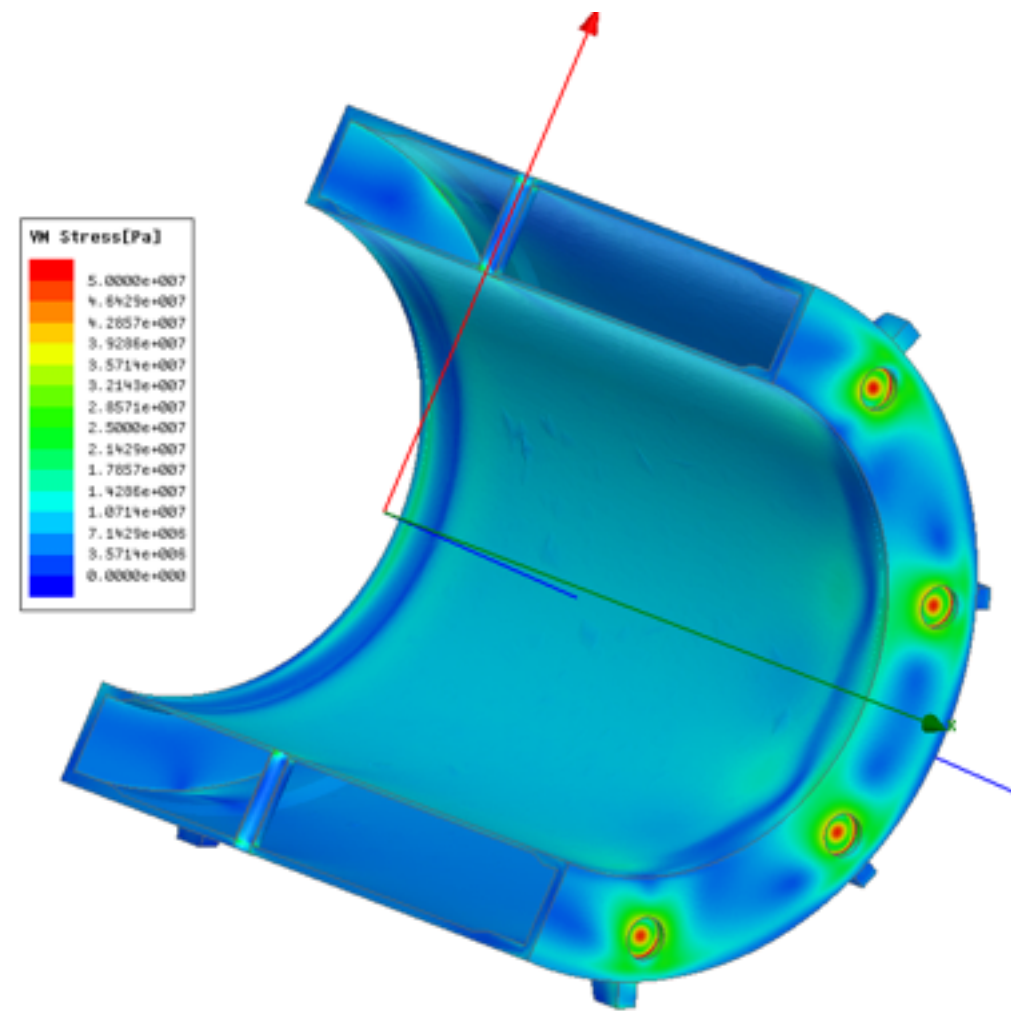
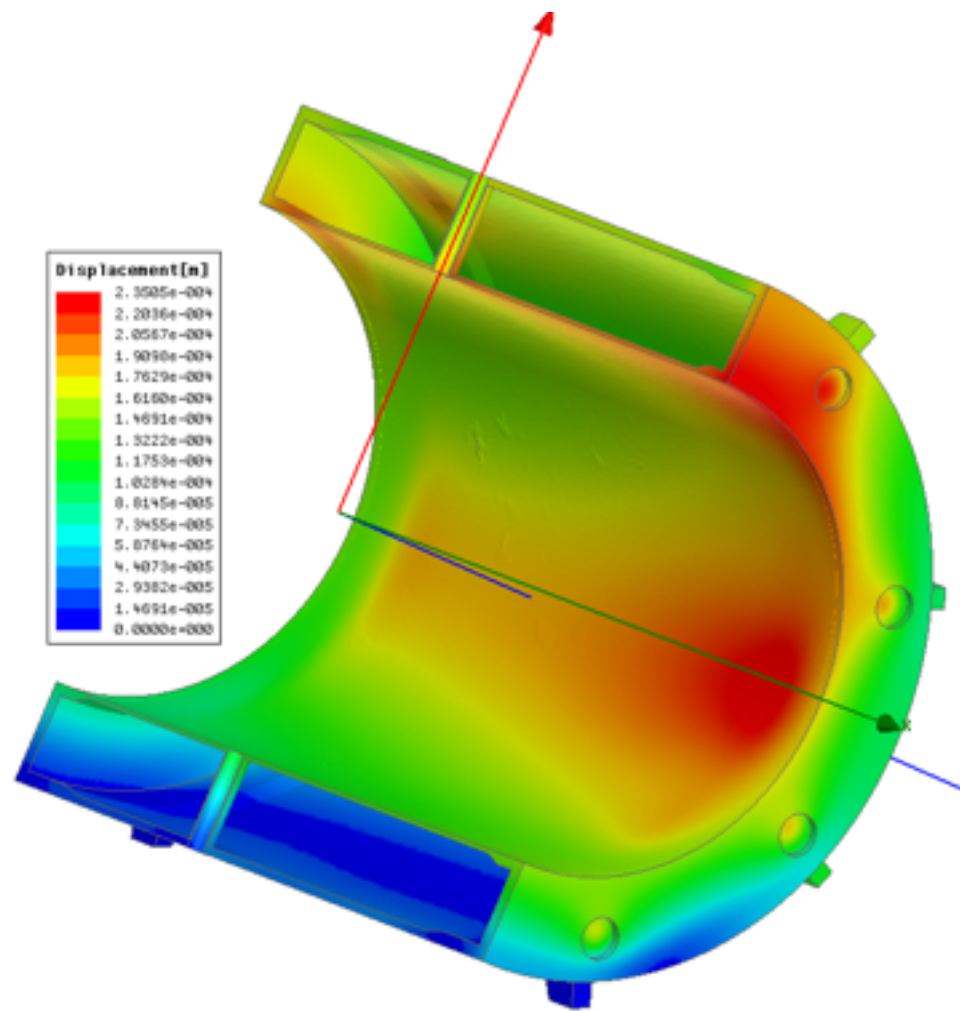

Yoke to Cryostat Interface

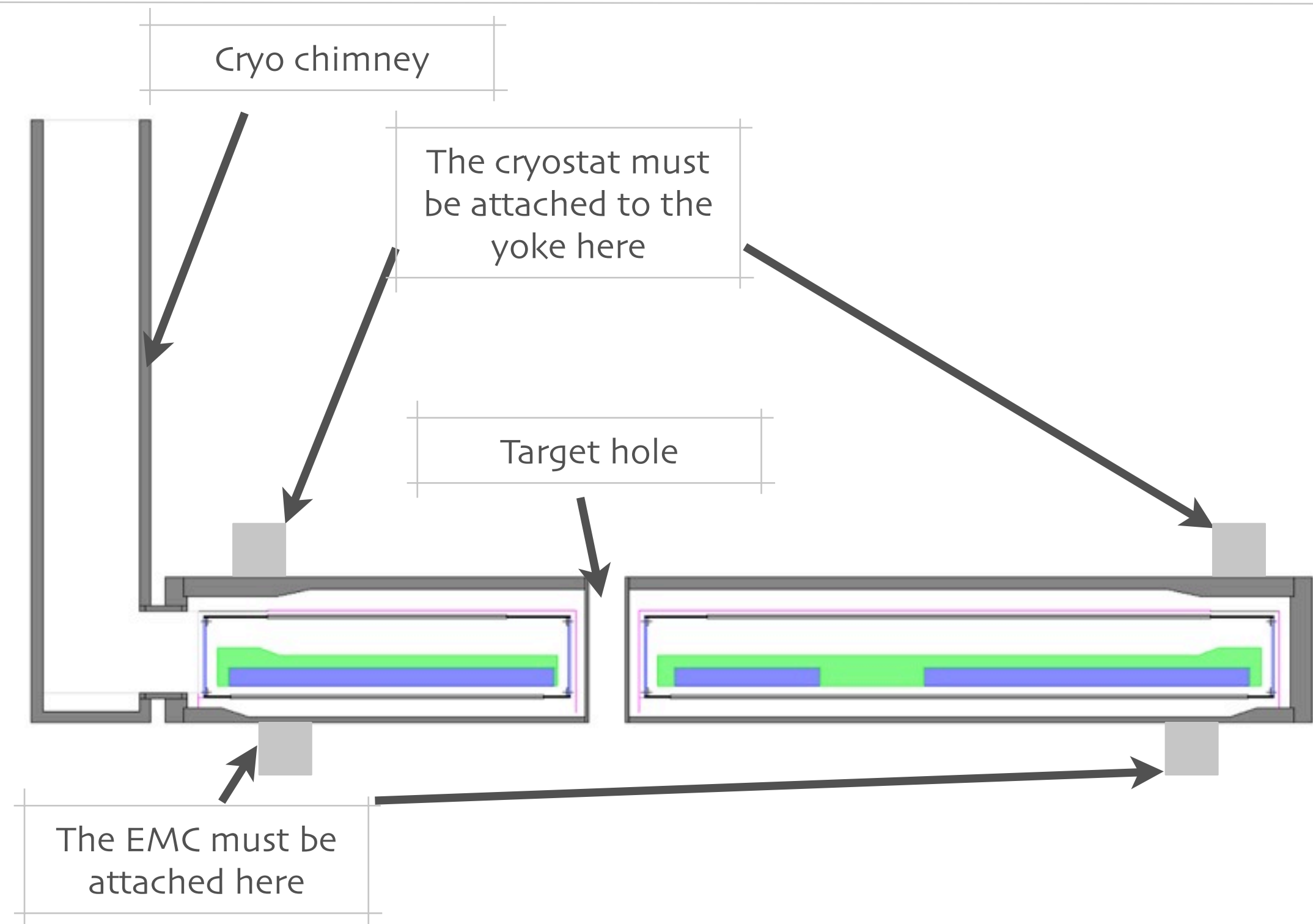

Up to the Wildest Ideas

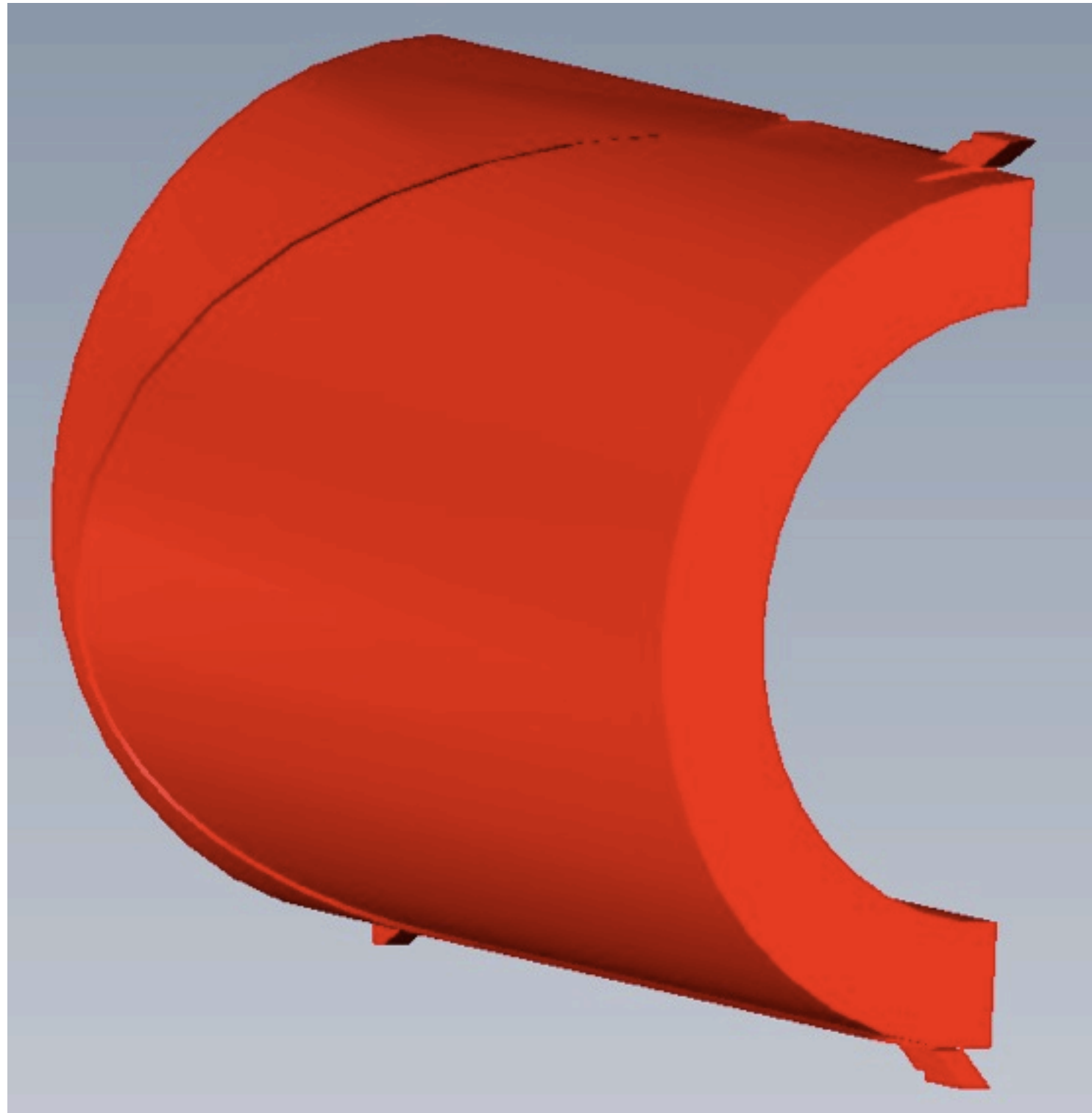

Time Scale for the Coil&Cryostat

- Expected PANDA Hall delivery date: April the 1st, 2017
- Preliminary setup at FZJ: 2 years for commissioning, field mapping, target and detectors integration
- Construction: 3 years
- We should be ready to go for a tender "not too late" in 2011

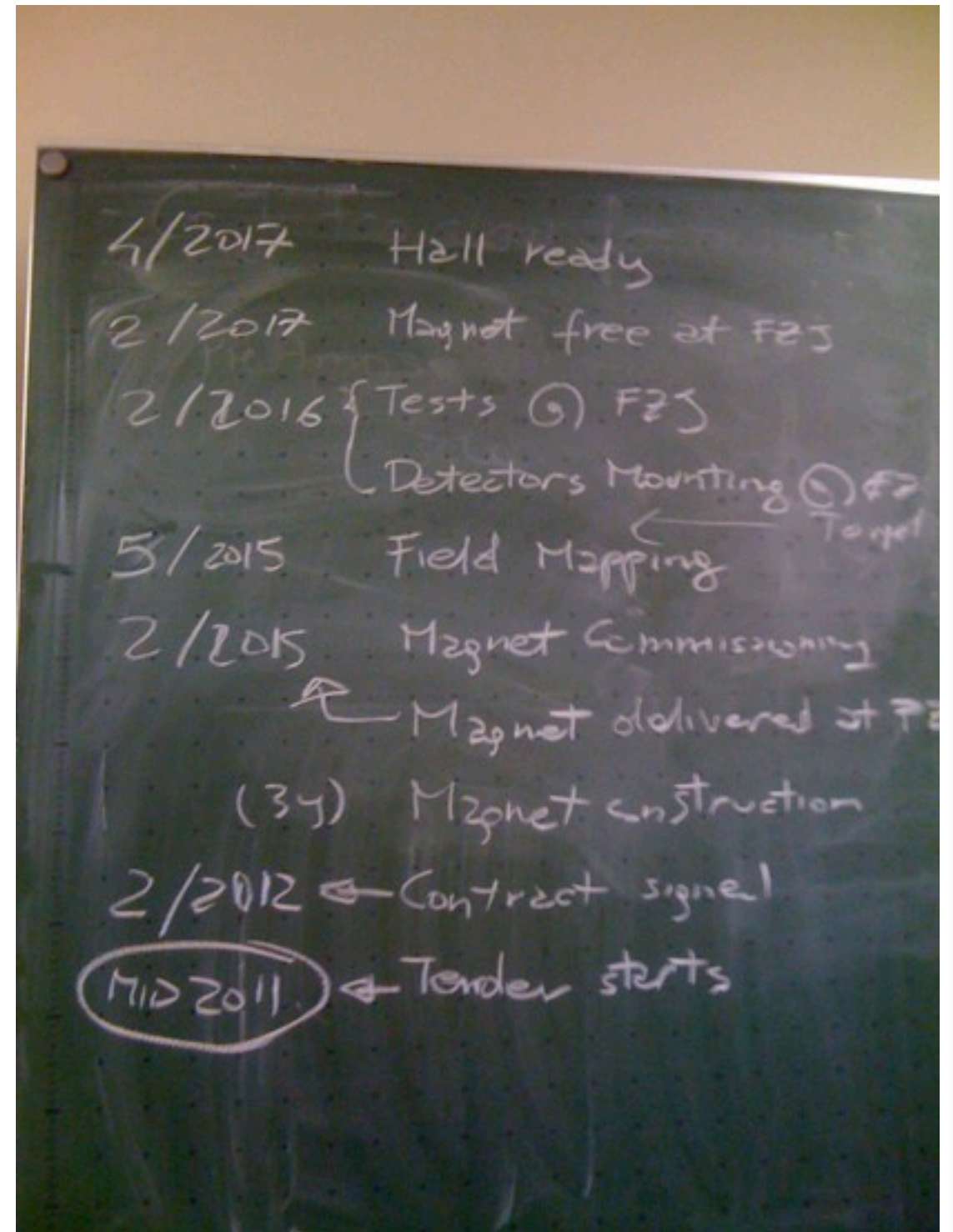

What Do We Need for a Tender?

- A clear idea of what we want
 - we have the TDR, it should be sufficient
- A technical specification
 - we have a draft

Appendix C

Technical Specification for the PANDA TS Solenoid Magnet

COMMENT by Andre: VERY preliminary.

C.1 Introduction

C.1.1 Definitions

This document defines the specifications of the PANDA superconducting solenoid and ancillary systems (In the following, simply "the Solenoid").

This document was approved by PANDA Collaboration, which represents the final customer of the Solenoid. PANDA Collaboration will nominate a Committee which will supervise the project, the manufacturing, the installation and the tests of the Solenoid. This Committee will be the only recognised authority for authorisations and approvals required in the present document. In the following of this document, to the Committee, which represents PANDA Collaboration, will be referred simply as "the Customer".

- An agreed interface document
 - we have a partial one, not updated since a while
- A reasonable amount of money
 - we miss this