

# Cryostat design

## Thermosyphon cooling

Alexey Bragin, Vassily Syrovatin

Budker Institute of Nuclear Physics, Novosibirsk, Russia

November 2019

# Total view of the cryostat

The cryostat consists of three parts for assembling and to GSI transportation:

- The cryostat top unit
- The upper coil
- The lower coil.

The T-shape assembling place is a weldable part.

The helium tubes will be welded.

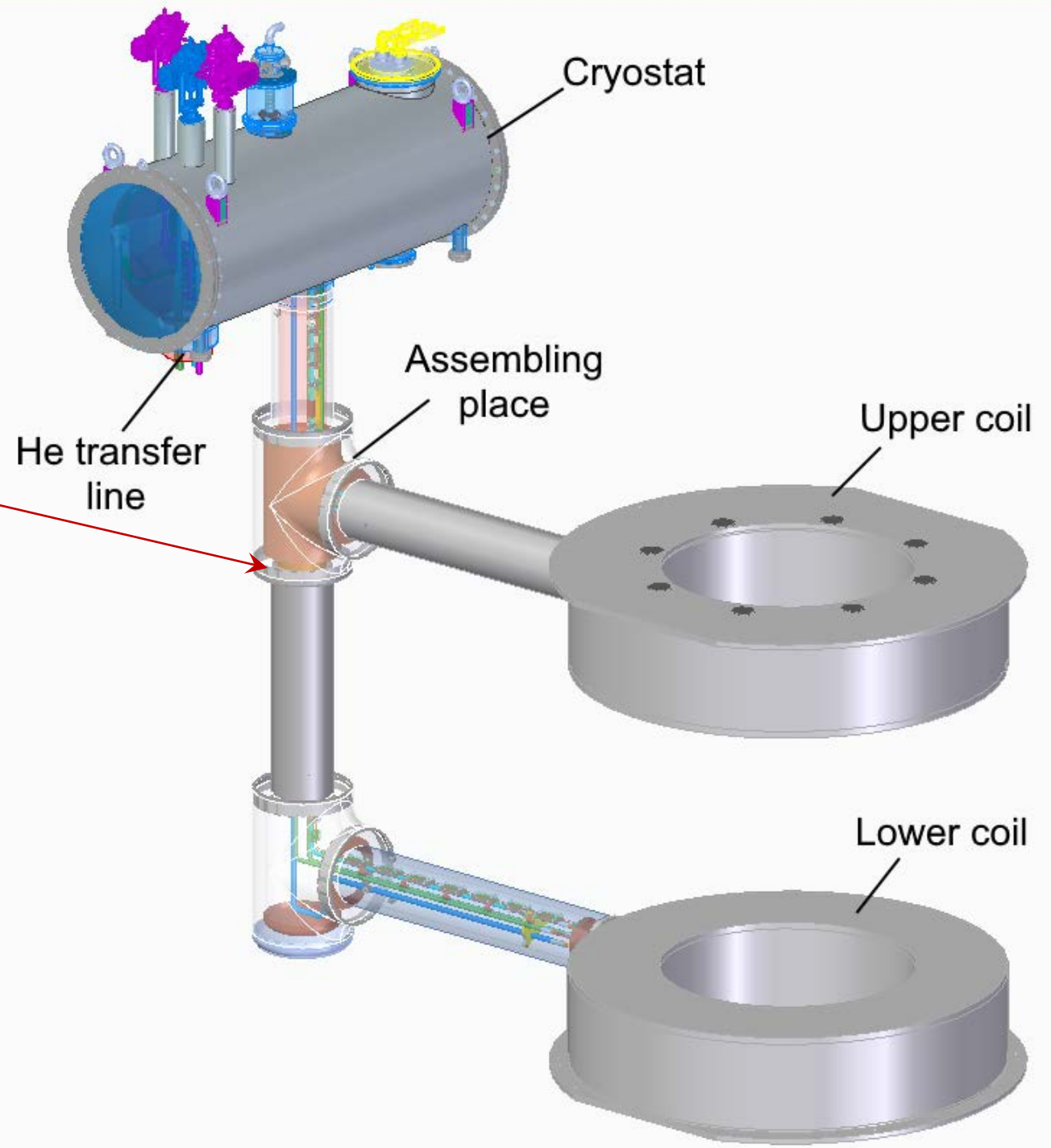

# Assembling parts of the cryostat

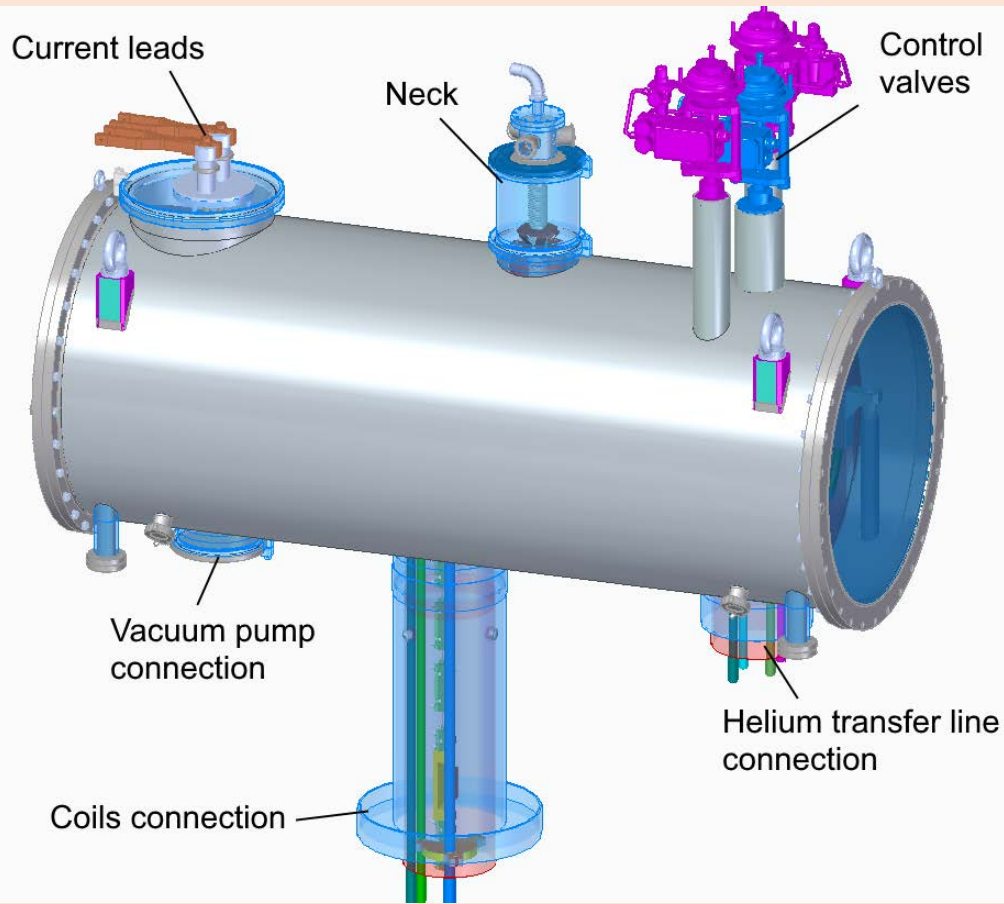

**cryostat**

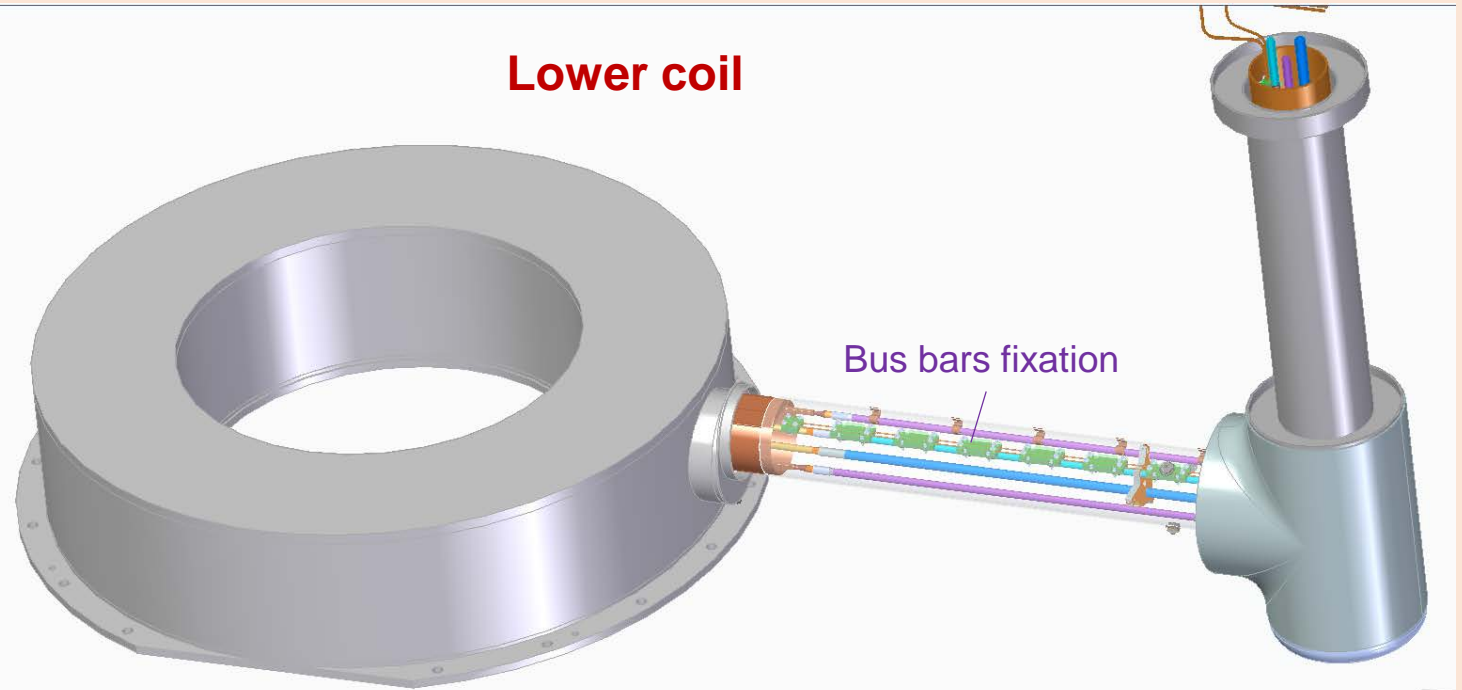
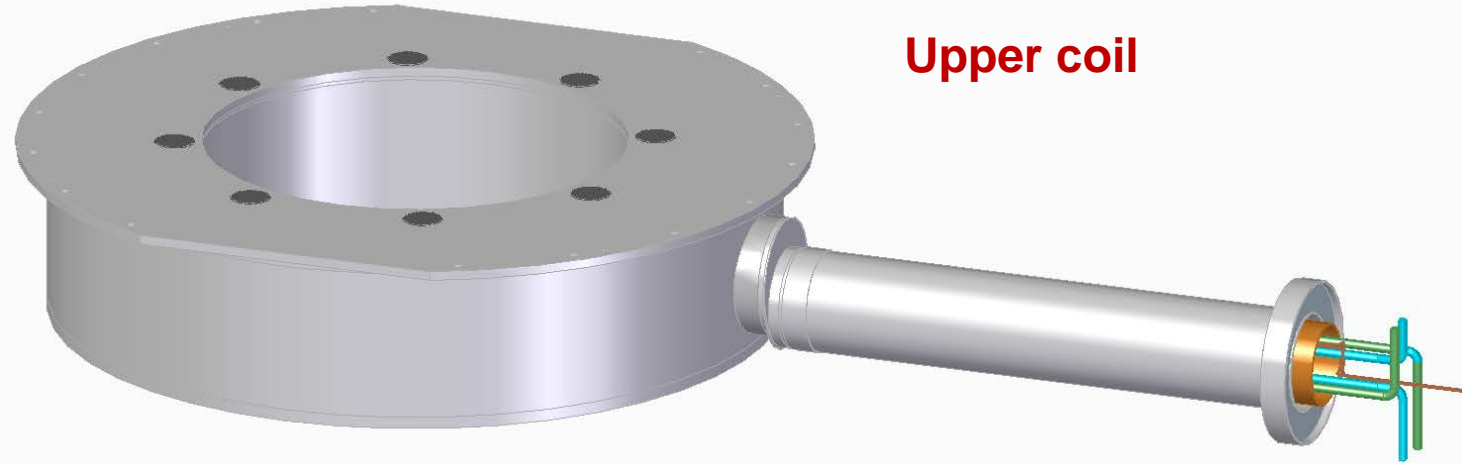

# View of the cryostat

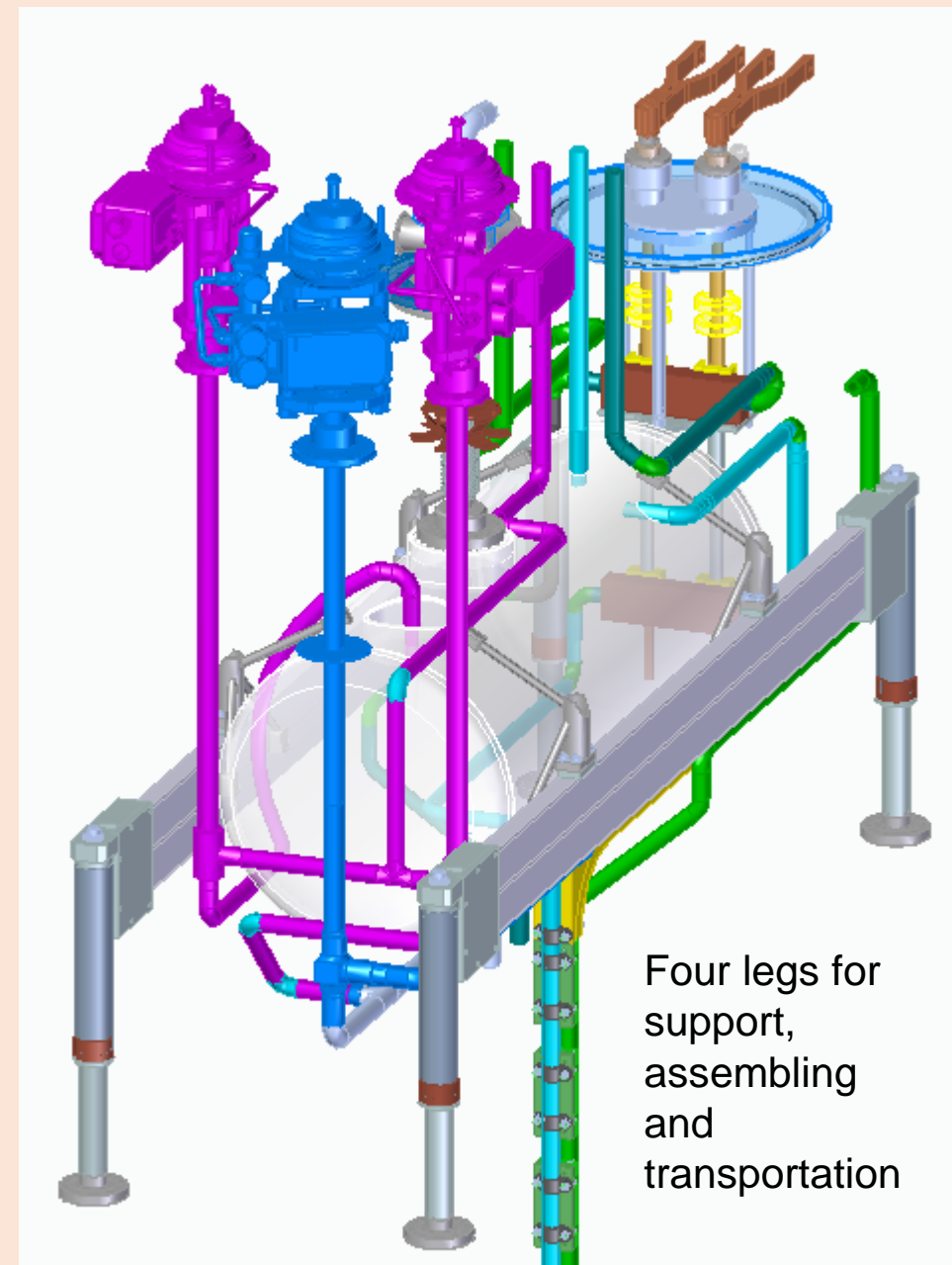
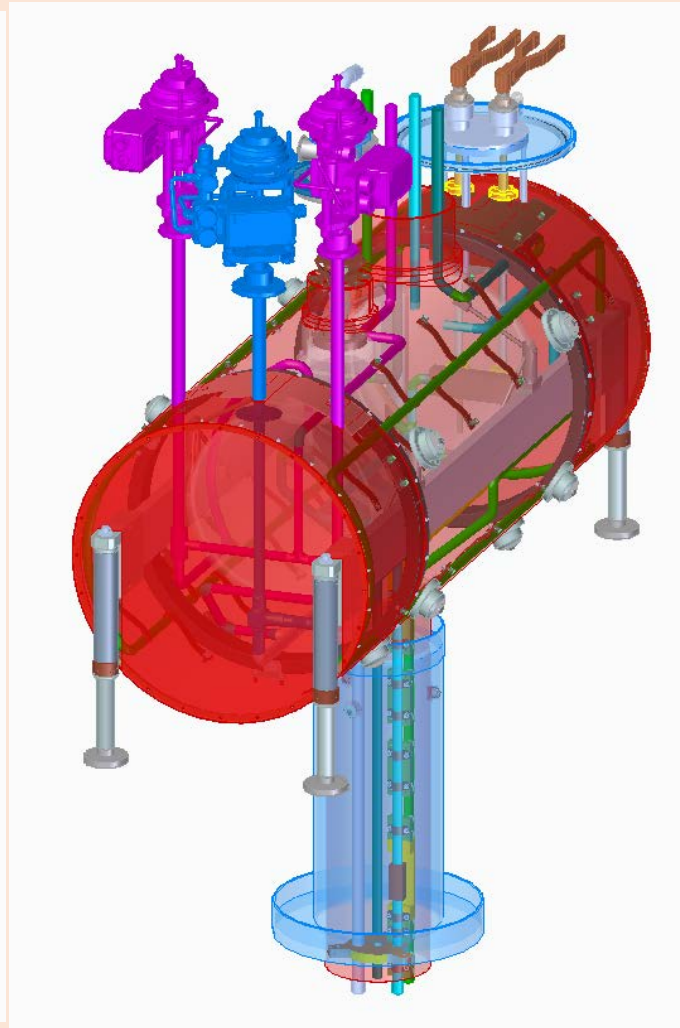
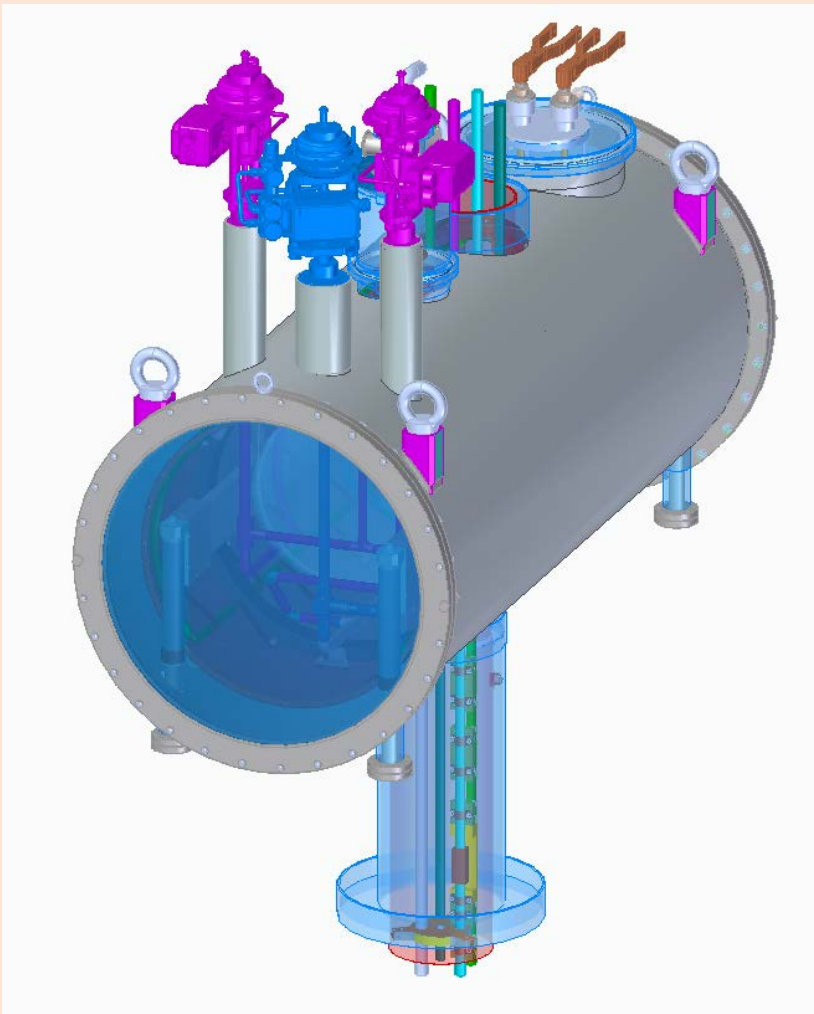

The piping in the cryostat was calculated to withstand 28 bar pressure, cold temperature deformations, for convenience of assembling, and possibility of the transportation. Horizontal displacements of the valves is  $< 1$  mm.



# View of the cryostat 2

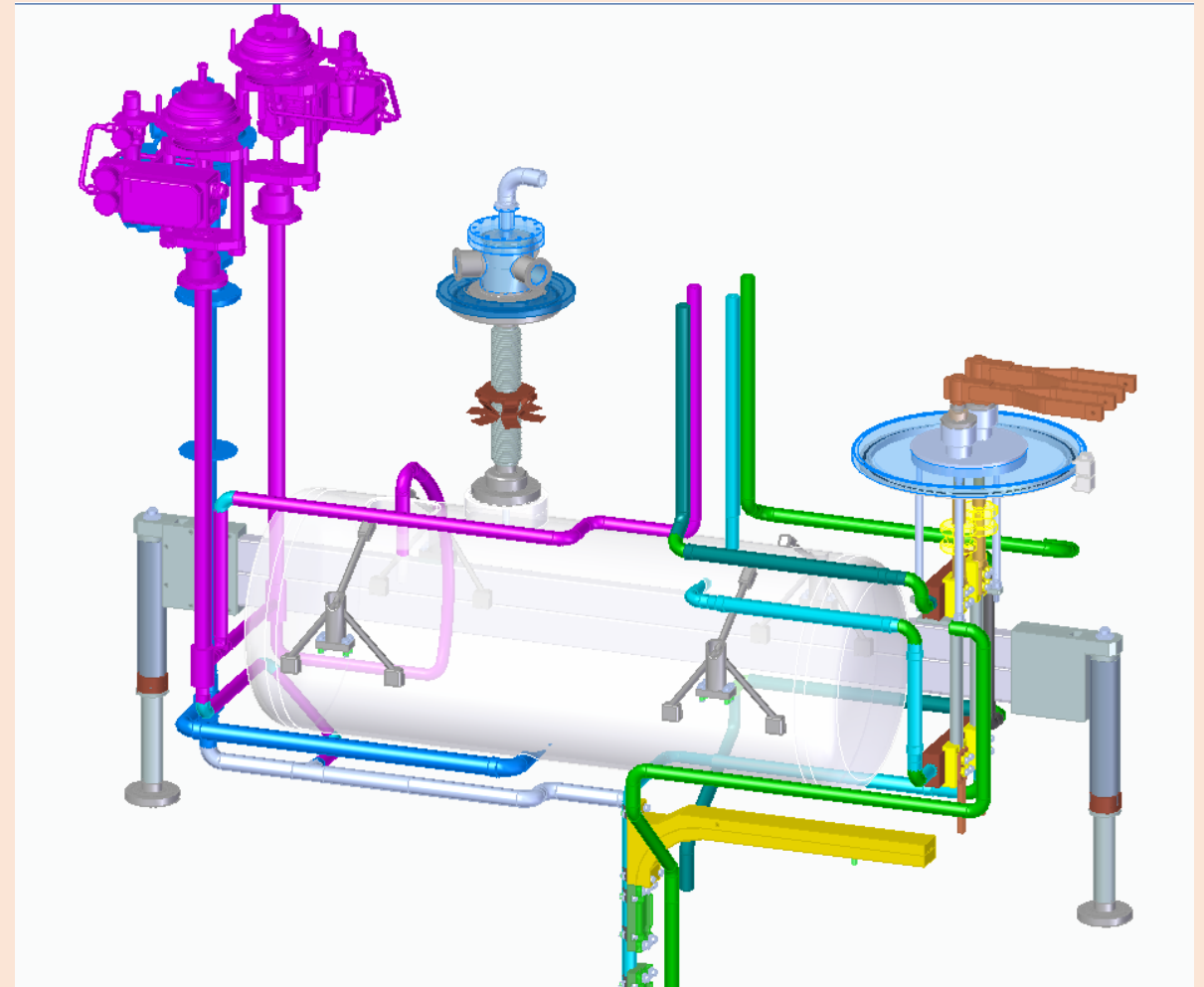
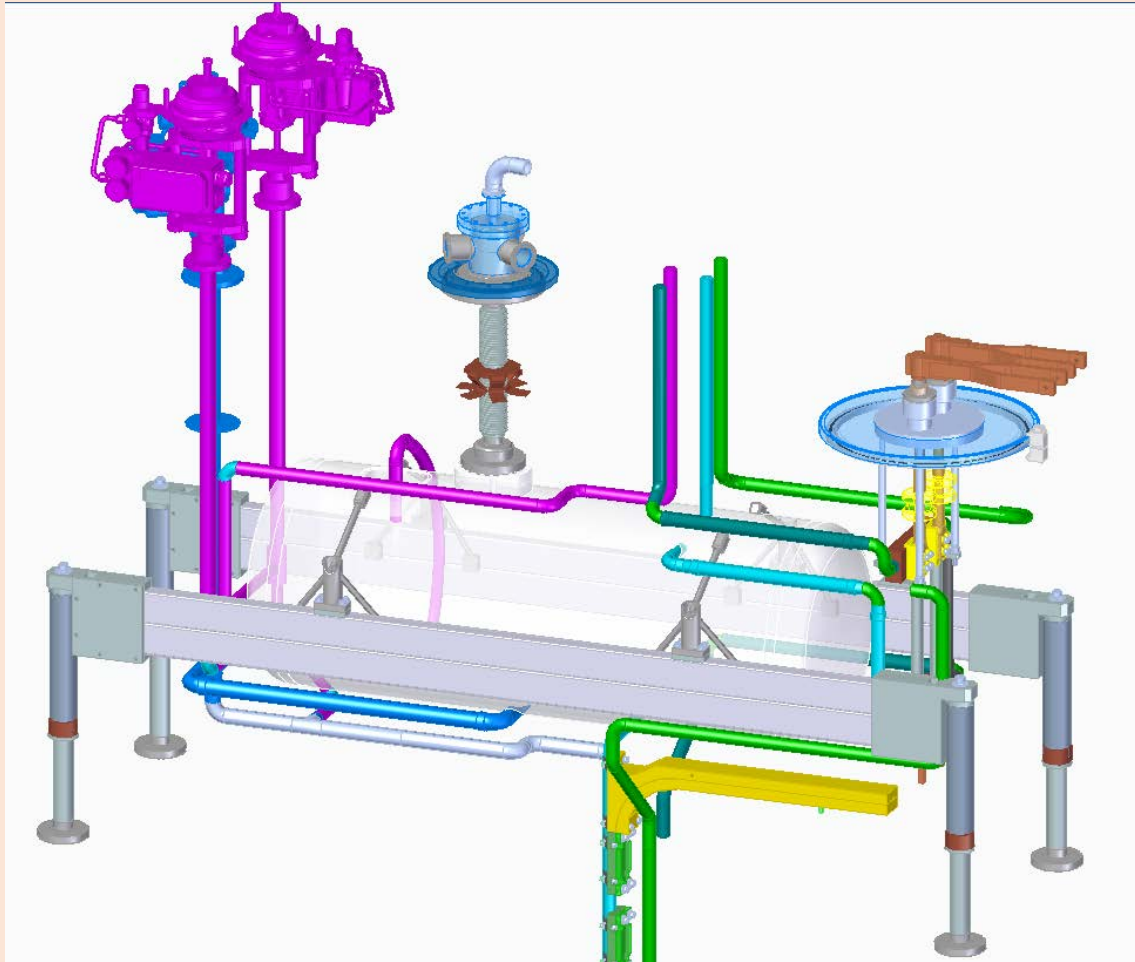

Helium vessel of 180 l of volume

# View of the cryostat 3 – top view

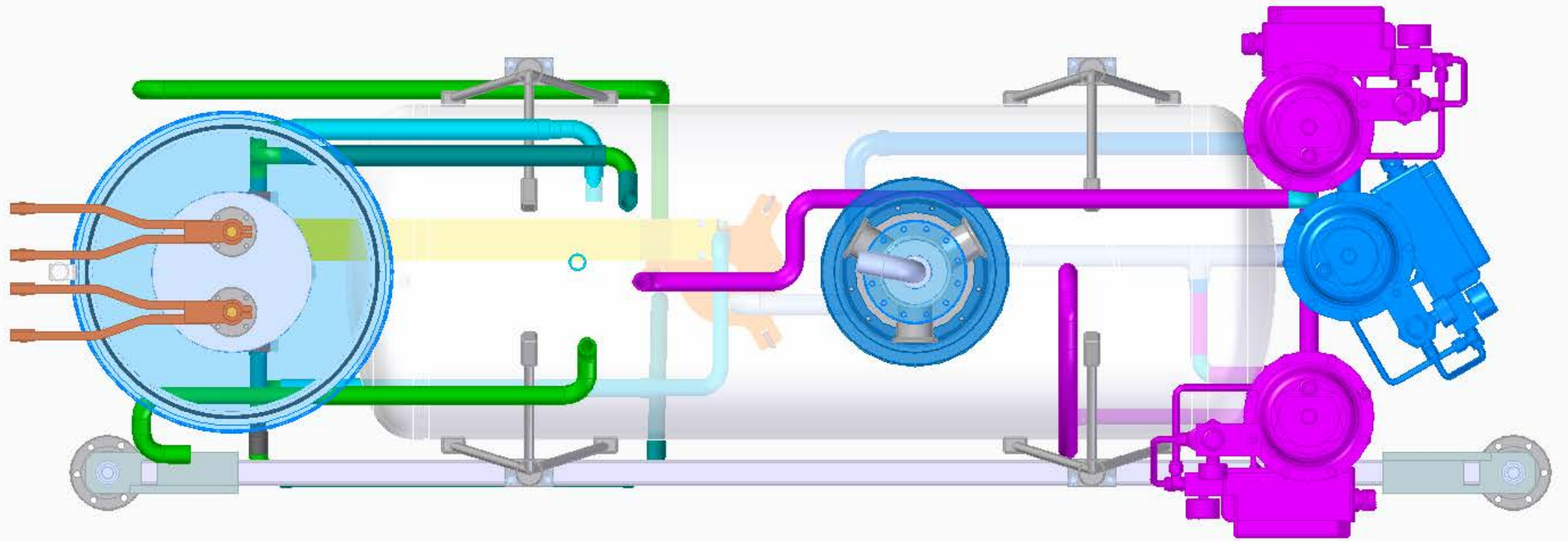

# View of the cryostat 4

Bus bars fixation to the helium tubes and to the current leads.

The heater was designed to give 5 W.

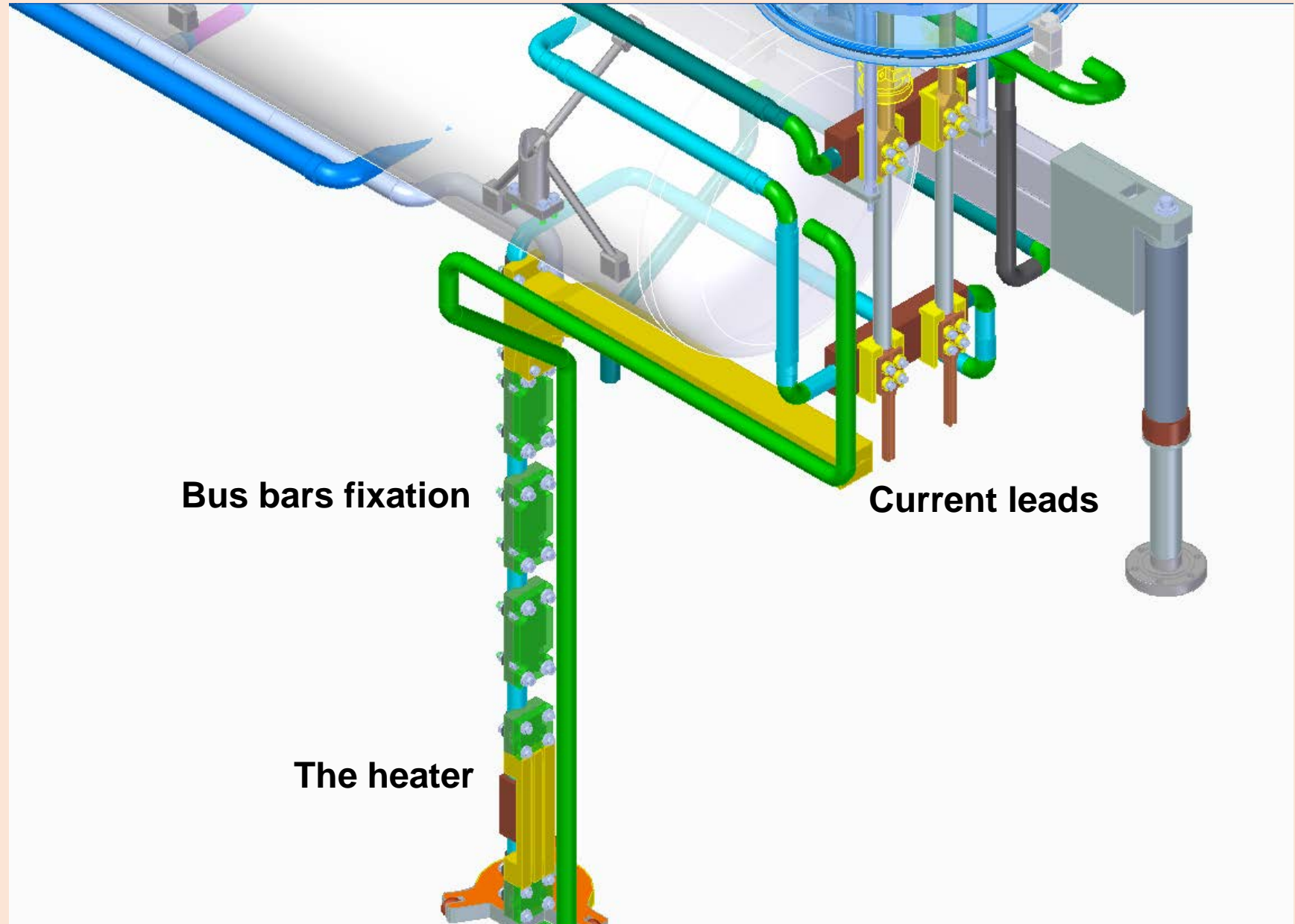





# Bus bars fixation

Copper plates will be used for the bus bar fixation to the helium tubes.

May be not all plates will be made of copper, some quantity of G-10?

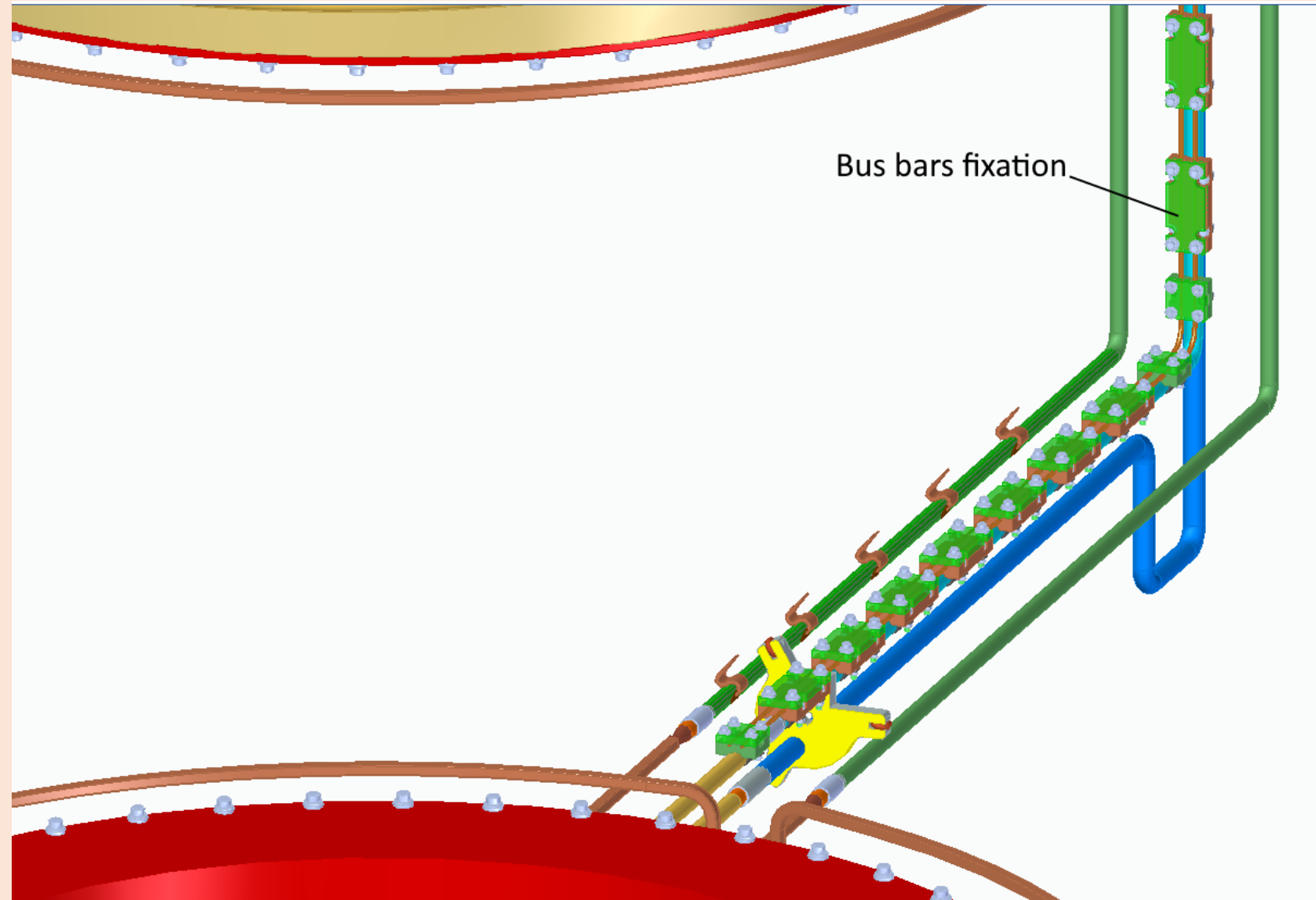

# Current leads

The current leads will be manufactured by SyperOx on the base of HTS tapes.

HTS protection was be calculated.

Heat exchanger was also calculated.

Thermal contact is via sapphire plates.

HTS terminals will be adopted to the sizes of the CBM cable.

Temperatures will be controlled.

**In BINP tests the cryostat will be modified to install a cryocooler to keep the current leads at design temperatures.**

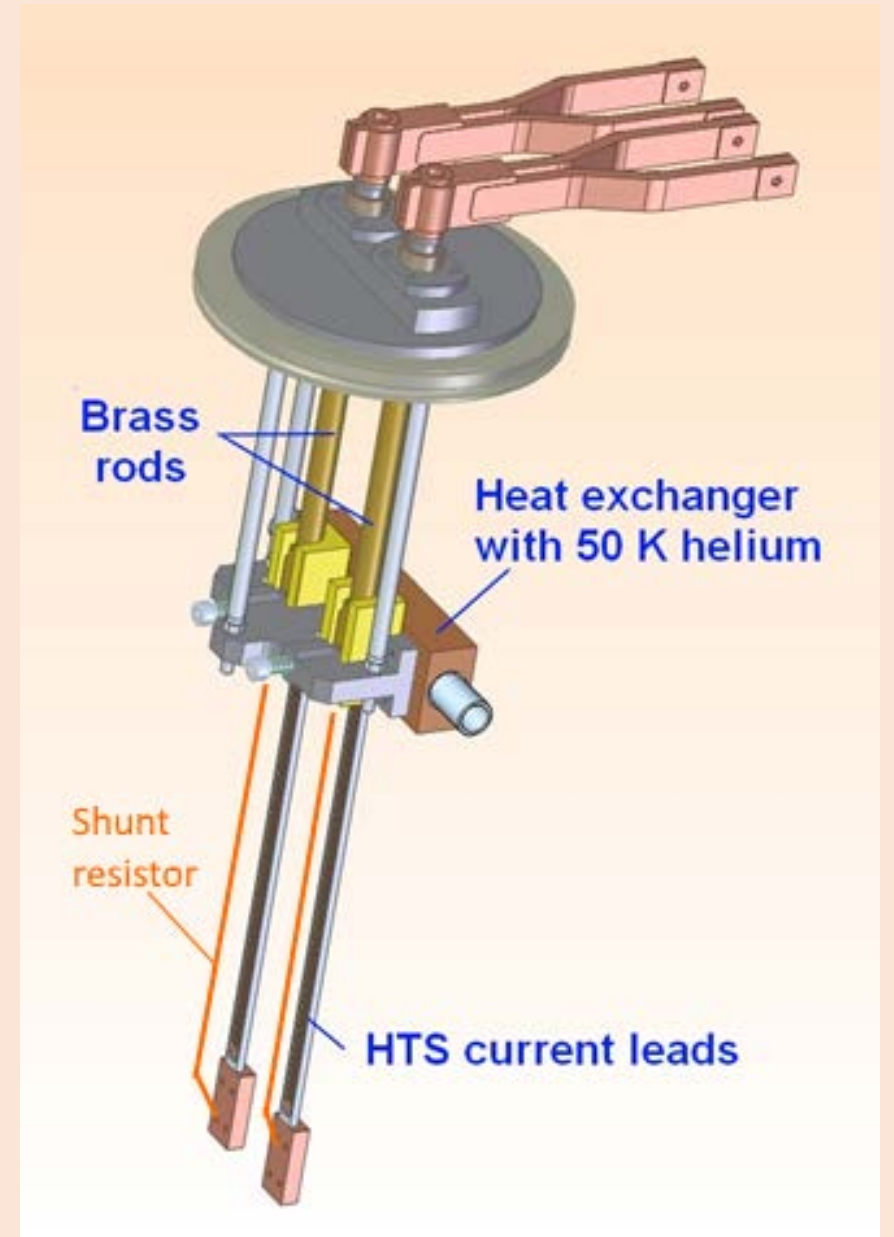

# Cryostat piping calculation

The pipe around the cryostat and the LHe vessel were calculated to withstand 28 bars pressure, stress and strain in the pipes.

The control valves cold parts should not have the horizontal displacement more than 1 mm.

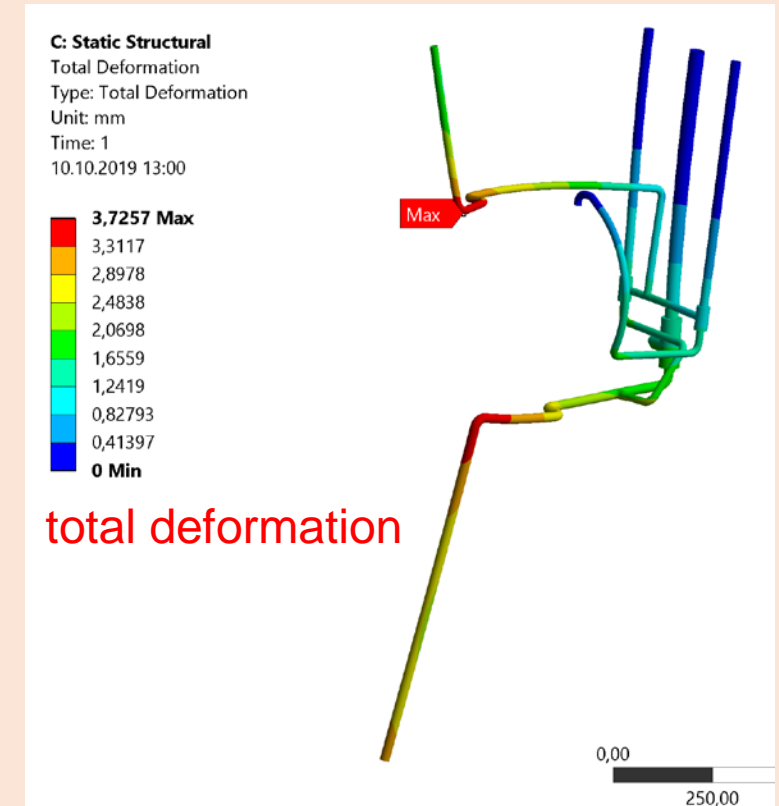
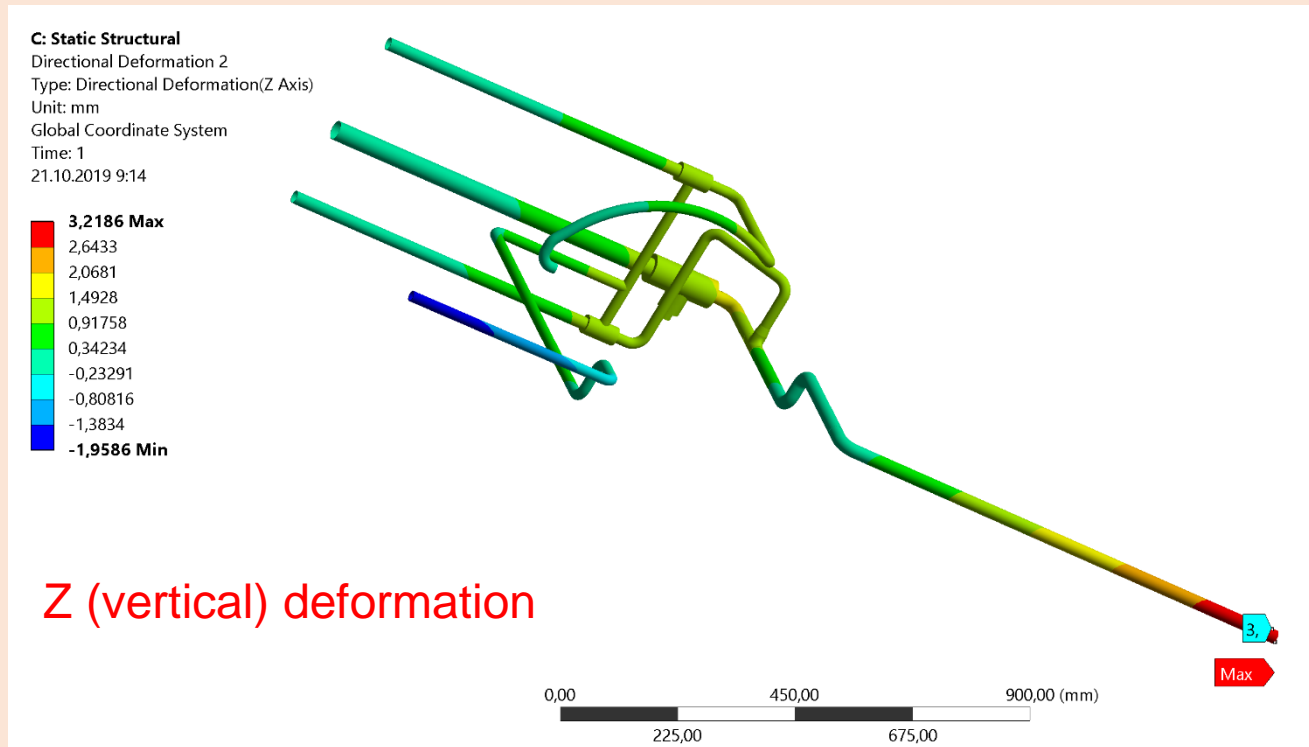
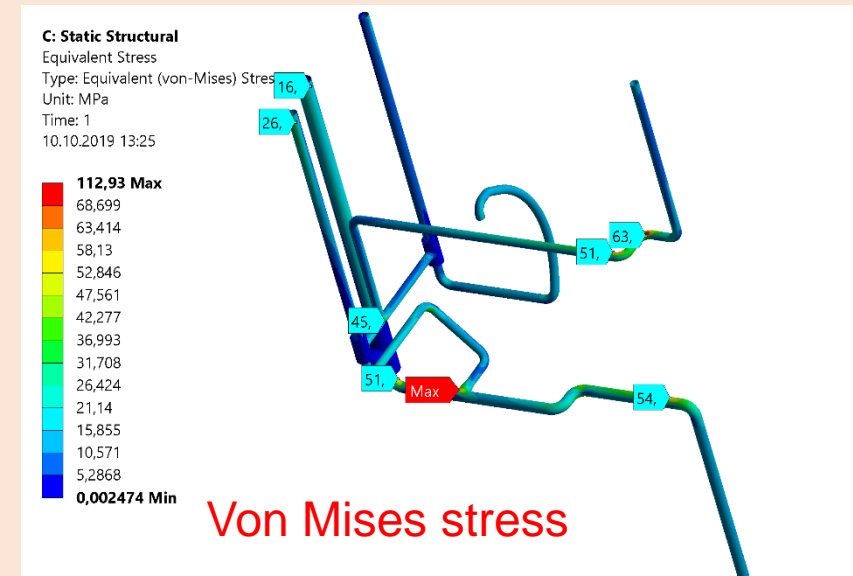
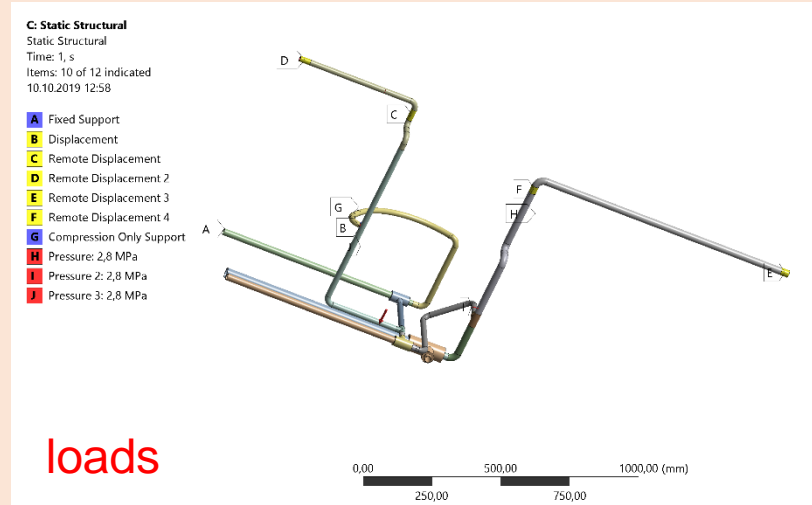

# Heat loads on the cryostat with coils at 4.5 K

Table 9. Heat loads on 4.5 K helium from both coils and the cryostat.

<b>Heat load sources</b>	<b>Values</b>
Thermal radiation on the outer surface of the coil, W	0.12
Support struts, W	< 8.2 expected
Tie rods, W	1.5
Soldering connection of the cable (at least 6 short splices), W	0.12
Thermal radiation on the cryostat, W	0.015
Cryostat suspension, W	<0.1
Current leads, W	0.5
Measurements wires, W	<0.1
Heat bridges of the cryostat neck and others connections, W	<0.1
<i>Eddy currents during the powering for 4 hours, W</i>	2.2
<b><i>Total, W</i></b>	<b><i>~ 10.8 (+2.2)</i></b>

Table 11 Heat loads on 4.6 K helium from the Branch Box, the Feed Box and the transfer line

<b>Heat load from</b>	<b>Values</b>
Thermal radiation on 4.5 K surfaces from the shields on the FB and BB, W	0.15
Supports and suspensions, W	< 2
Control Valves, W	15.2
Check Valves, W	0.9
Measurement wires, W	< 0.01
Heat bridges of the cryostat neck and others connections, W	< 1
<b><i>Total, W</i></b>	<b>19.26</b>



# Heat loads on the cryostat with coils at $\sim 55$ K

Table 10 Heat loads on 50 K helium from both coils and the cryostat

<b>Heat load from</b>	<b>Values</b>
Thermal radiation on the shields from the vacuum vessel, W	10
Support struts, W	90
Tie rods, W	22
Thermal radiation on the cryostat shield, W	1.5
Cryostat suspension, W	2
Current leads, W	120*
Measurements wires, W	0.5
Heat bridges of the cryostat neck and others connections, W	1
<b>Total, W</b>	<b><math>\sim 247</math></b>

\*) It will be corrected after detailed design of the current leads

Table 12 Heat loads on the 60 K helium (return line) from the Branch Box, the Feed Box and the transfer line

<b>Heat load from</b>	<b>Values</b>
Thermal radiation on the shields from the vacuum vessel, W	7
Support and suspensions, W	20
Control valves, W	38
Check valves, W	11
Measurement wires, W	$< 1$
Heat bridges of the cryostat neck and others connections, W	5
<b>Total, W</b>	<b>82</b>

# Thermosyphon circulation

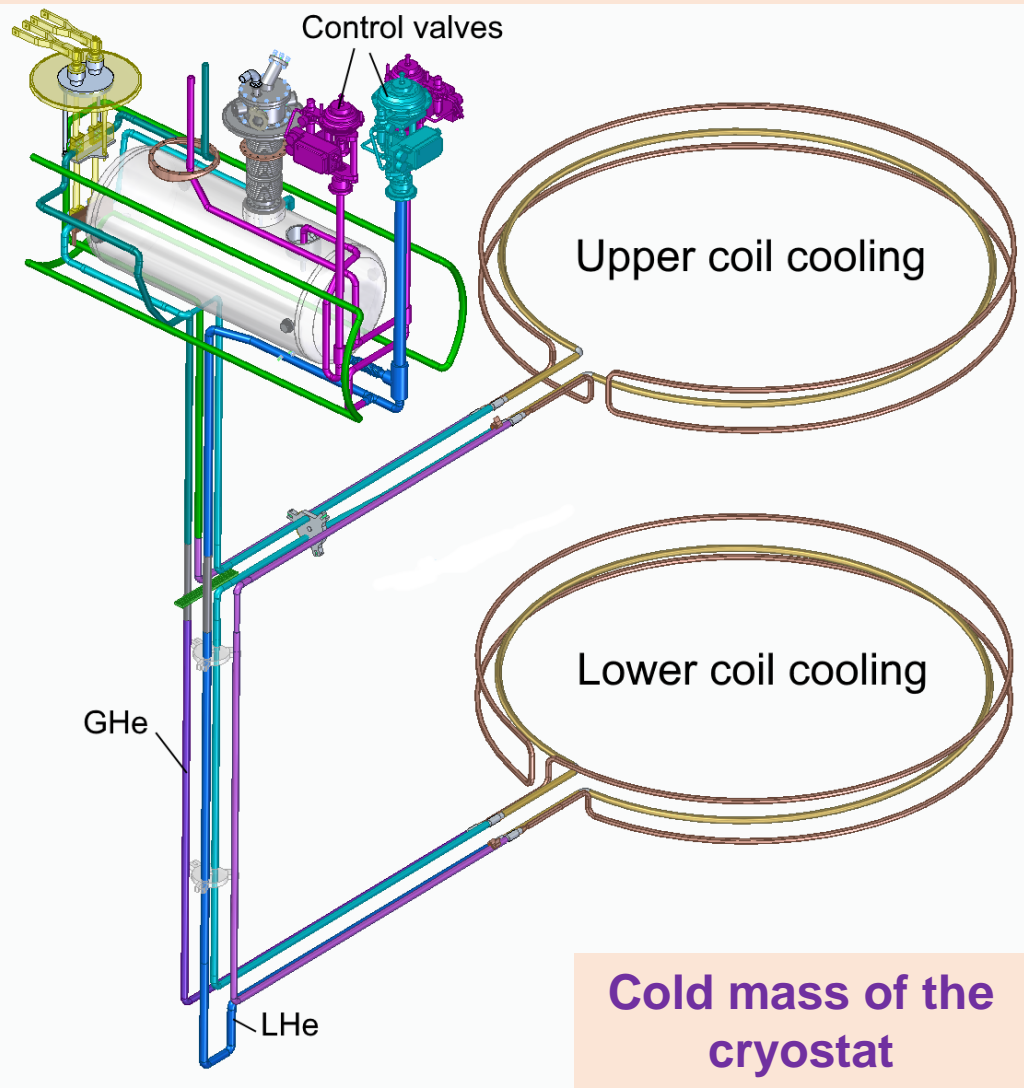

Cold mass of the cryostat

The coils are connected in serial by tubes with liquid helium. The helium flow is pushed by density difference between the vertical channels of the helium flow loop. This is a thermosyphon cooling method. The peculiarity of this design is that the coils are serially connected. The horizontal part of the loop is relatively large, about 14 m. **The thermosyphon cooling estimations show that the vapor quality (x) at the outlet of the cooling loop is less than 0.1 that is quite low.** The stable thermosyphon flow works with x up to 0.8 value.

The horizontal tubes inclination and a 5 W heater are foreseen for stabilization of the He flow.

**The direct cooling by 4.6 K helium from the cryoplant is possible.**

$$\Delta p = \rho_L g h_1 - \rho_{m2} g h_2 - \rho_{m3} g h_3 - \phi_{Io} \cdot \xi \frac{8G^2}{\pi^2 \rho_m} \cdot \frac{L_{12}}{d^5} - \dots - \phi_{Io} \cdot \xi \frac{8G^2}{\pi^2 \rho_m} \cdot \frac{L_{89}}{d^5} = 0$$

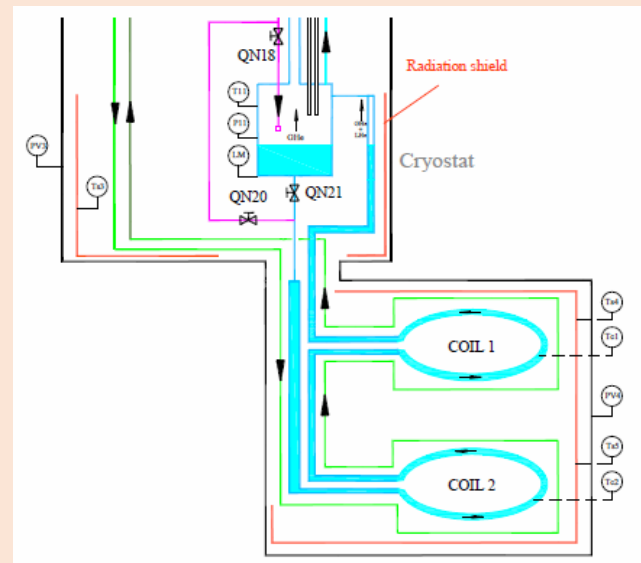

The estimations were also done by Marion Kauschke, GSI and By Jean-Pierre LOTTIN of Saclay. Both results are  $x < 0.1$

*After increasing the total length of the thermosyphon tubes by a factor of 10 (that corresponds increasing the heat power by a factor of 3.2) the results of solving the equation will be:  $\chi = 0.167$  and  $\Delta p = 750 \text{ Pa}$  (7.4 mbar). These mean that the results of the calculations will be changed not principally if uncertainty of the given parameters is 10-20%.*

# Heat transfer estimations

The heat transfer estimations are based on pool boiling of helium in “large volumes”.

The “large volume” is treated as volume with dimensions much higher than bubble diameters which are 0.08-0.16 mm.

The cooling tube of the coils has the diameter of 16 mm.

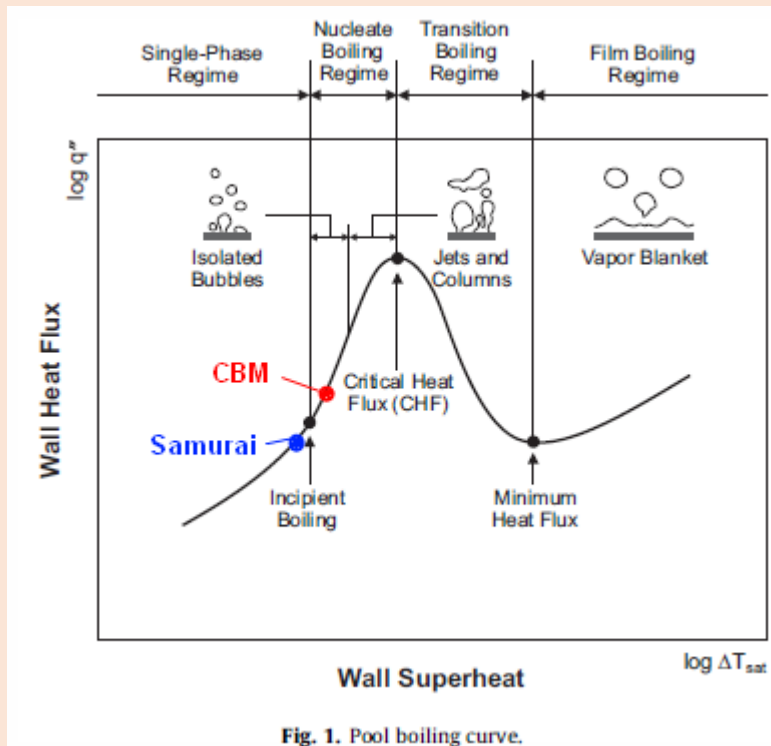
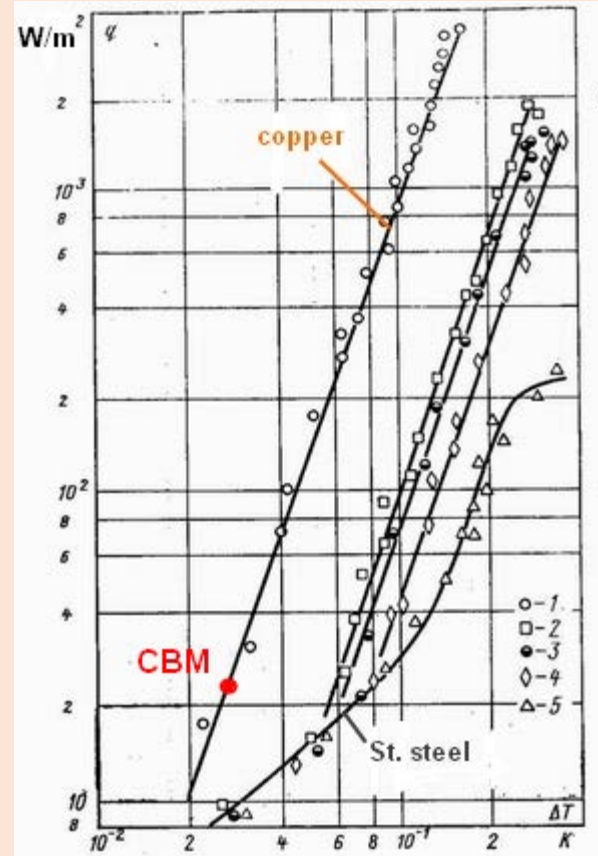
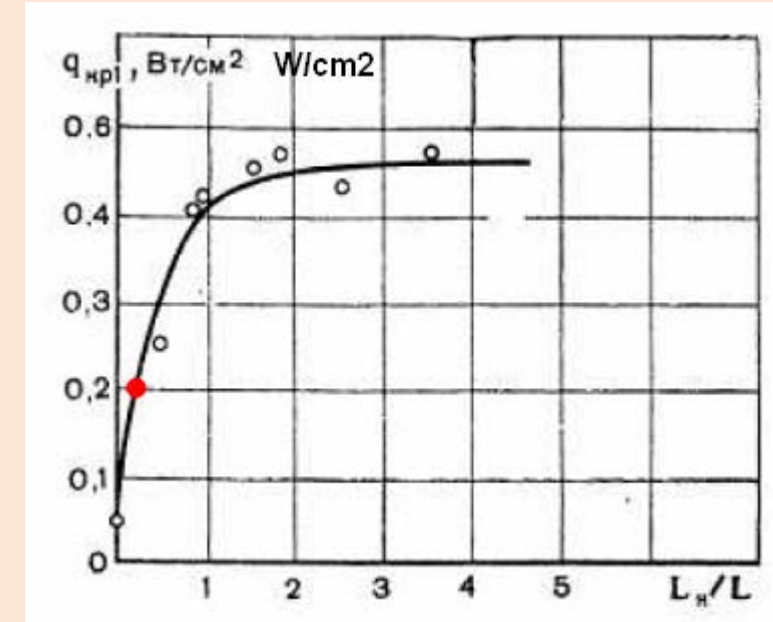

Fig. 1. Pool boiling curve.



The working point for the CBM magnet is close to single phase heat transfer. The critical heat flux is by 100 times higher.



Experimental data for critical heat flux on heated horizontal channel ( $L$ ) and unheated vertical channel ( $L_H$ ). The red point marks the length ratio for the CBM magnet.

# New Branch Box

**The mass is 3500 kg**  
**Diameter is 1500 mm**  
**Length is 2500 mm**

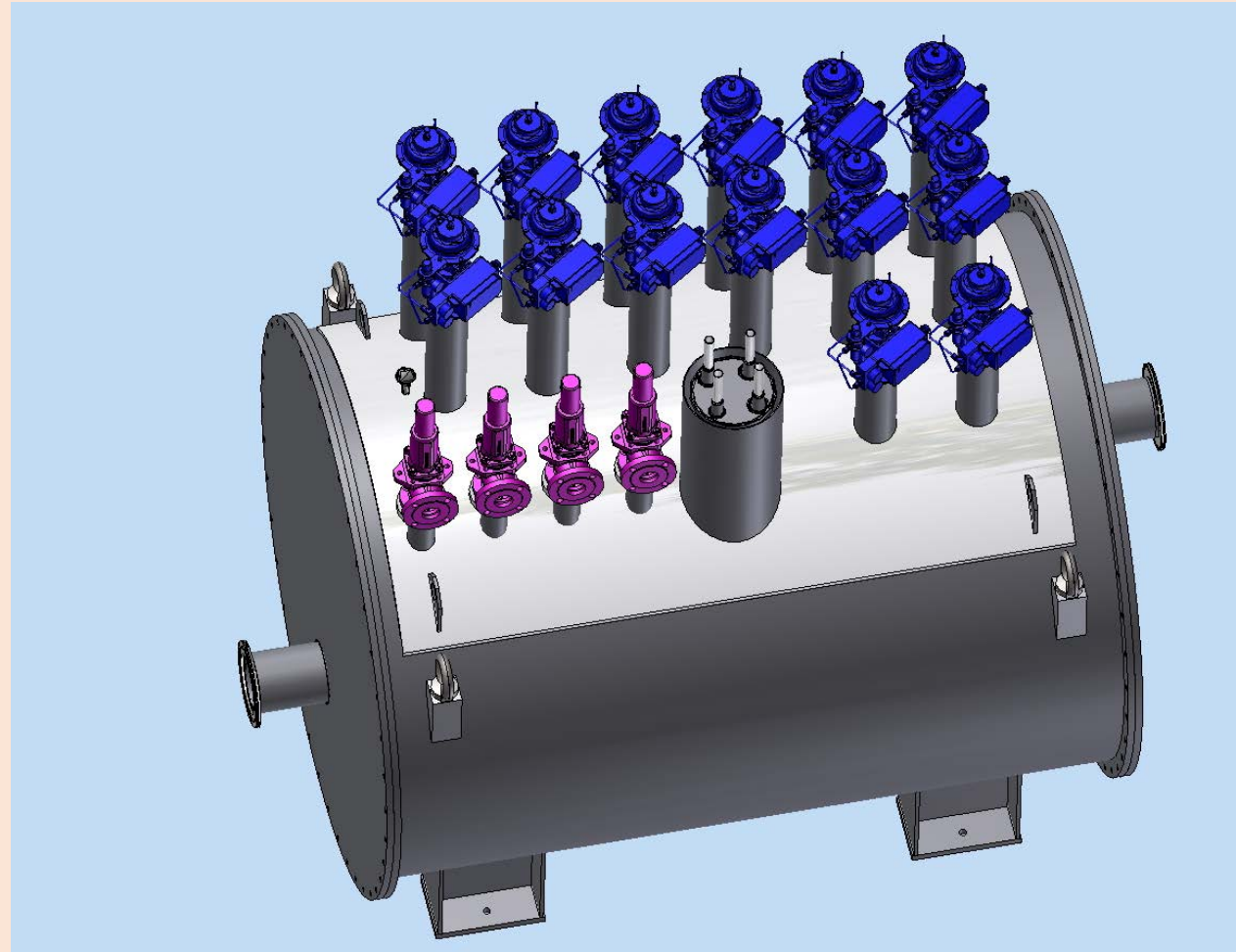



# Conclusions

- The preliminary design of the cryostat is presented.
- The heat loads are estimated.
- The cryostat calculations were done.
- The design of the HTS current leads is discussed in the quench calculations.
- The thermosyphon evaluations are presented